

Original instructions

AR3200C

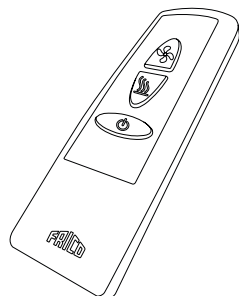
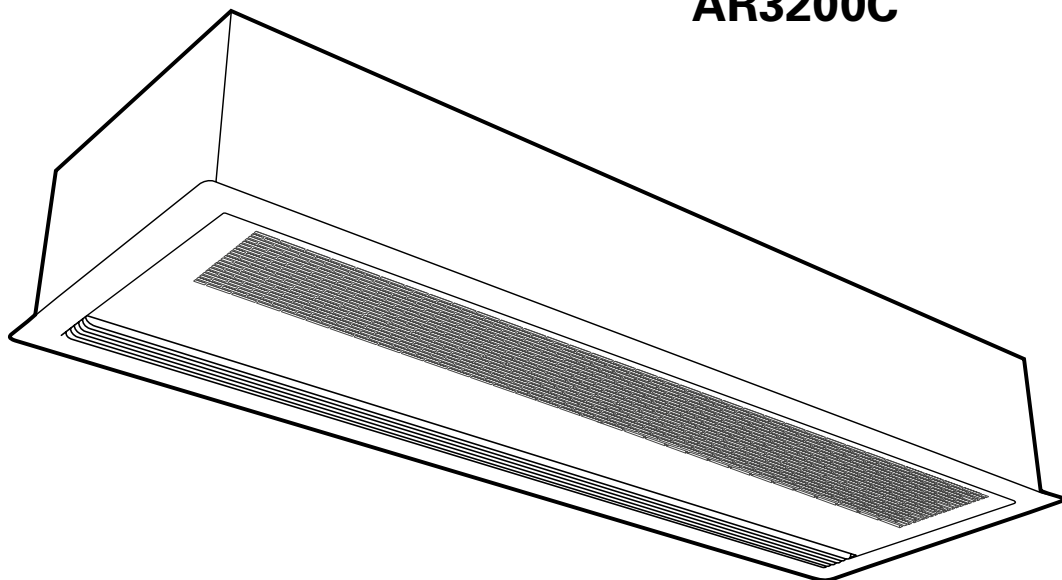

SE 19

EN ... 26

FR ... 33

NO ... 41

DE ... 48

ES ... 56

IT ... 64

NL ... 72

PL ... 80

RU ... 88

- SE** Introduktionssidorna består huvudsakligen av bilder. För översättning av de engelska texter som används, se respektive språksidor.
- EN** The introduction pages consist mainly of pictures. For translation of the English texts used, see the respective language pages.
- FR** Les pages de présentation contiennent principalement des images. Pour la traduction des textes en anglais, consultez la page correspondante à la langue souhaitée.
- NO** Introduksjonssidene består hovedsakelig av bilder. For oversettelse av de engelske tekstene, se de respektive språksidene
- DE** Die Einleitungsseiten bestehen hauptsächlich aus Bildern. Für die Übersetzung der verwendeten Texte in englischer Sprache, siehe die entsprechenden Sprachseiten.
- ES** Las páginas introductorias contienen básicamente imágenes. Consulte la traducción de los textos en inglés que las acompañan en las páginas del idioma correspondiente.
- NL** De inleidende pagina's bevatten hoofdzakelijk afbeeldingen. Voor een vertaling van de gebruikte Engelse teksten, zie de pagina's van de resp. taal.
- IT** Le pagine introduttive contengono prevalentemente immagini. Per le traduzioni dei testi scritti in inglese, vedere le pagine nelle diverse lingue.
- PL** Początkowe strony zawierają głównie rysunki. Tłumaczenie wykorzystanych tekstów angielskich znajduje się na odpowiednich stronach językowych.
- RU** Страницы в начале Инструкции состоят в основном из рисунков, схем и таблиц. Перевод встречающегося там текста приведен в разделе RU.

AR3200C

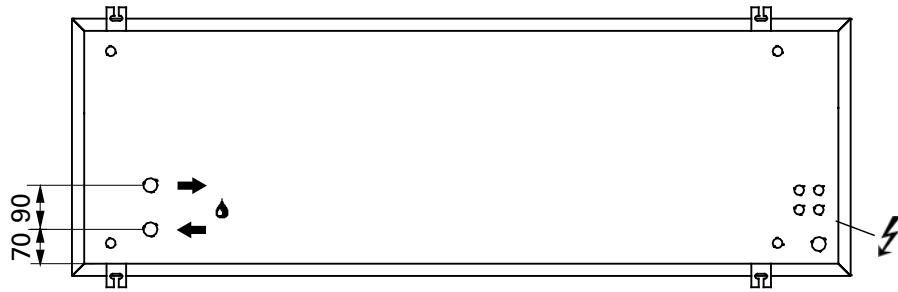
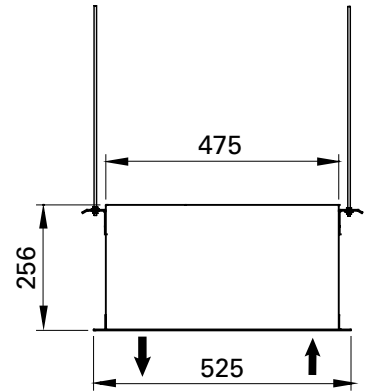
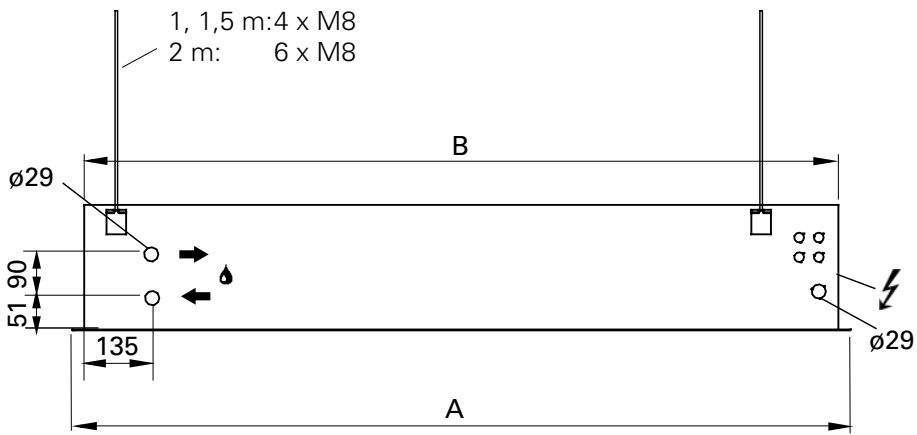

	A	B
	[mm]	[mm]
AR3210C	1078	1028
AR3215C	1588	1538
AR3220C	2078	2028

Mounting on threaded bars outside the unit

Front view

AR3210C / AR3215C

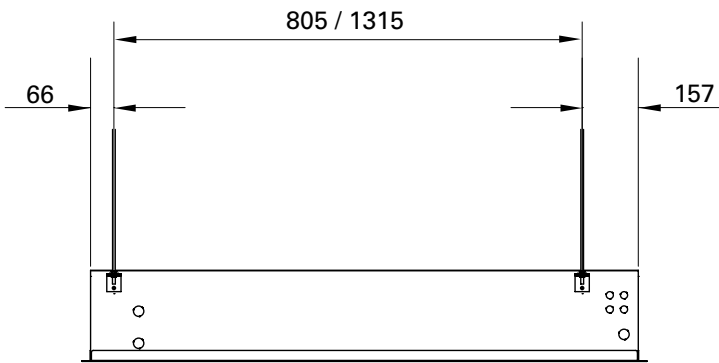

Side view

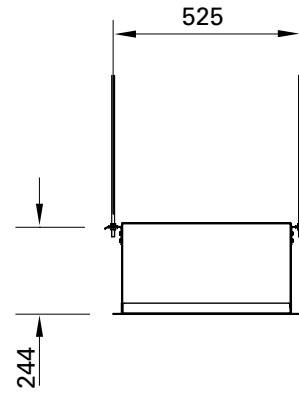

AR3220C

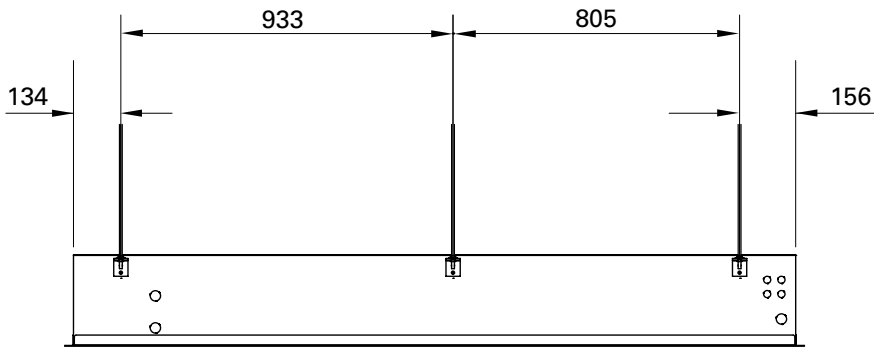

Mounting on threaded bars outside the unit

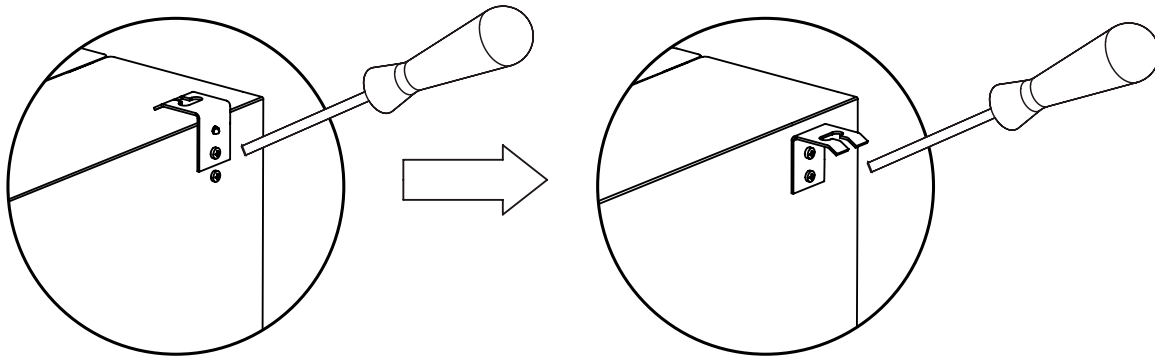

Fig. 1a: Mounting brackets on delivery.

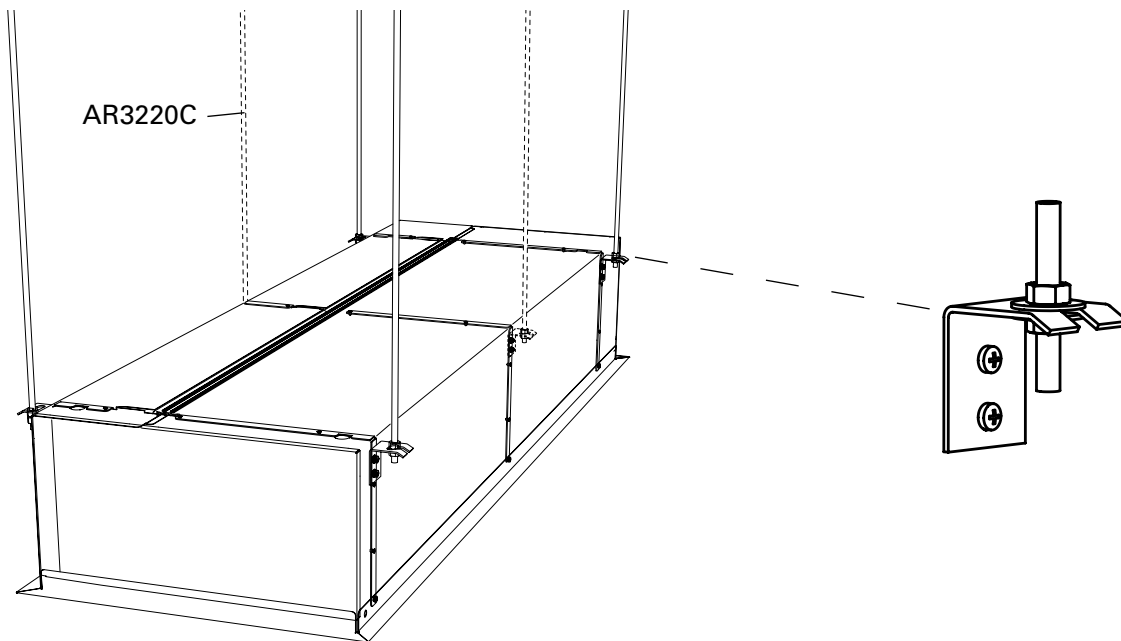
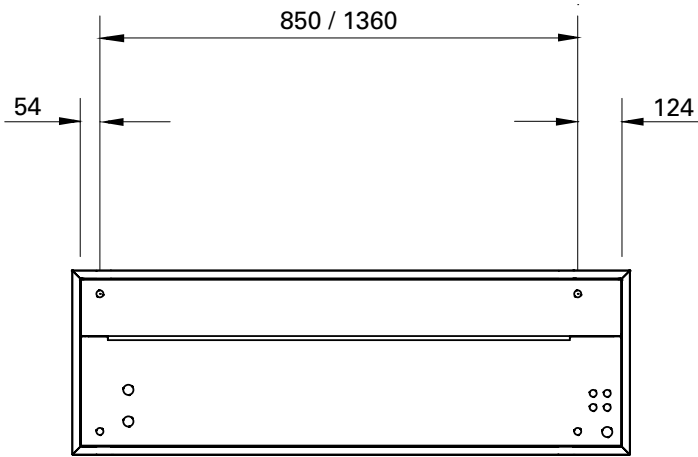

Fig. 1b. Mounting on threaded bars outside the unit.

Mounting on threaded bars inside the unit

Top view

AR3210C / AR3215C



Side view

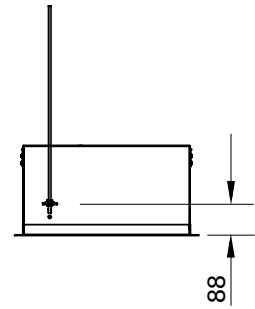

AR3220C

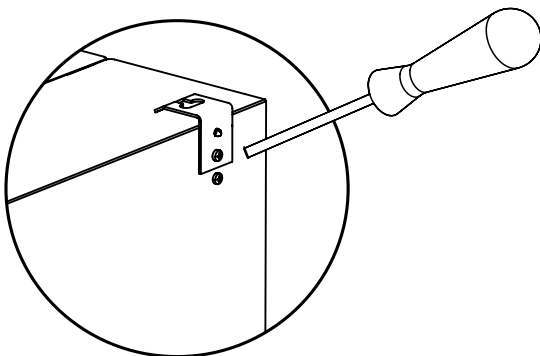
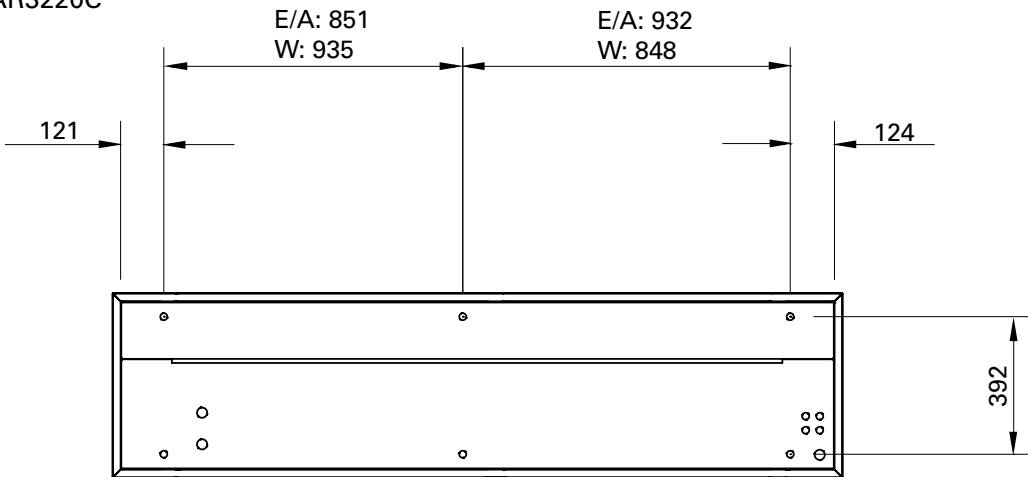

Fig. 2a: Mounting brackets on delivery.

Mounting on threaded bars inside the unit

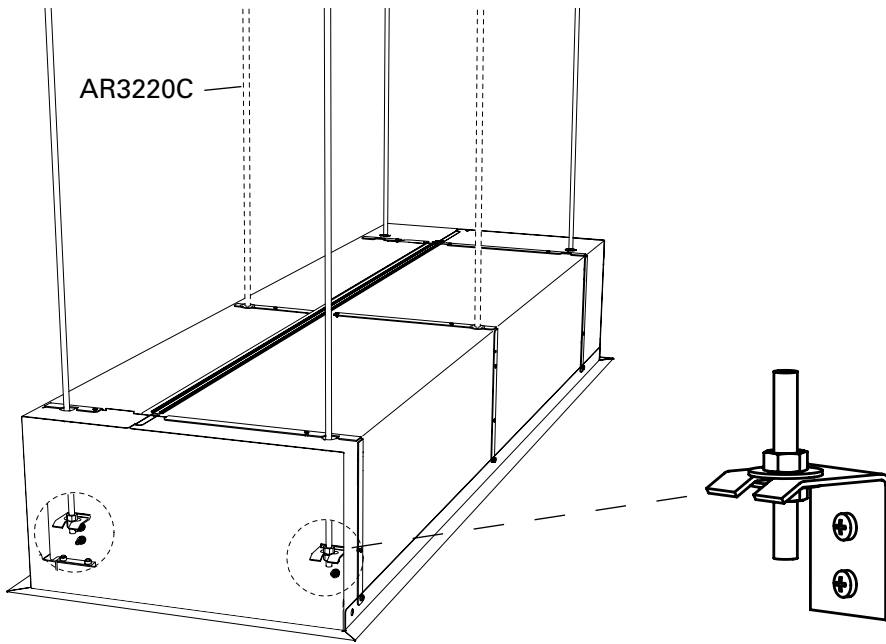

Fig. 2b. Mounting on threaded bars inside the unit.

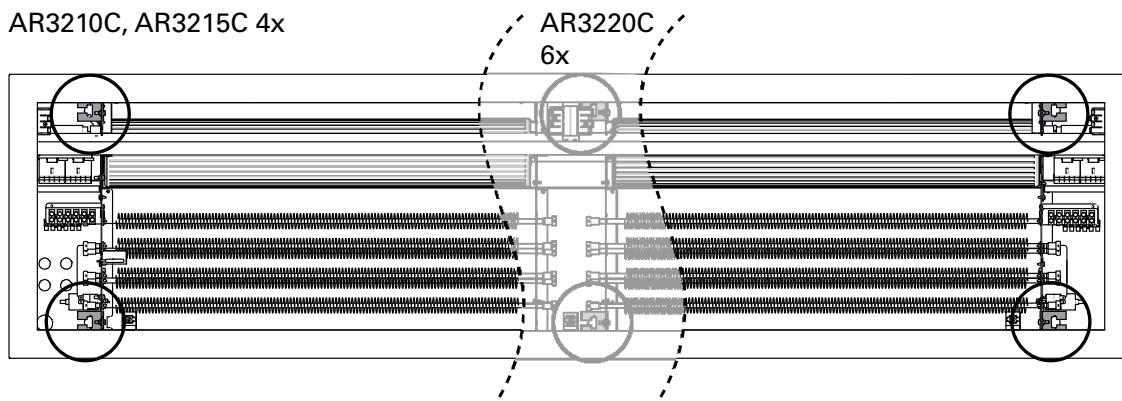

Fig. 2c. Location of the mounting brackets on the inside of the unit.

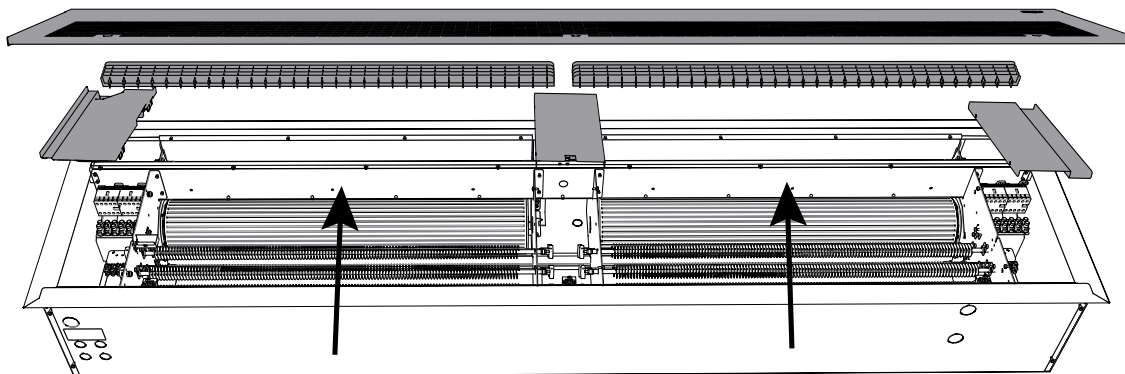

Fig. 2d. In order to mount the brackets, remove the service hatch, outlet grille and covering plates.

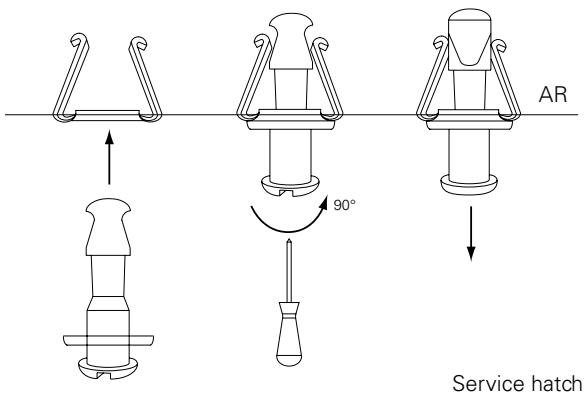

Fig. 3a: Snap fixings

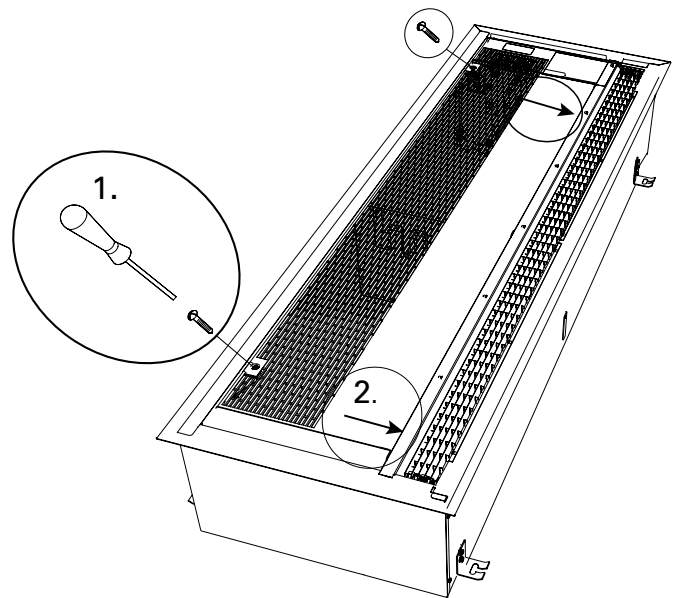

Fig. 3b: Open the unit.

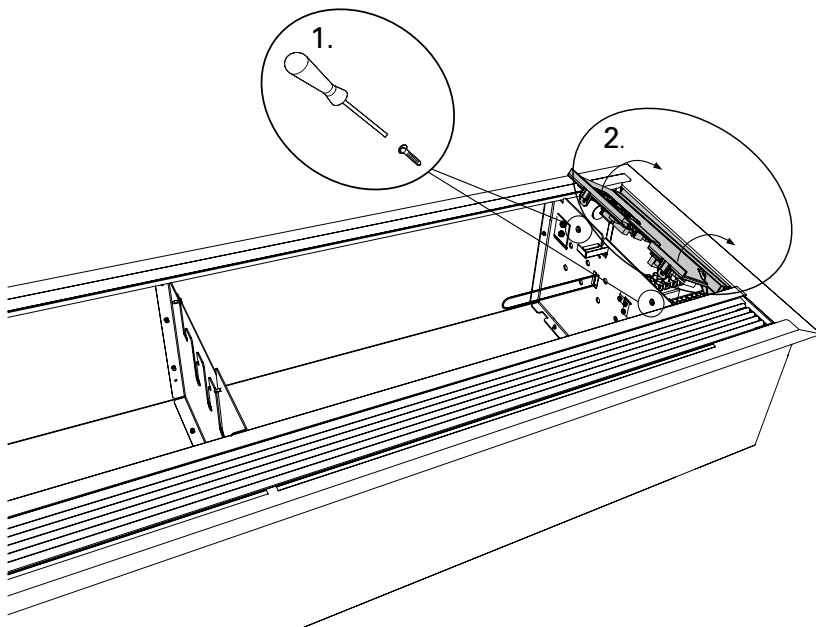
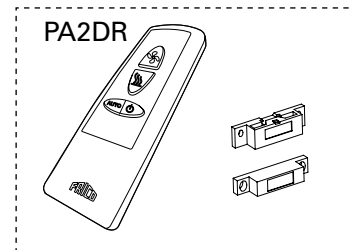
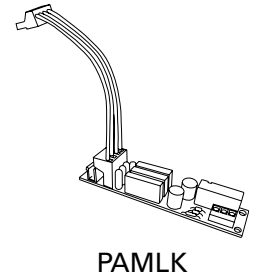
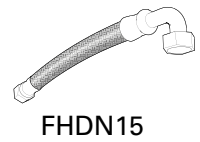
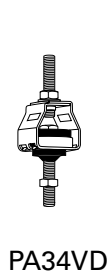
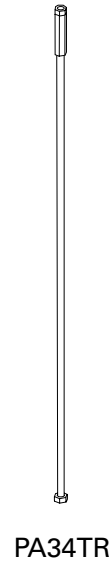

Fig. 4: Terminal box and control panel inside unit.

AR3200C

Accessories

PA34TR15	AR3210C, AR3215C, 1 m
PA34TR20	AR3220C, 1 m
PA34CB15	AR3210C, AR3215C
PA34CB20	AR3220C
PA34VD15	AR3210C, AR3215C
PA34VD20	AR3220C
PAMLK	AR3200C
FHDN15	AR3200C W
PA2DR	AR3200C



Type	RSK-nr (SE)	NRF-nr (NO)	Connection
VLSP15LF	670 45 35		DN15
VLSP15NF	670 45 36	850 26 36	DN15
VLSP20	670 45 37	850 26 37	DN20
VLSP25	670 45 38	850 26 38	DN25
VLSP32	670 45 39	850 26 39	DN32
VOT15	673 61 93	85 024 05	DN15
VOT20	673 61 94	85 024 06	DN20
VOT25	673 61 95	85 024 07	DN25

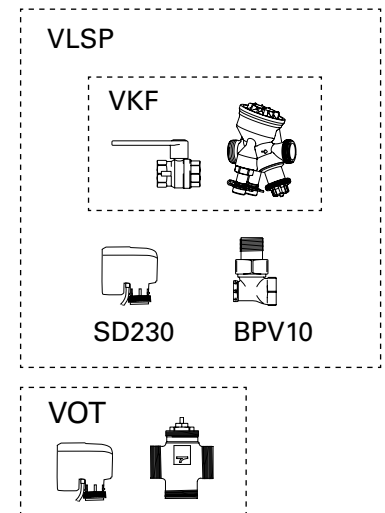

Technical specifications

✱ Ambient, no heat - AR3200C A

Type	Output [kW]	Airflow* ¹ [m ³ /h]	Sound power* ² [dB(A)]	Sound pressure* ³ [dB(A)]	Voltage motor [V]	Amperage motor [A]	Length [mm]	Weight [kg]
AR3210CA	0	1000/1800	73	43/57	230V~	0,7	1078	29
AR3215CA	0	1600/2900	73	43/57	230V~	1,3	1588	40
AR3220CA	0	2100/3900	76	44/60	230V~	1,6	2078	55

⚡ Electrical heat - AR3200C E

Type	Output steps [kW]	Airflow* ¹ [m ³ /h]	Δt * ⁴ [°C]	Sound power* ² [dB(A)]	Sound pressure* ³ [dB(A)]	Voltage motor [V]	Amperage motor [A]	Voltage[V] Amperage [A] (heat)	Length [mm]	Weight [kg]
AR3210CE03	2/3	1000/1800	9/5	73	43/57	230V~	0,7	230V~/13	1078	30
AR3210CE05	3,3/5	1000/1800	15/8	73	43/57	230V~	0,7	230V~/21,7 400V3N~/7,2	1078	30
AR3210CE08	5/8	1000/1800	24/13	73	43/57	230V~	0,7	400V3N~/11,6	1078	31
AR3215CE08	4/8	1600/2900	15/8	73	43/57	230V~	1,3	400V3N~/11,6	1588	41
AR3215CE12	8/12	1600/2900	22/12	73	43/57	230V~	1,3	400V3N~/17,3	1588	42
AR3220CE10	5/10	2100/3900	14/8	76	44/60	230V~	1,6	400V3N~/14,5	2078	57
AR3220CE16	10/16	2100/3900	23/12	76	44/60	230V~	1,6	400V3N~/23,1	2078	59

💧 Water heat - AR3200C W

Type	Output* ⁵ [kW]	Airflow* ¹ [m ³ /h]	Δt * ^{4,5} [°C]	Water volume [l]	Sound power* ² [dB(A)]	Sound pressure* ³ [dB(A)]	Voltage motor [A]	Amperage motor [A]	Length [mm]	Weight [kg]
AR3210CW	8,2	1000/1500	19/16	1,1	69	44/53	230V~	0,6	1078	30
AR3215CW	14	1700/2600	19/16	1,7	72	48/56	230V~	1,0	1588	41
AR3220CW	18	2500/3150	18/17	2,3	72	50/56	230V~	1,2	2078	56

*¹) Lowest/highest airflow of totally 3 fan steps.

*²) Sound power (L_{WA}) measurements according to ISO 27327-2: 2014, Installation type E.

*³) Sound pressure (L_{pA}). Conditions: Distance to the unit 5 metres. Directional factor: 2. Equivalent absorption area: 200 m². At lowest/highest airflow.

*⁴) Δt = temperature rise of passing air at maximum heat output and lowest/highest airflow.

*⁵) Applicable at water temperature 60/40 °C, air temperature, in +18 °C.

Protection class A3200C E: IP20.

Protection class A3200C A/W: IP21.

CE compliant.

AR3200C

Output charts

			Supply water temperature:90 °C Room temperature: +18 °C Outlet air temperature: +35 °C*1				Water temperature: 90/70 °C Room temperature: +18 °C			
Type	Fan position	Airflow [m³/h]	Output [kW]	Return water temp. [°C]	Water flow [l/s]	Pressure drop [kPa]	Output *2 [kW]	Outlet air temp. [°C]	Water flow [l/s]	Pressure drop [kPa]
AR3210CW	max	1500	8,8	32	0,04	1,5	17,0	52	0,21	32,8
	min	1000	5,9	28	0,02	0,6	13,1	57	0,16	20,4
AR3215CW	max	2600	15,2	30	0,06	5,4	29,4	51	0,36	126,0
	min	1700	10,0	25	0,04	2,1	22,4	57	0,27	76,9
AR3220CW	max	3150	18,2	29	0,07	3,1	36,7	52	0,45	83,6
	min	2500	14,3	27	0,06	2,0	31,6	55	0,39	63,8

			Supply water temperature:80 °C Room temperature: +18 °C Outlet air temperature: +35 °C*1				Water temperature: 80/60 °C Room temperature: +18 °C			
Type	Fan position	Airflow [m³/h]	Output [kW]	Return water temp. [°C]	Water flow [l/s]	Pressure drop [kPa]	Output *2 [kW]	Outlet air temp. [°C]	Water flow [l/s]	Pressure drop [kPa]
AR3210CW	max	1500	8,8	35	0,05	2,4	14,1	46	0,17	23,7
	min	1000	5,9	30	0,03	1,0	10,9	50	0,13	14,8
AR3215CW	max	2600	15,2	33	0,08	8,5	24,5	46	0,30	92,3
	min	1700	10,0	28	0,05	3,4	18,6	50	0,23	56,3
AR3220CW	max	3150	18,2	32	0,09	4,9	30,5	47	0,37	60,7
	min	2500	14,3	29	0,07	2,9	26,3	49	0,32	46,4

			Supply water temperature:70 °C Room temperature: +18 °C Outlet air temperature: +35 °C*1				Water temperature: 70/50 °C Room temperature: +18 °C			
Type	Fan position	Airflow [m³/h]	Output [kW]	Return water temp. [°C]	Water flow [l/s]	Pressure drop [kPa]	Output *2 [kW]	Outlet air temp. [°C]	Water flow [l/s]	Pressure drop [kPa]
AR3210CW	max	1500	8,8	38	0,07	4,33	11,1	40	0,14	15,8
	min	1000	5,9	33	0,04	1,66	8,6	43	0,10	10,0
AR3215CW	max	2600	15,2	37	0,11	16,3	19,5	40	0,24	62,4
	min	1700	10,0	31	0,06	5,68	14,9	44	0,18	38,3
AR3220CW	max	3150	18,2	36	0,13	9,48	24,2	41	0,29	40,8
	min	2500	14,3	32	0,09	4,92	21,0	43	0,25	31,3

*1) Recommended outlet air temperature for good comfort and optimized output.

*2) Nominal output at given supply and return water temperature.

AR3200C

Output charts

			Supply water temperature: 60 °C Room temperature: +18 °C Outlet air temperature: +35 °C*1				Water temperature: 60/40 °C Room temperature: +18 °C			
Type	Fan position	Airflow [m³/h]	Output [kW]	Return water temp. [°C]	Water flow [l/s]	Pressure drop [kPa]	Output *2 [kW]	Outlet air temp. [°C]	Water flow [l/s]	Pressure drop [kPa]
AR3210CW	max	1500	8,8	43	0,12	14,0	8,2	34	0,10	9,2
	min	1000	5,9	37	0,06	4,0	6,4	37	0,08	5,9
AR3215CW	max	2600	15,2	42	0,20	48,5	14,4	34	0,17	37,2
	min	1700	10,0	35	0,10	12,5	11,1	37	0,13	23,1
AR3220CW	max	3150	18,2	41	0,23	27,5	17,9	35	0,22	24,1
	min	2500	14,3	36	0,14	11,2	15,6	36	0,19	18,6

			Supply water temperature: 55 °C Room temperature: +18 °C Outlet air temperature: +35 °C*1				Water temperature: 55/35 °C Room temperature: +18 °C			
Type	Fan position	Airflow [m³/h]	Output [kW]	Return water temp. [°C]	Water flow [l/s]	Pressure drop [kPa]	Output *2 [kW]	Outlet air temp. [°C]	Water flow [l/s]	Pressure drop [kPa]
AR3210CW	max	1500	8,8	46	0,24	44,9	6,65	31	0,08	6,5
	min	1000	5,9	39	0,09	7,51	5,2	33	0,06	4,1
AR3215CW	max	2600	15,2	46	0,41	174	11,9	32	0,14	26,5
	min	1700	10,0	39	0,15	29,4	9,17	34	0,11	16,5
AR3220CW	max	3150	18,2	44	0,40	74,1	14,8	32	0,18	17,1
	min	2500	14,3	40	0,23	27,8	12,8	33	0,15	13,2

*1) Recommended outlet air temperature for good comfort and optimized output.

*2) Nominal output at given supply and return water temperature.

AR3200C

AR3200CA

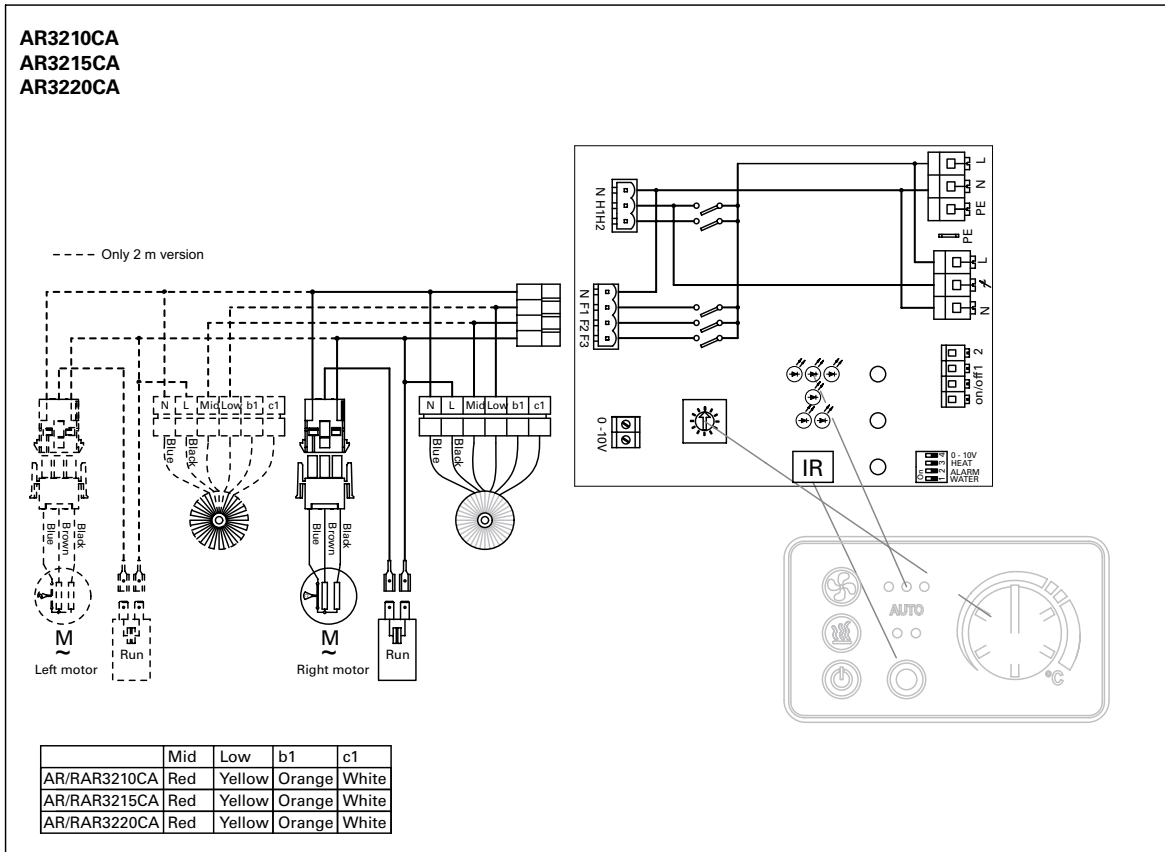

AR3200CW

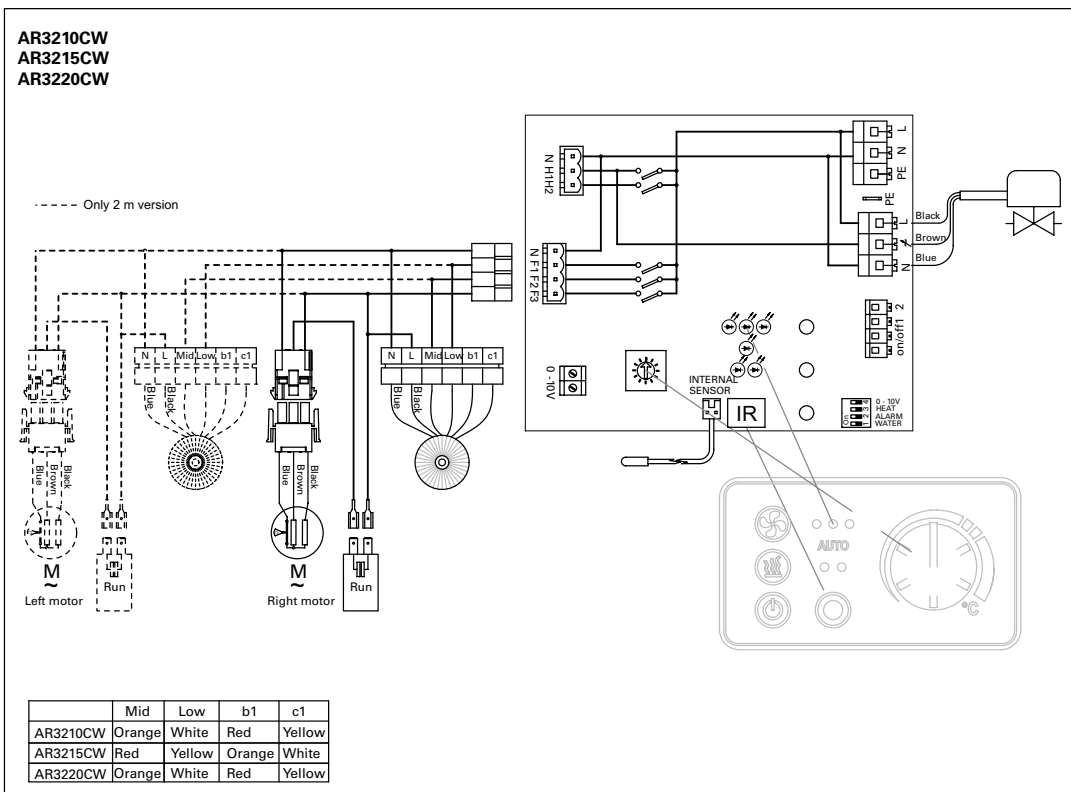

AR3200C

AR3210CE03

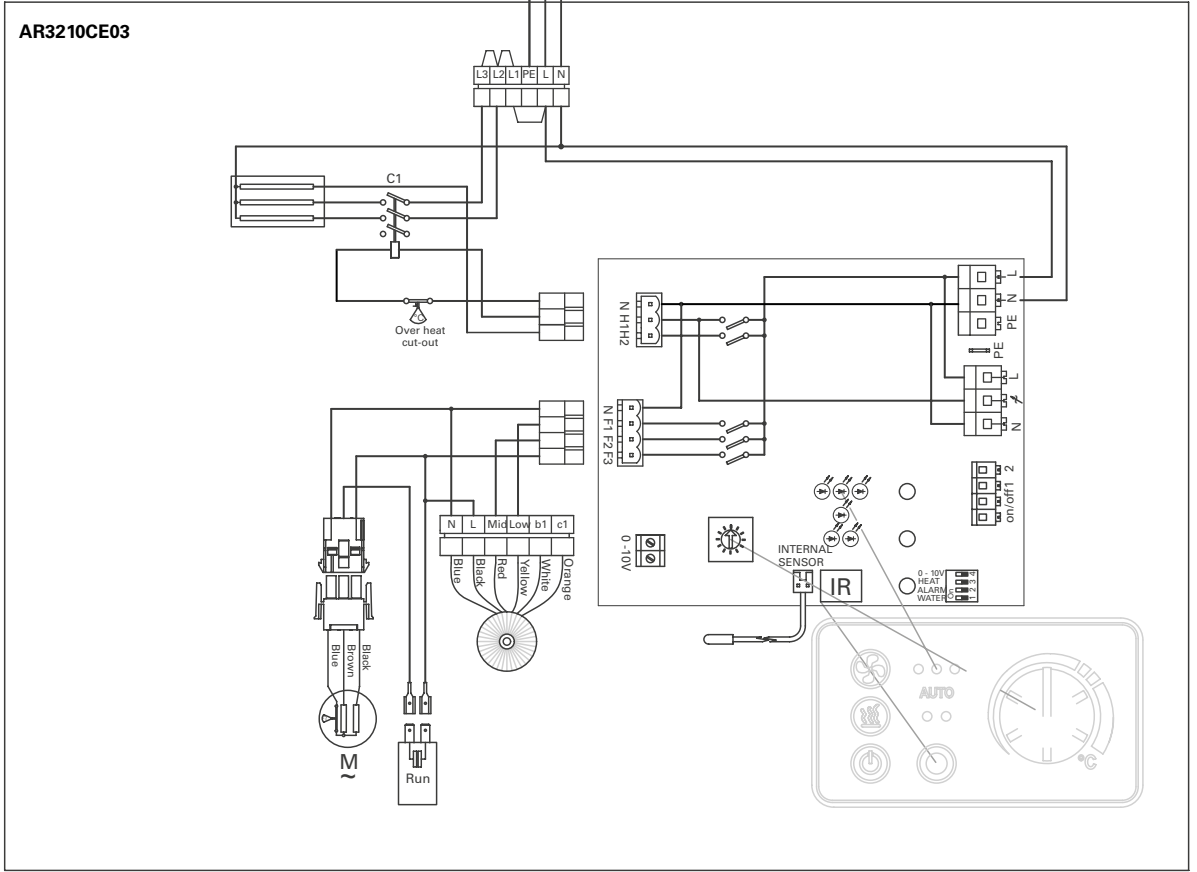

AR3210CE05

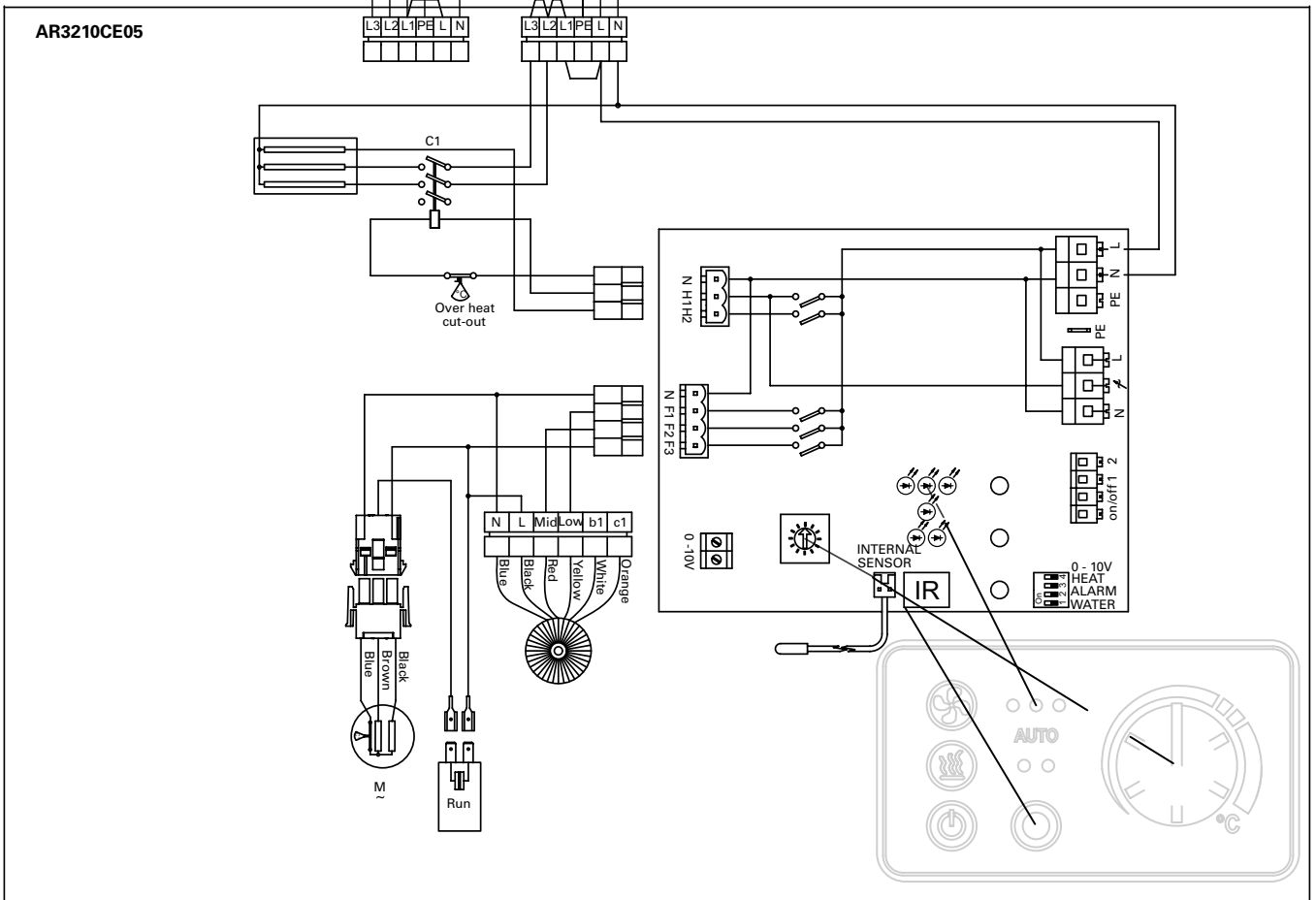

AR3200C

AR3210CE08
AR3215CE12

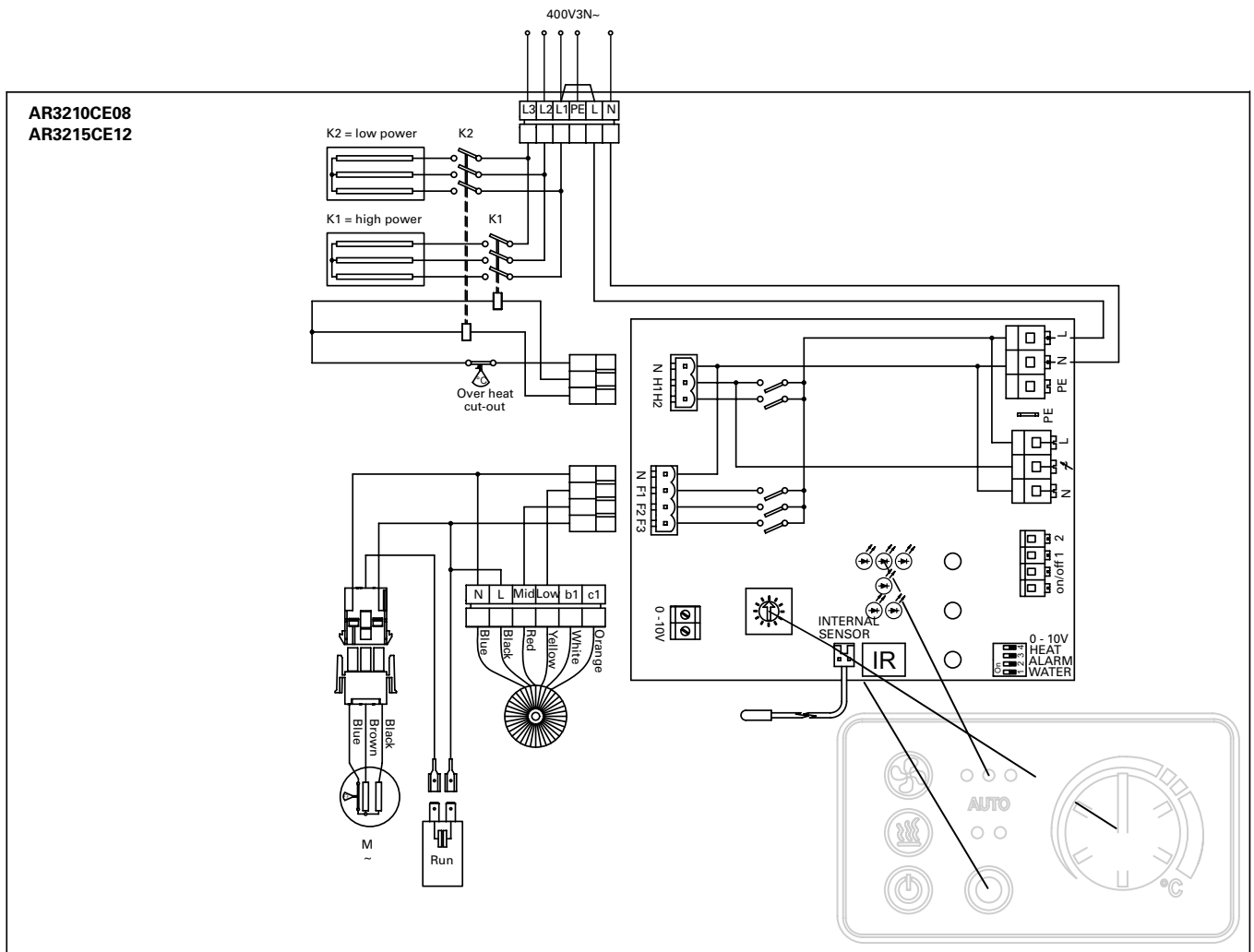

AR3215CE08

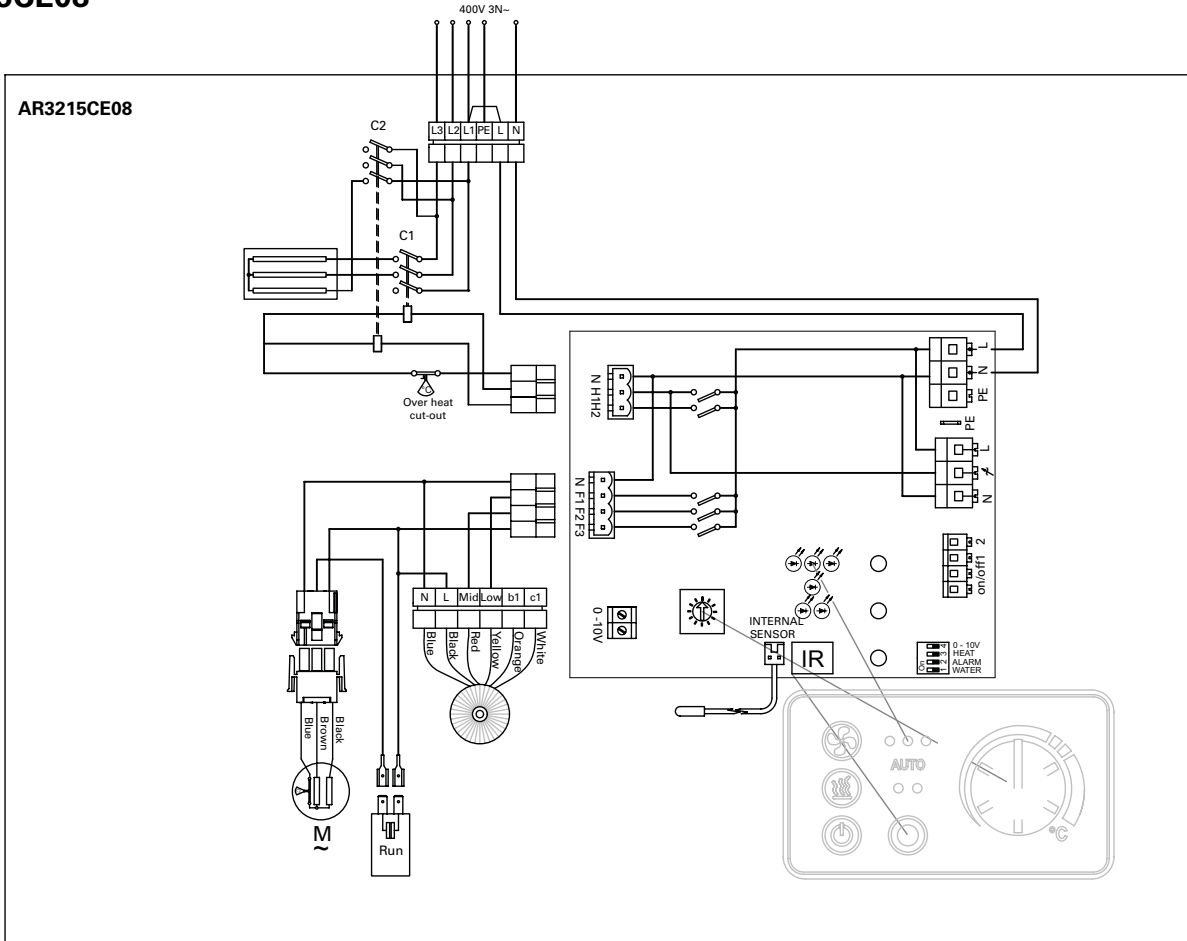

AR3220CE10

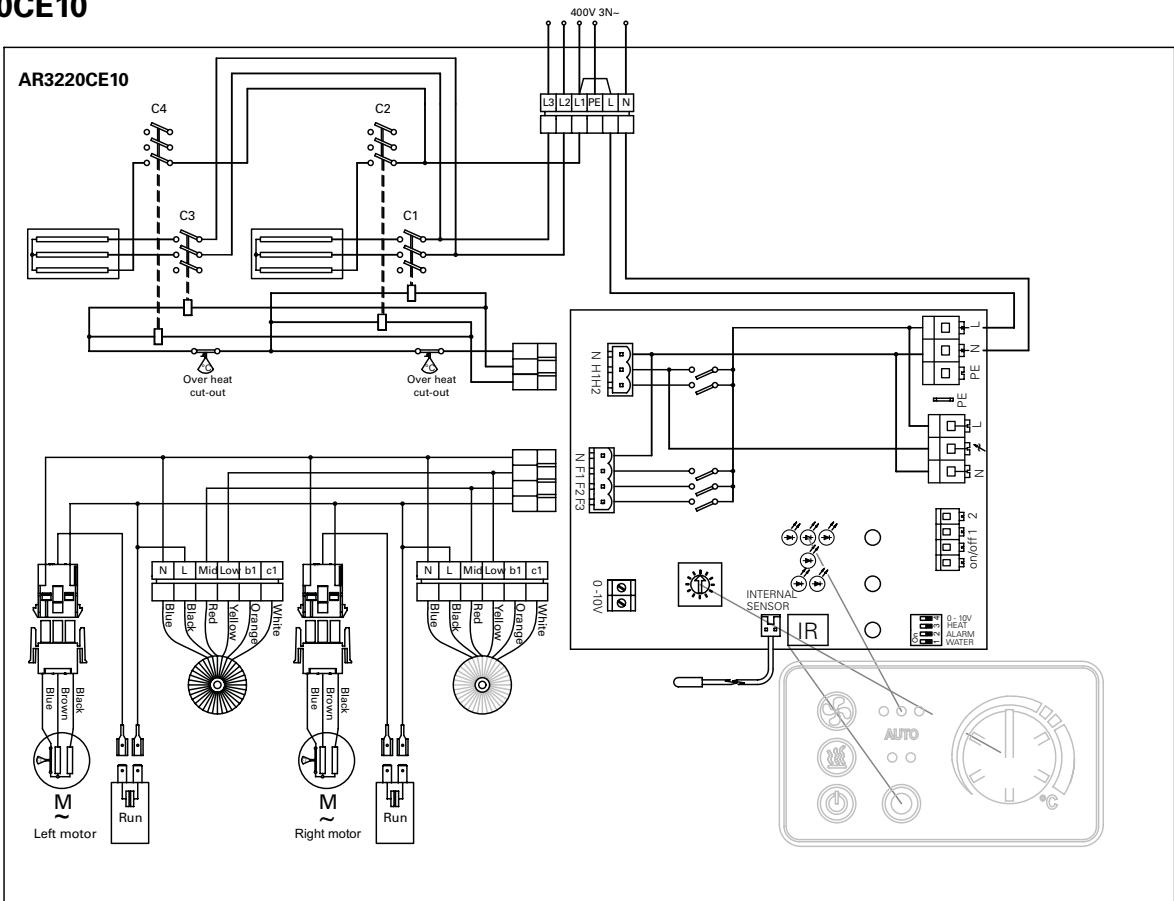

AR3220CE16

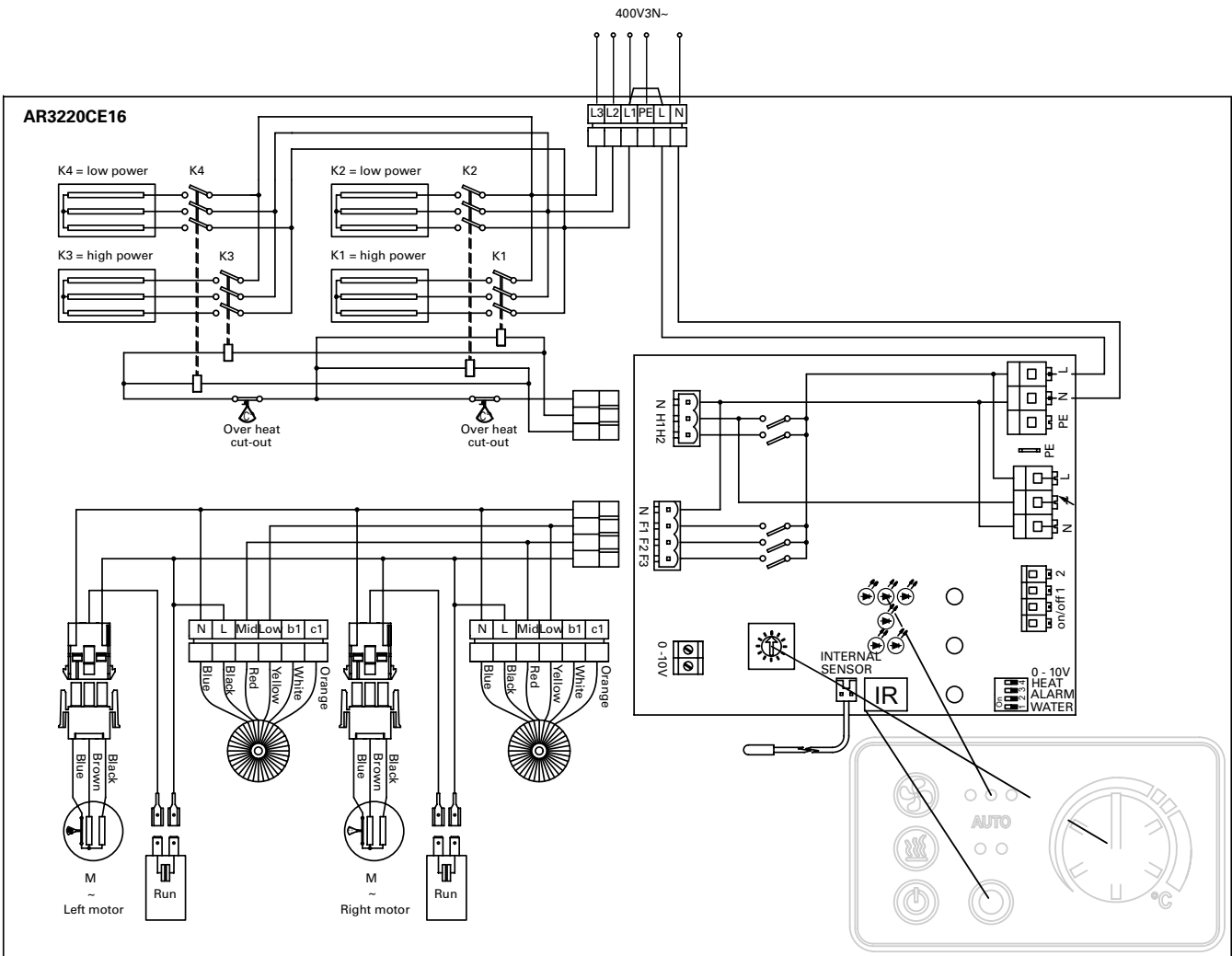

PAMLK

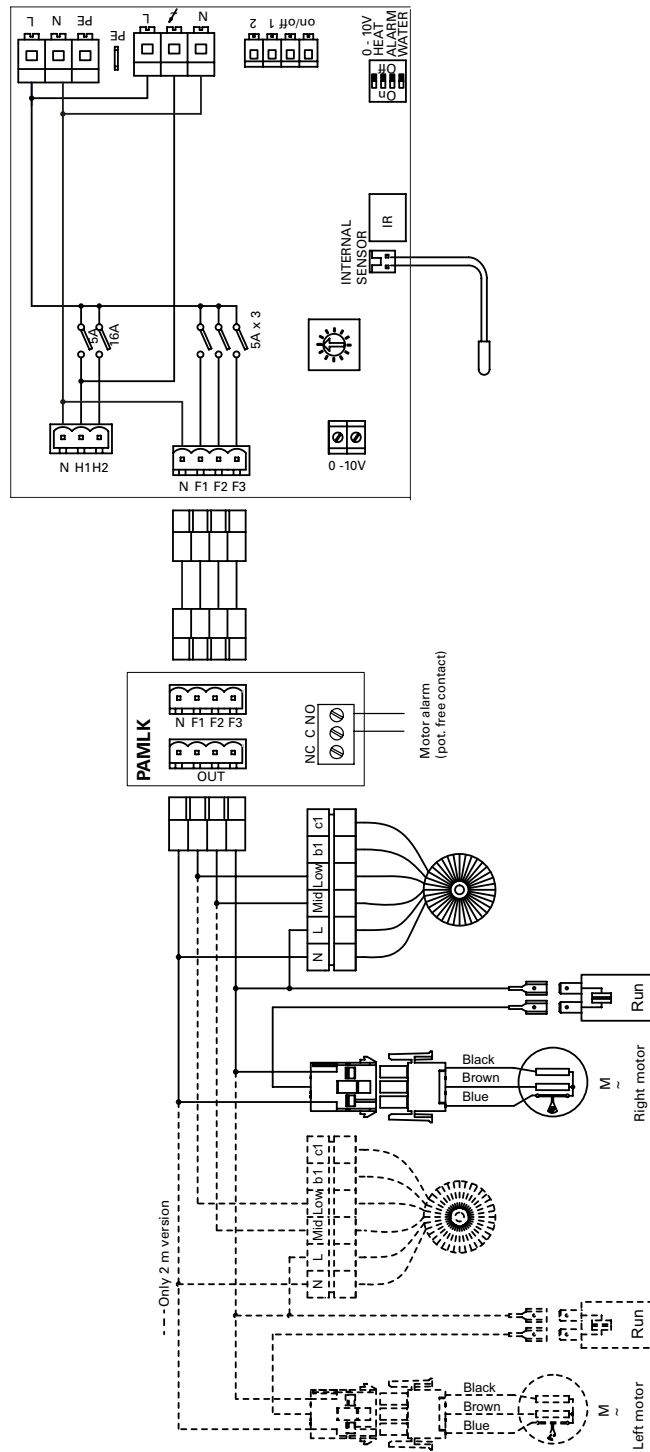

Installation and operating instructions

General Instructions

Read these instructions carefully before installation and use. Keep this manual for future reference.

The product may only be used as set out in the assembly and operating instructions. The guarantee is only valid if the product is used in the manner intended and in accordance with the instructions.

Application area

AR3200C is a compact air curtain for recessed mounting. The air curtain is available without heat, with electrical heating and with water heating. Recommended installation height for ambient and electrically heated units is 3,2 metres and recommended installation height for water heated unit is 2,8 metres. The air curtain has an integrated control system and can also be remote controlled.

Protection class for units with electrical heating: IP20.

Protection class for units without heating and units with water heating: IP21.

Operation

Air is drawn in from underneath and blown out downwards so that it protects the door opening and minimizes heat loss. To achieve the optimum curtain effect the unit must extend the full width of the opening.

The grille for directing exhaust air is adjustable and is normally angled outwards to achieve the best protection against incoming air.

The efficiency of the air curtain depends on the air temperature, pressure differences across the doorway and any wind pressure.

NOTE! Negative pressure in the building considerably reduces the efficiency of the air curtain. The ventilation should therefore be balanced.

Mounting

The air curtain is installed horizontally with the supply air grille facing downwards as close to the door as possible, concealed in the false ceiling. The only visible part of the unit is

the underside which is level with the ceiling. The service hatch must be accessible, nothing should prevent it being fully opened.

The unit is ready for suspension with threaded bars on its outside. The threaded bars can also be fixed on the inside of the unit e.g. when mounted on a solid suspended ceiling.

For the protection of wider doorways, several units can be mounted next to each other. Minimum distance from outlet to floor for electrically heated units is 1800 mm.

Mounting on threaded bars outside the unit

1. The mounting brackets are fixed to the unit during transport. Slacken these, turn them around and screw into place on the unit according to fig. 1a.
2. Hang on threaded bars (M8) according to fig. 1b (accessory).
3. Adjust the height using the lower nut so that the frame is in level with the ceiling. Lock using the upper nut.

Mounting on threaded bars inside the unit

1. The mounting brackets are fixed to the unit during transport. Loosen them and screw them into place inside the unit in the intended holes. In order to mount the brackets, remove the service hatch, outlet grille and covering plates. See pages 6-7.
2. Hang on threaded bars (M8) according to fig. 2b (accessory).
3. Adjust the height using the lower nut so that the frame is in level with the ceiling. Lock using the upper nut.

Electrical installation

The installation, which should be preceded by an omnipolar switch with a contact separation of at least 3 mm, should only be wired by a competent electrician and in accordance with the latest edition of IEE wiring regulations. The control system is pre-installed in the air curtain.

Unit without heating or with water heating

The electrical connection is made on the front or on the top of the unit. Control (230V~) should be connected to a terminal block in the terminal box.

Unit with electrical heating

The electrical connection is made on the front or on the top of the unit. Control (230V~) and power supply for heat (400V3~) should be connected to a terminal block in the terminal box.

The cable glands used must meet the protection class requirements. The largest cable diameter for the terminal block is 16 mm².

See wiring diagrams.

Type	Output Voltage		Minimum area* [mm ²]
	[kW]	[V]	
Control	0	230V~	1,5
AR3210CE03	3	230V~	2,5
AR3210CE05	5	230V~/400V3N~	6/1,5
AR3210CE08	8	400V3N~	2,5
AR3215CE08	8	400V3N~	2,5
AR3215CE12	12	400V3N~	4
AR3220CE10	10	400V3N~	2,5
AR3220CE16	16	400V3N~	6

*) Dimensioning of external wiring shall comply with applicable regulations and local deviations may occur.

Start-up (E)

When the unit is used for the first time or after a long period of disuse, smoke or odour may result from dust or dirt that has collected on the element. This is completely normal and disappears after a short time.

Connecting the water coil (W)

The installation must be carried out by an authorised installer.

The water coil has copper tubes with aluminium fins and is suitable for connection to a closed water heating system. The heating coil must not be connected to a mains pressure water system or an open water system.

Note that the unit shall be preceded by a regulating valve, see Frico valve kit.

The connections to the heating coil must be equipped with shut off valves to allow problem free removal. Water coil is equipped with a drain and a vent valve. The water coil is connected via connections with dimensions DN15 (1/2"), outside thread, inside the unit. Knockouts are placed on the top and the side of the unit.

NOTE: Care must be taken when connecting the pipes. Use a wrench or similar to hold the air curtain connections to prevent straining of the pipes and subsequent water leakage during connection to water supply pipe-work.

Adjustment of the air curtain and air flow

The direction and speed of the air flow should be adjusted considering the load on the opening. Pressure forces affect the air stream and make it bend inwards into the premises (when the premises are heated and the outdoor air is cold).

The air stream should therefore be directed outwards to withstand the load. Generally speaking, the higher the load, the greater the angle that is needed.

Basic setting fan speed

The fan speed when the door is open is set using the control. Note that the air flow direction and fan speed may need fine adjustment depending on the loading of the door.

Filter (W)

The water coil is protected against dirt and blockage by an internal air filter which covers the coil face.

Service, repairs and maintenance

For all service, repair and maintenance first carry out the following:

1. Disconnect the power supply.
2. The service hatch is opened by loosening the snap fixings located on the bottom of the unit (turn 90°). The hatch must be held when the snap fixings are loosened. See fig. 3a and 3b.
3. After service, repairs and maintenance close the service hatch and make sure that the snap fixings lock properly.

Maintenance

Unit with water heating

The appliance filter should be cleaned regularly to ensure the air curtain effect and the heat emission from the device. How often depends on local circumstances. A clogged filter is not a risk, but the appliance function can fail.

1. Disconnect the power supply.
2. The service hatch is opened by loosening the snap fixings located on the bottom of the unit (turn 90°). The hatch must be held when the snap fixings are loosened. See fig. 3a and 3b.
3. Remove the filter and vacuum clean or wash it. If the filter is clogged or damaged, it may need to be changed.

All units:

Since fan motors and other components are maintenance free, no maintenance other than cleaning is necessary. The level of cleaning can vary depending on local conditions. Undertake cleaning at least twice a year. Inlet and exhaust grilles, impeller and elements can be vacuum cleaned or wiped using a damp cloth. Use a brush when vacuuming to prevent damaging sensitive parts. Avoid the use of strong alkaline or acidic cleaning agents.

Overheating

The air curtain unit with electric heater is equipped with an overheat protector. If it is deployed due to overheating, reset as follows:

1. Disconnect the electricity with the fully isolated switch.
2. Determine the cause of overheating and rectify the fault.
3. Open the service hatch. Locate the red button next to the terminal box inside the air curtain. The 2 metre unit is equipped with two red buttons, one on each terminal box.
4. Press the red button until a click is heard.
5. Connect the unit again.

All motors are equipped with an integral thermal safety cut-out. This will operate, stopping the air curtain should the motor temperature rise too high. The cut-out will automatically reset when the motor temperature has returned to within the motor's operating limits.

Temperature control

See control pages.

Replacing motor or impeller

1. Remove frame and side panel.
2. Remove the screw between motor and fan.
3. Disconnect the cables to the motor.
4. Remove the screws securing the motor and lift it out together with the impeller.
5. Install the new motor and/or the new impeller as above in reverse order.

Replacing heating elements/heating package (E)

1. Mark and disconnect the cables to the heating elements/package
2. Remove the mounting screws securing the heating elements/package in the unit and lift the heating elements/package out.
3. Install the new heating elements/package in reverse order to the above.

Replacing the water coil (W)

1. Shut off the water supply to the unit.
2. Open the vent valve.
3. Open the drain valve.
4. When the water coil is empty, disconnect its connections.
5. Remove the covering plate.
6. Remove the mounting screws securing the coil in the unit and lift the coil out.
7. Move the filter to the new unit.
8. Install the new coil in reverse order to the above.

Draining the water coil (W)

The drain valve is on the underside of the coil on the connector side. It can be accessed via the service hatch.

Trouble shooting

If the fans are not working or do not blow properly, check the following:

- The functions and settings of the built-in control system.
- That the intake grille/filter is not dirty.

If there is no heat, check the following:

- The functions, internal sensor and settings of the built-in control system.

For units with electrical heating, also check the following:

- Power supply to electric heater coil; check fuses and circuit-breaker (if any).
- That the overheat protection for the motors has not been deployed.

For units with water coil, also check the following:

- That the water coil is air free.
- That there is enough water flow.
- That incoming water is heated enough.

If the fault cannot be rectified, please contact a qualified service technician.

Residual current circuit breaker (E)

When the installation is protected by means of a residual current circuit breaker, which trips when the appliance is connected, this may be due to moisture in the heating element. When an appliance containing a heater element has not been used for a long period or stored in a damp environment, moisture can enter the element.

This should not be seen as a fault, but is simply rectified by connecting the appliance to the main supply via a socket without a safety cut-out, so that the moisture can be eliminated from the element. The drying time can vary from a few hours to a few days. As a preventive measure, the unit should occasionally be run for a short time when it is not being used for extended periods of time.

Packaging

Packaging materials are chosen with consideration to environment and are therefore recyclable.

Handling of product at end of working life

This product may contain substances necessary for functionality of product but potentially dangerous for the environment. The product should not be disposed mixed with general household waste but delivered to a designated collection point for environmental recycling. Please contact local authority for further details of your nearest designated collection point.

Safety

- *For all installations of electrically heated products should a residual current circuit breaker 300 mA for fire protection be used.*
- *Keep the areas around the air intake and exhaust grilles free from possible obstructions!*
- *The unit must not be fully or partially covered as overheating can result in a fire risk!*
- *Lifting equipment must be used to lift the unit.*
- *This appliance can be used by children aged from 8 years and above and persons with reduced physical, sensory or mental capabilities or lack of experience and knowledge if they have been given supervision or instruction concerning use of the appliance in a safe way and understand the hazards involved. Children shall not play with the appliance. Cleaning and user maintenance shall not be made by children without supervision.*
- *Children of less than 3 years should be kept away unless continuously supervised.*
- *Children aged from 3 years and less than 8 years shall only switch on/off the appliance provided that it has been placed or installed in its intended normal operating position and they have been given supervision or instruction concerning use of the appliance in a safe way and understand the hazards involved.*
- *Children aged from 3 years and less than 8 years shall not plug in, regulate and clean the appliance or perform user maintenance.*

CAUTION — Some parts of this product can become very hot and cause burns. Particular attention has to be given where children and vulnerable people are present.

Control

The control system is integrated in the air curtain. The air curtain can be regulated with a remote control or by the control panel placed inside the service hatch.

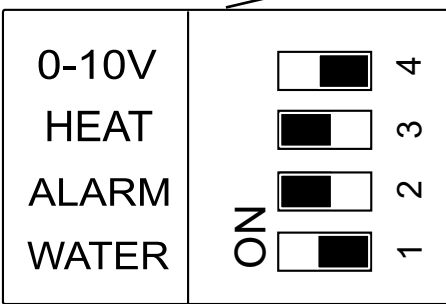
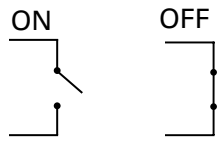
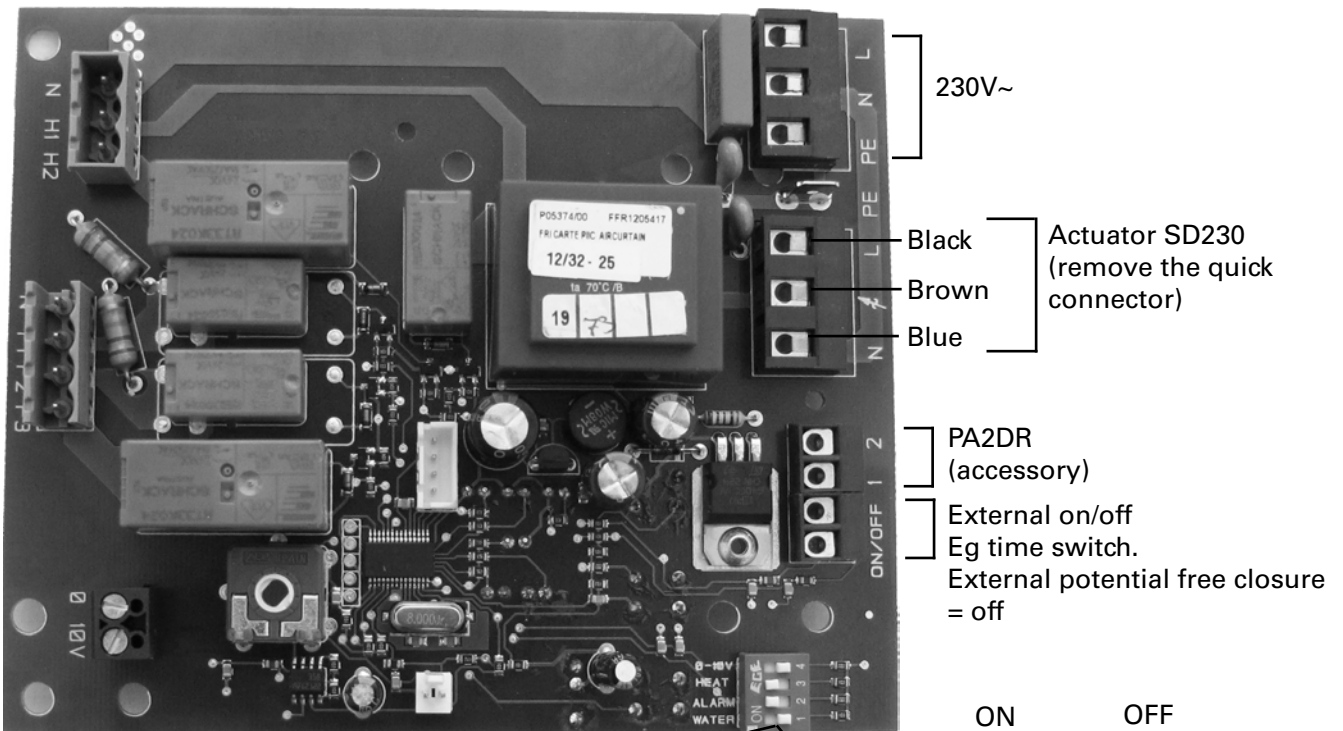
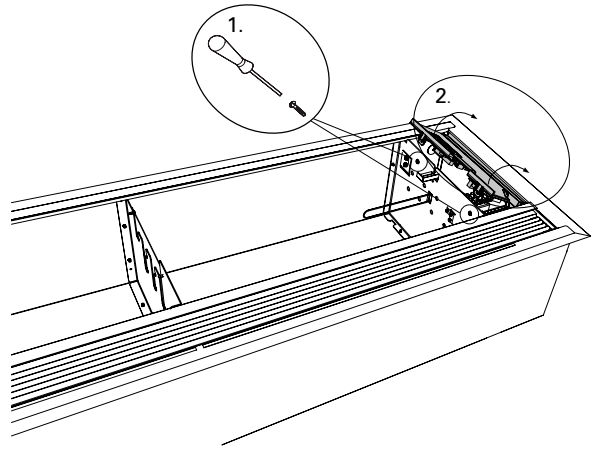

Factory setting dip-switches - Unit without heating or with electrical heating

Dip-switch 3 is used for PA2DR (optional).

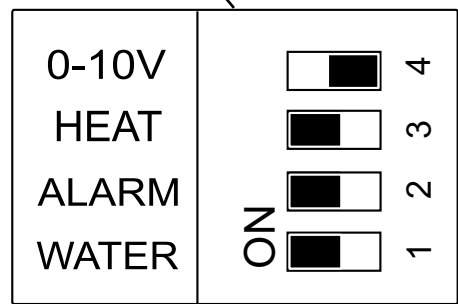

Factory setting dip-switches - Unit with water heating

Dip-switch 3 is used for PA2DR (optional).

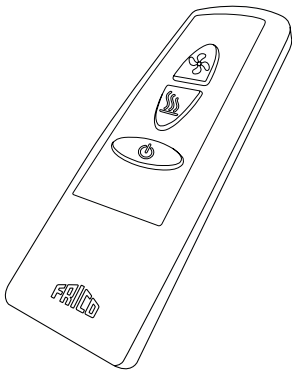
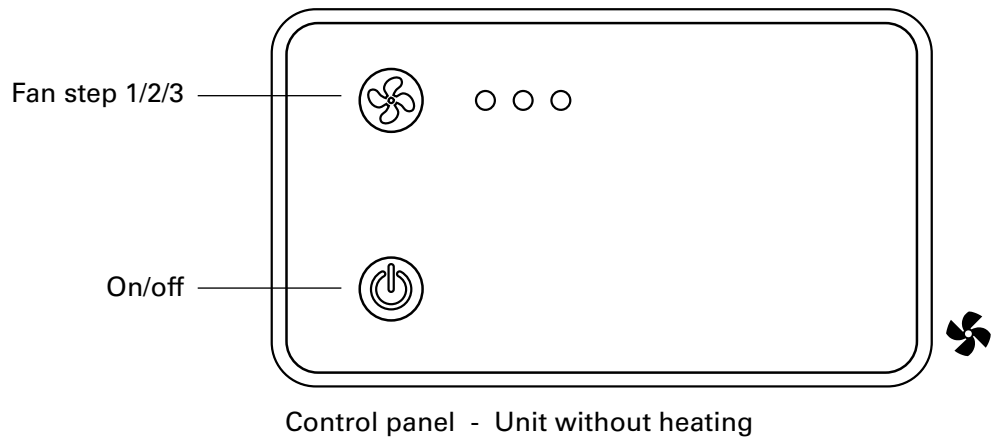
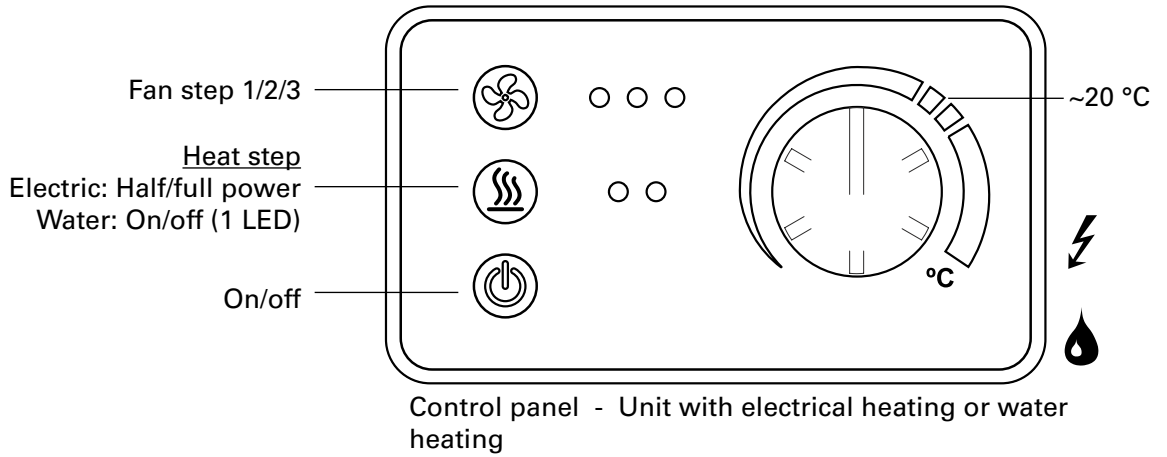

Remote control - on/off, fan steps and heating steps

Functional test

Functional test is started using the remote control.

Push



and



in 5 seconds

Fan and heatings steps are tested in 10-second intervals which is indicated by lighted LEDs. When the test is completed, all LEDs will flash for 30 seconds.

Temperature control

If the temperature exceeds 50 °C, the fan runs at full speed for 2 minutes to vent out the heat, if the temperature rises above 50 °C again during the following 5 minutes overheating alarm is deployed. The red LEDs flash and all the buttons are locked.

1. Disconnect the electricity with the fully isolated switch.
2. Determine the cause of overheating and rectify the fault.
3. Connect the unit again.



Main office

Frico AB
Industrivägen 41
SE-433 61 Sävedalen
Sweden

Tel: +46 31 336 86 00

mailbox@frico.se

www.frico.net

**For latest updated information and information
about your local contact: www.frico.net.**