

EN 15650:2010-09

MANDÍK[®]

FIRE DAMPER FDMR



These Technical Specifications define the range of the manufactured sizes and models, the main dimensions and the scope of use of the FDMR fire dampers (hereinafter referred to only as the "fire dampers"). They are binding for production, designing, ordering, delivery, storage, assembly, operation, maintenance and operability inspections.

I. CONTENT

II. GENERAL INFORMATION	3
1. Description.....	3
2. Design.....	4
3. Communication and control devices.....	16
4. Dimensions, weights and effective area.....	19
5. Placement and Assembly	25
6. Statement of installations.....	27
7. Thin shaft wall.....	66
8. Installation frames.....	69
9. Suspension system.....	77
III. TECHNICAL DATA	85
10. Pressure loss.....	85
11. Coefficient of local pressure loss.....	86
12. Noise data.....	86
IV. MATERIAL, FINISHING	88
13. Material.....	88
V. INSPECTION, TESTING	89
14. Inspection.....	89
15. Testing.....	89
VI. TRANSPORTATION AND STORAGE	89
16. Logistic terms.....	89
17. Warranty.....	89
VII. ASSEMBLY, ATTENDANCE, MAINTENANCE AND REVISIONS	90
18. Assembly.....	90
19. Entry into service and revisions.....	91
20. Spare parts.....	92
21. Restore function of actuating mechanism after fuses initiation.....	92
VIII. ORDERING INFORMATION	93
22. Ordering key.....	93
IX. PRODUCT DATA	94
23. Data label.....	94

II. GENERAL INFORMATION

1. Description

- 1.1.** Fire dampers are shutters in ducts of air-conditioning devices that prevent spreading the fire and combustion products from one fire segment to the other one by means of closing the duct in the points of fire separating constructions.

The damper blade automatically closes the air duct using a shutting spring or an actuating mechanism of back spring. The shutting spring is activated by pressing the start button or by the impulse from the thermal fuse. The back spring of the actuating mechanism is started when the thermoelectric starting mechanism BAT is activated, when the reset button on BAT is pressed or when the power supply to the actuating mechanism is stopped.

After closing the blade, the damper is sealed with a silicon packing against smoke penetration. The damper can be delivered with a seal without silicone at the customer's wish. At the same time, the damper blade is embedded in a material which enlarges its volume due to increasing temperature and hermetically seals the air duct.

The dampers have one inspection hole, as the shutting device and the inspection hole can be set to the most advantageous position with respect to operation and handling of the control device by turning the damper a little in case of the spiro model of the dampers.

Fig. 1 FDMR with actuating mechanism



Fig. 2 FDMR with mechanical control



- 1.2.** Damper characteristics

- CE certified acc. to EN 15650
- Tested in accordance with EN 1366-2
- Classified acc. to EN 13501-3+A1
- Fire resistance: EIS 120 - 500 Pa, EIS 90, EIS 60
- External Casing leakage class C, Internal leakage class 3 acc. to EN 1751
- Cycling test in class C 10000 acc. to EN 15650
- Corrosion resistant acc. to EN 15650
- ES Certificate of conformity No. 1391-CPR-2021/0145
- Declaration of Performance No. PM/FDMR/01/21/3
- Hygienic assessment of fire dampers - Report No. 1.6/pos/19/19b

- 1.3.** Working conditions

Right damper function is secured under the following conditions:

- a) Maximum air circulation speed: 12 m/s
Maximum pressure difference: 1200 Pa
- b) The air circulation in the whole damper section must be secured as steady on whole surface.

Operation of the dampers does not depend on the direction of air circulation. The dampers can be located in an arbitrary position.

Dampers are suitable for systems without abrasive, chemical and adhesive particles.

Dampers are designed for macroclimatic areas with mild climate according to EN 60 721-3-3.

Temperature in the place of installation is permitted to range from -30°C to +50°C.

2. Design

2.1. Design with mechanical control

Design .01

Design with mechanical control with a thermal protective fuse which actuates the shutting device, after the nominal start temperature 72°C has been reached. Automatic initiation of the shutting device is not activated if the temperature does not exceed 70°C. In case that other start temperatures are required, thermal fuses with nominal start temperature +104°C or +147°C can be supplied (this requirement must be specified in the order).

Fig. 3 Design .01

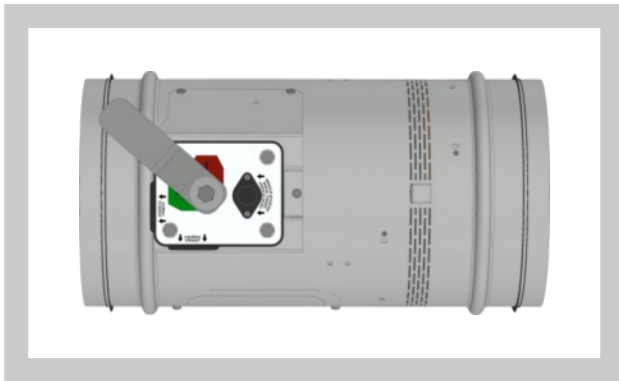

ATTENTION:

Mechanisms are produced in designs **M1** to **M5**, difference is only in size of inner spring, which closes the fire damper. For the size of fire dampers is always assigned the size of mechanism - **Tab 4.1.1**. It is not recommended to use different size of mechanism, than given by the manufacturer, otherwise, there is a risk of fire damper destruction.

Design .11

Design .01 with mechanical control can be complemented with a limit switch signalling of the damper blade position "CLOSED". Cable is connected directly to limit switch.

Fig. 4 Design .11

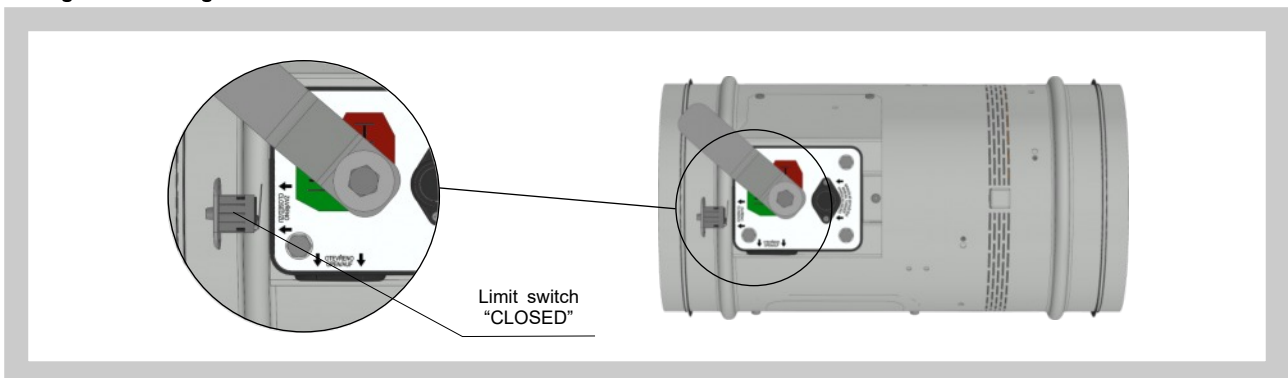

Design .80

Design .01 with mechanical control can be complemented with a terminal switches signaling of the damper blade position "CLOSED" and "OPEN". Limit switches are connected via damper casing, cables are connected directly to limit switches.

Fig. 5 Design .80

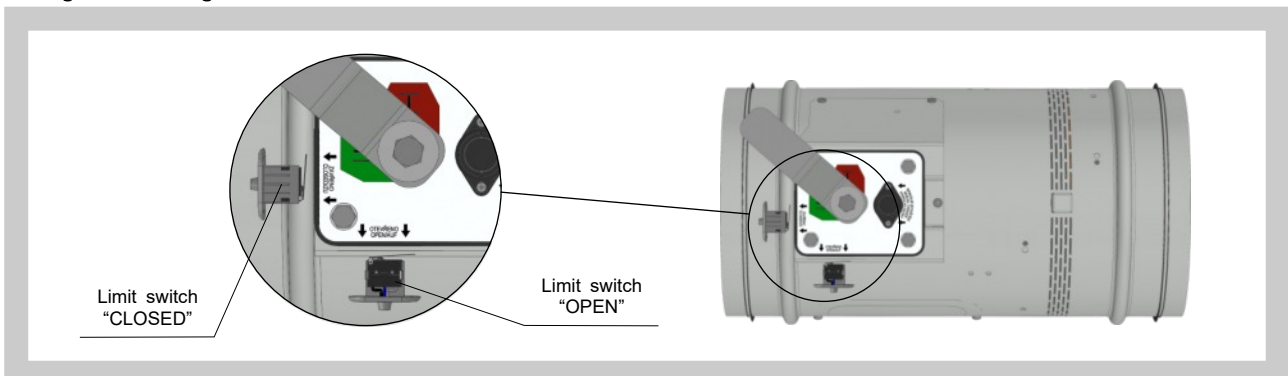



Fig. 6 Limit switch G905-300E03W1



Nominal voltage and maximal current	AC 230V / 5A
Class of protection	IP 67
Working temperature	-25°C ... +120°C

1(COM) - black wire
2(NC) - gray wire
4(NO) - blue wire

This limit switch is possible to connect in following two versions:
a) **CUT-OFF** if the arm is moving ... connect wire 1+2
b) **SWITCH-ON** if the arm is moving ... connect wire 1+4

Fig. 7 Change of mechanical design for the motorised one or vice versa - DN 100 - DN 315

DN 100 - DN 315

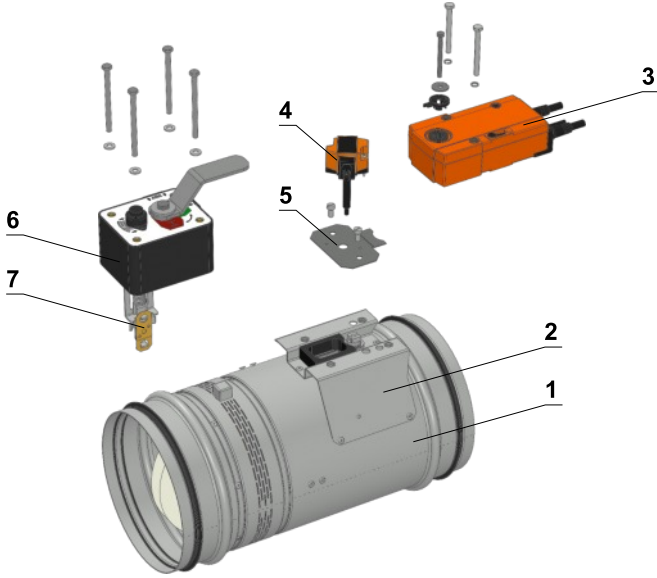

Position:

- 1 Damper
- 2 Mounting plate
- 3 Actuating mechanism
- 4 Temperature sensor
- 5 Mounting plate
- 6 Mechanics
- 7 Thermal fuse

Fig. 8 Change of mechanical design for the motorised one or vice versa - DN 355 - DN 800

DN 355 - DN 800

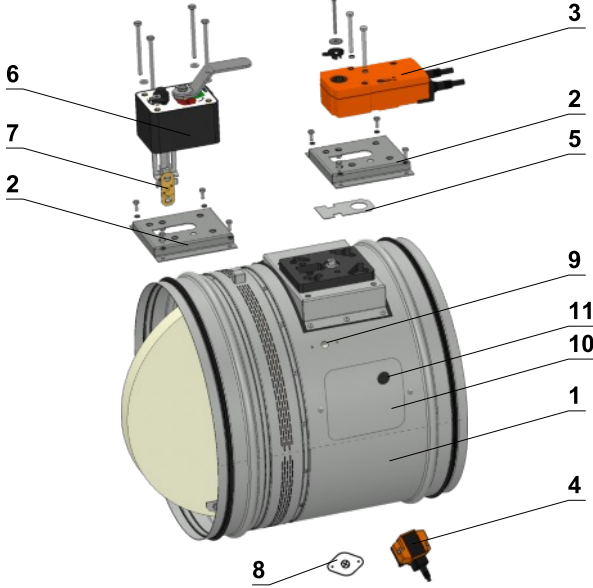

Position:

- 1 Damper
- 2 Mounting plate
- 3 Actuating mechanism
- 4 Temperature sensor
- 5 Mounting plate
- 6 Mechanics
- 7 Thermal fuse
- 8 Sensor sticker
- 9 Hole for temperature sensor / Sensor sticker
- 10 Inspection hole covering
- 11 Hole for camera

2.2. Design with actuating mechanism

Design .40, .50

The dampers are equipped with Belimo actuating mechanisms with back spring and thermoelectric actuating device, of range BFL, BFN or BF, according to the damper size (hereinafter referred to only as the "actuating mechanism"). After being connected to power supply AC/DC 24V or AC 230V, respectively, the actuating mechanism moves the damper blade to "OPEN" operation position and at the same time pre-stretches its back spring. While the actuating mechanism is under voltage, the damper blade is in the "OPEN" position and the back spring is pre-stretched. The time needed for full opening of the damper blade from "CLOSED" position to "OPEN" position is 120 seconds at the maximum. If the power supply to the actuating mechanism is cut off (due to loss of power supply or by pressing the reset button on the BAT thermoelectric starting mechanism), the back spring will move the damper blade to "CLOSED" position. The time of moving the blade from "OPEN" position to "CLOSED" position takes 20 seconds at the maximum. If the power supply is restored (the blade can be in any position), the actuating mechanism starts to move the damper blade to "OPEN" position again.

A thermoelectrical starting mechanism BAT, which contains two thermal fuses Tf1 and Tf2, is a part of the actuating mechanism. These fuses are activated when temperature +72°C has been exceeded (the fuse Tf1 when the temperature around the damper and the fuses Tf2 when the temperature inside the air-conditioning piping has been exceeded). After the thermal fuse Tf1 or Tf2 has been activated, the power supply is permanently and irreversibly cut off and the actuating mechanism, by means of the pre-stretched spring, displaces the damper blade into the breakdown position "CLOSED".

Signalisation of damper blade position "OPEN" and "CLOSE" is provided by two limit switches.

Fig. 9 Design .40, .50

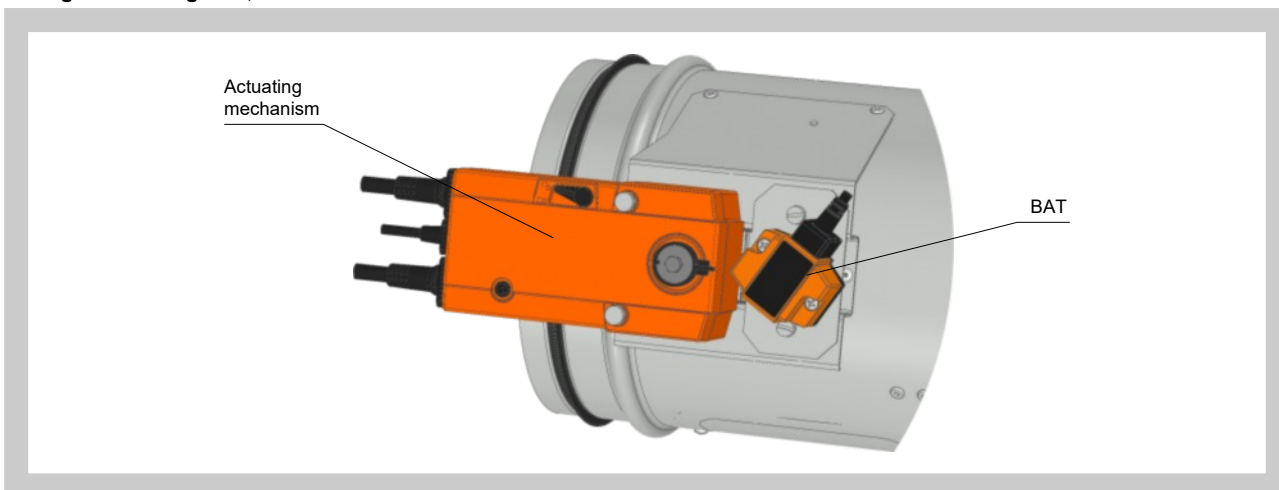

Fig. 10 Actuating mechanism BELIMO BFL (BFN) 230-T

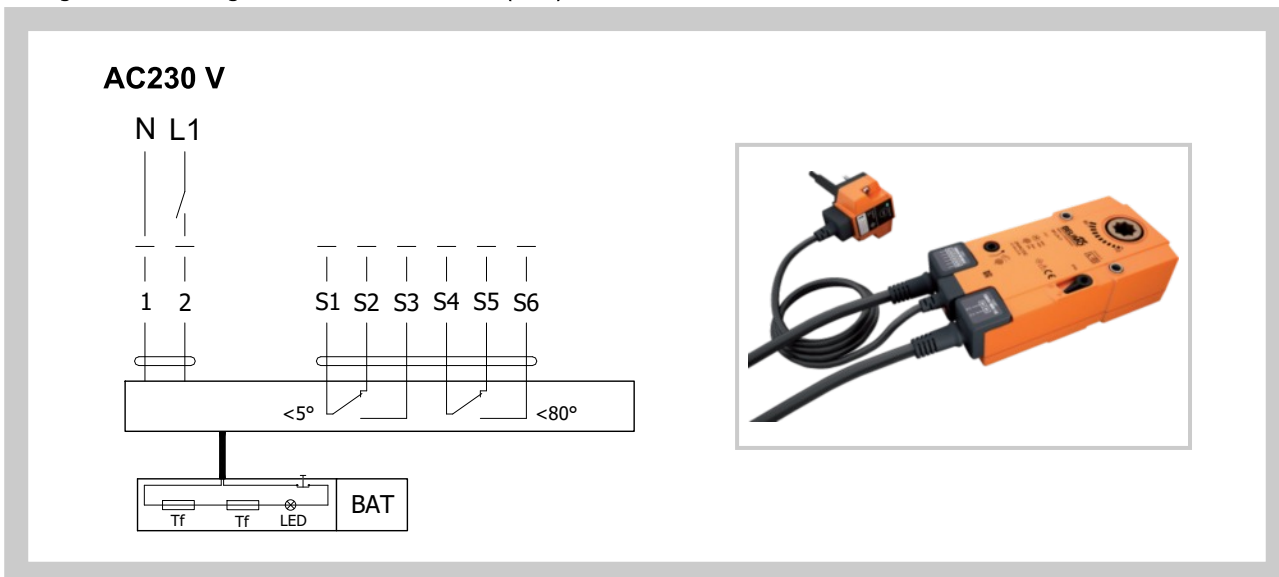
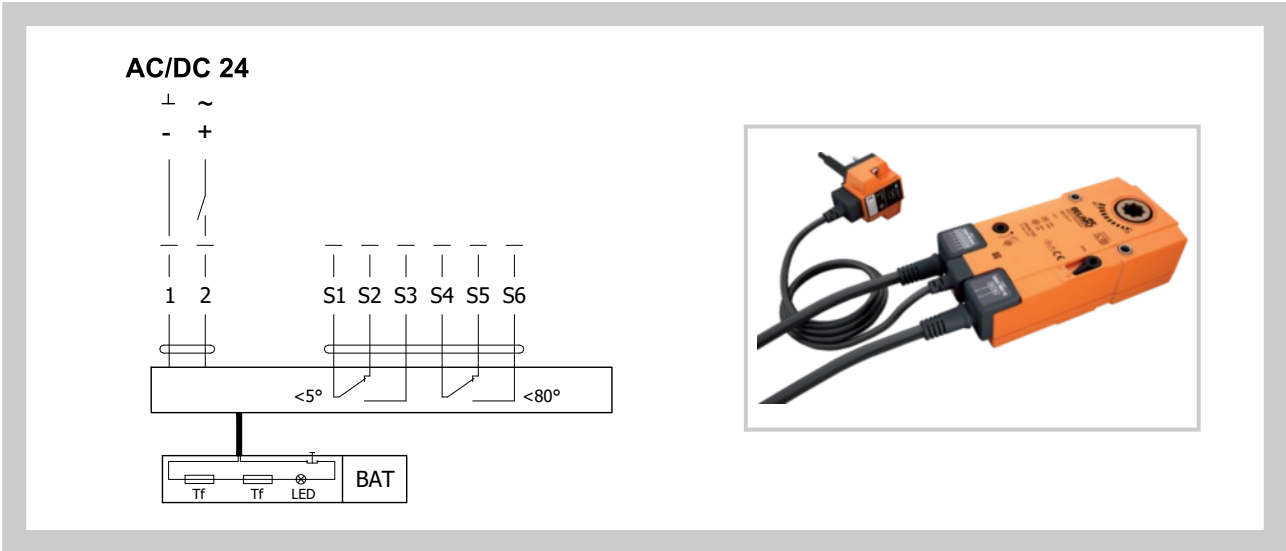

Fig. 11 Actuating mechanism BELIMO BFL (BFN) 24-T(-ST)



Tab. 2.2.1. Actuating mechanism BELIMO BFL 24-T(-ST), BFN 24-T(-ST), BFL 230-T and BFN 230-T

Actuating mechanism BELIMO	BFL, BFN 230-T	BFL, BFN 24-T(-ST)
Nominal voltage	AC 230 V 50/60 Hz	AC 24 V 50/60 Hz DC 24 V
Power consumption - motoring - holding	3,5/5 W 1,1/2,1 W	2,5/4 W 0,8/1,4 W
Dimensioning	6,5/10 VA (I _{max} 4 A @ 5 ms)	4/6 VA (I _{max} 8,3 A @ 5 ms)
Protection class	II	III
Degree of protection	IP 54	
Running time - motor - spring return	<60 s ~ 20 s	
Ambient temperature - normal duty - safety duty - non-operating temperature	- 30°C ... +55°C The safe position will be attained up to max. +75°C - 40°C ... +55°C	
Connecting - motor - auxiliary switch	cable 1 m, 2 x 0,75 mm ² (BFL/BFN 24-T(-ST)) with 3-pin plug-in connectors cable 1 m, 6 x 0,75 mm ² (BFL/BFN 24-T(-ST)) with 6-pin plug-in connectors	
Thermal trips	duct outside temperature +72°C duct inside temperature +72°C	

Fig. 12 Actuating mechanism BELIMO BF 230-TN, BF 24-TN (-ST)

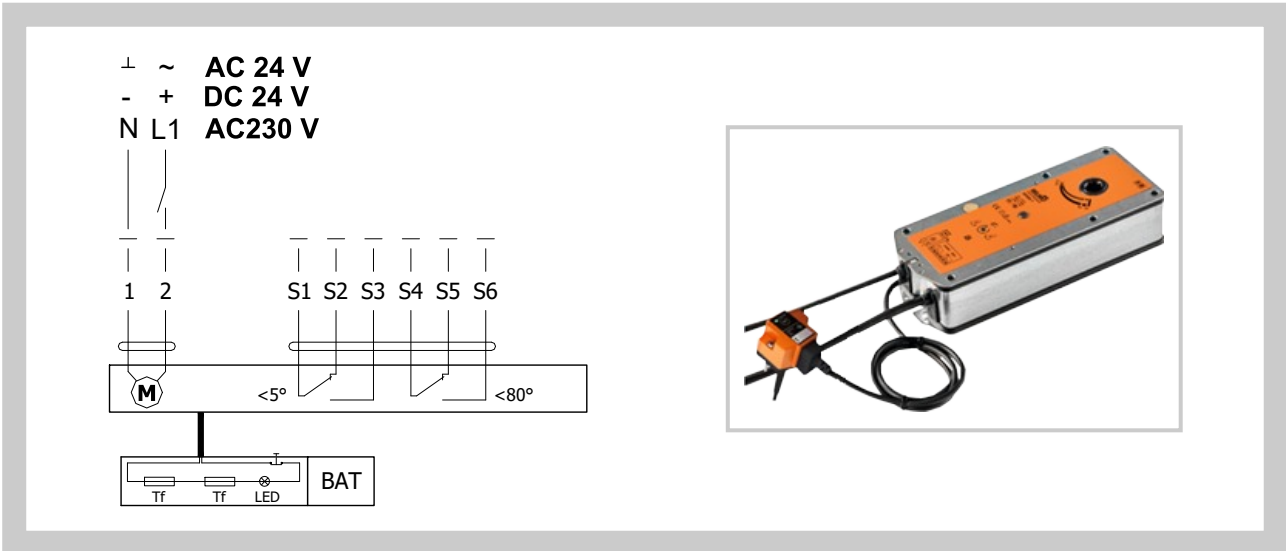

Tab. 2.2.2. Actuating mechanism BELIMO BF 24-TN(-ST), BF 230-TN

Actuating mechanism BELIMO	BF 24-TN(-ST)	BF 230-TN
Nominal voltage	AC 24 V 50/60 Hz DC 24 V	AC 230 V 50/60 Hz
Power consumption - motoring - holding	7 W 2 W	8 W 3 W
Dimensioning	10 VA (Imax 8,3 A @ 5 ms)	12,5 VA (Imax 500 mA @ 5 ms)
Protection class	III	II
Degree of protection	IP 54	
Running time - motor - spring return	120 sec ~ 16 sec	
Ambient Temperature - normal duty - safety duty - non-operating temperature	-30°C ... +50°C The safe position will be attained up to max. 75°C -40°C ... +50°C	
Connecting - motor - auxiliary switch	cable 1 m, 2 x 0,75 mm ² cable 1 m, 6 x 0,75 mm ² (BF 24-T-ST) with plug-in connectors	
Thermal trips	Tf1: duct outside temperature Duct +72°C Tf2/Tf3: duct inside temperature Duct +72°C	

Design .41, .51

Design .41 or .51 with actuating mechanism can be complemented with smoke detector ORS 142 K. The voltage can be AC 230 V or 24 V DC. Design with voltage AC 230 V is equipped with Communication and supply device BKN 230-24-MOD and with actuating mechanism BF 24-TN (BFL 24-T, BFN 24-T).

The smoke detector is activated when smoke spreads in air duct system. Deactivation of smoke detector is provided by interruption of supply voltage for min. 2s.

Signalisation of damper blade position "OPEN" a "CLOSE" is provided by two limit switches.

The smoke detector sensor is not part of the fire damper in the case of dampers in diameters from DN 100 mm to DN 200 mm (including). The smoke sensor is supplied separately.

Tab. 2.2.3. Optical smoke detector ORS 142 K with the socket 143A

Optical smoke detector	ORS 142 K with socket 143A
Operating voltage	18 ... 28 V DC
Residual ripple	≤ 200 mV
Power Consumption Socket (without actuating mechanism)	max. 22 mA
Degree of protection	IP 42
Ambient temperature	-20°C ... +75°C
Additional temperature sensor	+70°C
Connection - net - motor - communication and supply device BKN	Cabel 1m, connected to terminals 1, 2 and 4 Actuator connected on the terminals 2 and 5 Cabel 1m, connected to terminals 1, 2, 4 and 5

Fig. 13 Smoke detector ORS 142 K and socket 143A

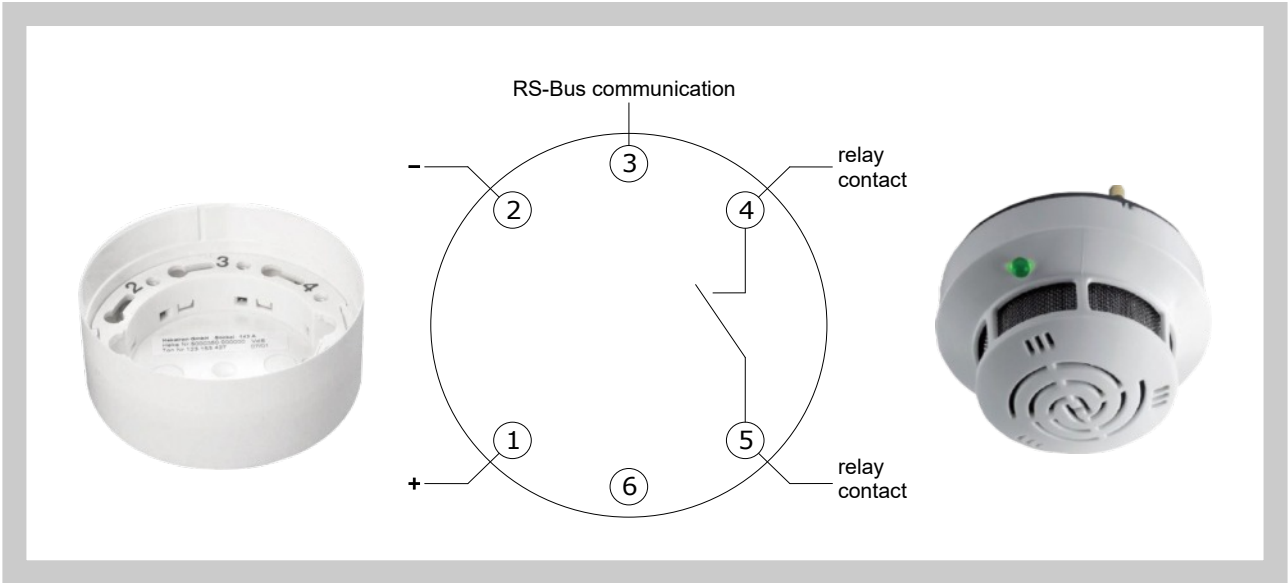

Fig. 14 Design with actuating mechanism BF 24-TN (BFL, BFN 24-T) , with smoke detector ORS 142 K and with communication and supply device BKN 230-24-MOD (voltage AC 230 V)

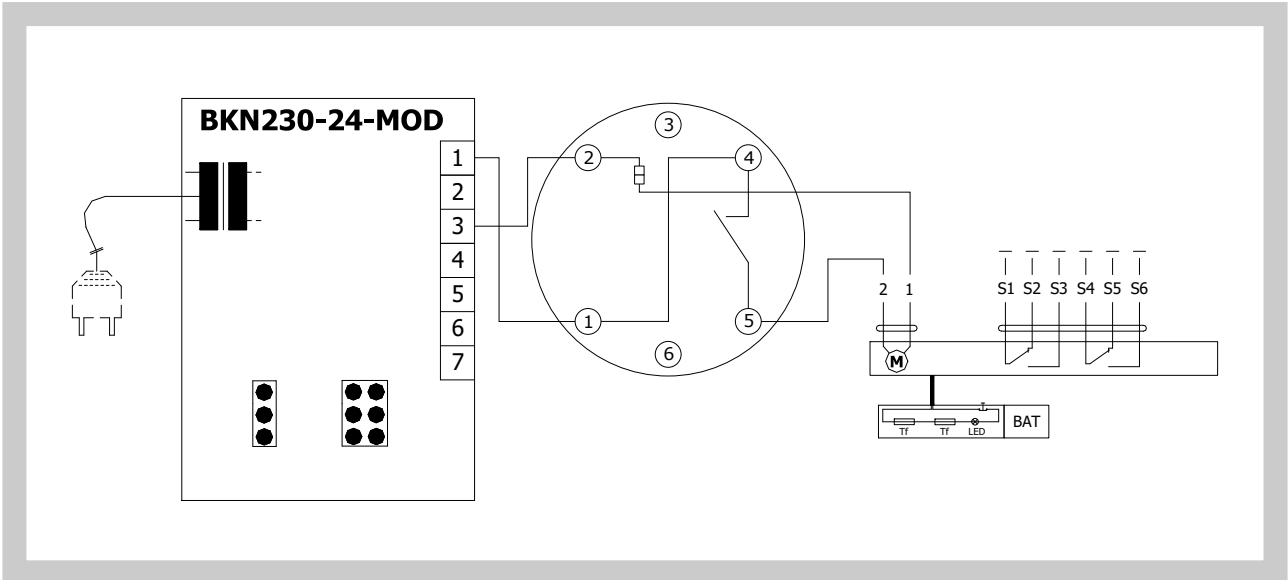
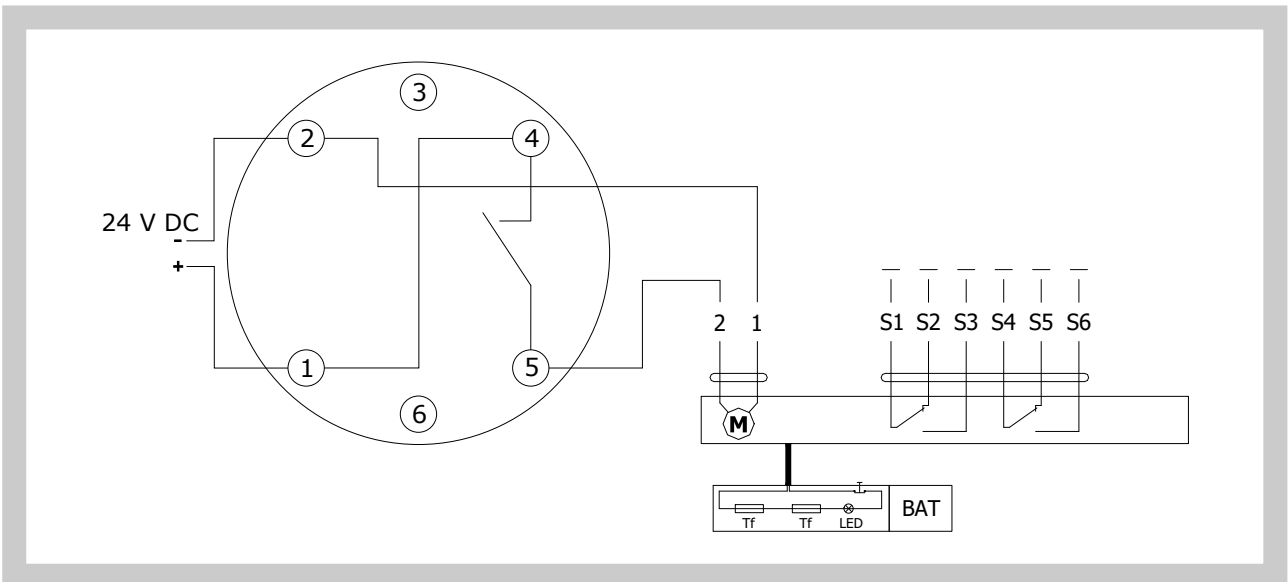

Fig. 15 Design with actuating mechanism BF 24-TN (BFL, BFN 24-T) , with smoke detector ORS 142 K (voltage 24 V DC)



2.3. Design with the communication and supply device

Design .60

Design with the communication and supply device BKN 230-24 and the actuating mechanism BF 24-TN-ST (BFL 24-T, BFN 24-T). It simplifies electrical wiring and interconnection of fire flap valves. It facilitates on site check and enables central control and checks of fire damper by means of a simple 2-conductor wiring.

BKN 230-24 functions as a decentralized network device for supplying the actuating mechanism BF 24-TN-ST (BFL 24-T, BFN 24-T) with a spring back drive on one hand and on the other hand it transmits the signal informing about the flap valve position OPERATION and FAILURE through 2-conductor wiring to the central. Control command SWITCHED ON - SWITCHED OFF from the central through BKN 230-24 goes through the same wiring to the actuating mechanism.

To simplify the connection, the actuating mechanism BF 24-TN-ST (BFL 24-T, BFN 24-T) is equipped with connecting plugs that are inserted directly to BKN 230-24. BKN 230-24 is supplied with a conductor and an EURO plug to be connected to the 230V mains. 2- conductor wiring is connected to BKN 230-24 by means of terminals 6 and 7. If the drive is supposed to be controlled without any signal from the central, it can be switched on by means of a bridge between the terminals 3 and 4. A green LED pilot light on BKN 230-24 is on when voltage is present in the drive (AC 24V).

If the button on BAT is switched on or if the power supply (e.g. by a signal from ELECTRICAL FIRE SIGNALISATION) is disconnected, the damper position will be "FAILURE".

Fig. 16 Design with the communication and supply device BKN 230-24, BKN230-24-C-MP or BKN 230-24-MOD

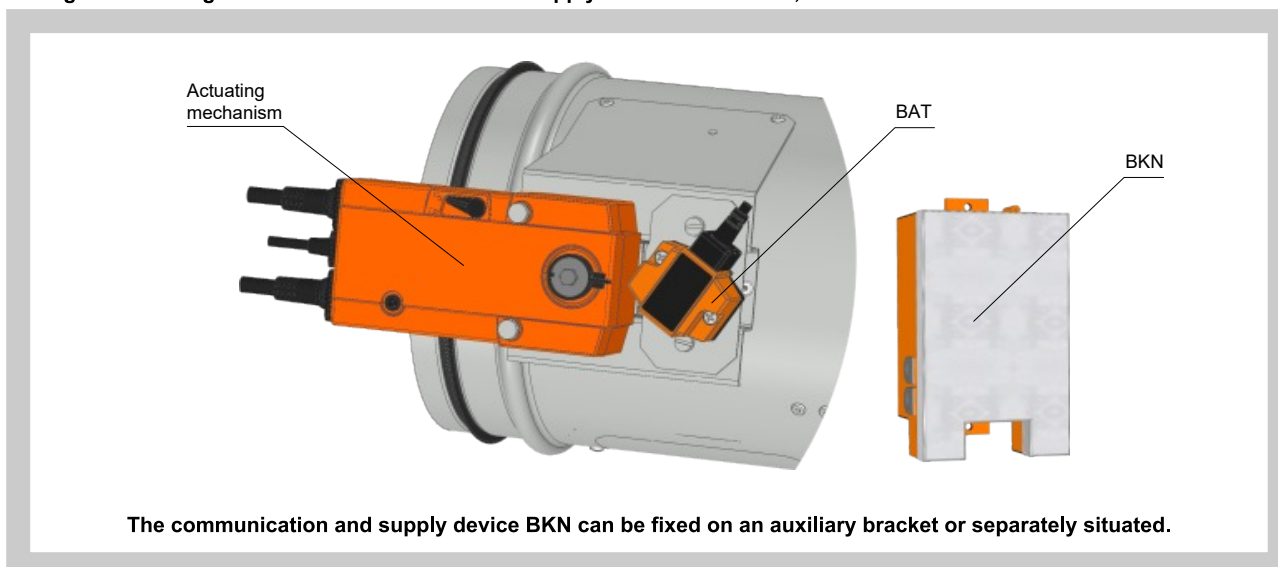

Tab. 2.3.1. Communication and supply device BKN 230-24

Communication and supply device	BKN 230-24
Nominal voltage	AC 230 V 50/60Hz
Power consumption	3,5 W (operating position)
Dimensioning	11 VA (including actuating mechanism with spring return)
Protection Class	II
Degree of protection	IP 40
Ambient temperature	-20°C ... +50°C
Non-operating temperature	-40°C ... +80°C
Connection - net - motor - terminal board	cable 0,9 m with EURO plug type 26 6-pole connector, 3-pole connector screw terminals for cable 2x1,5 mm²

Fig. 17 Communication and supply device BKN 230-24, with act. mechanism BF 24-TN-ST (BFL 24-T-ST, BFN 24-T-ST)

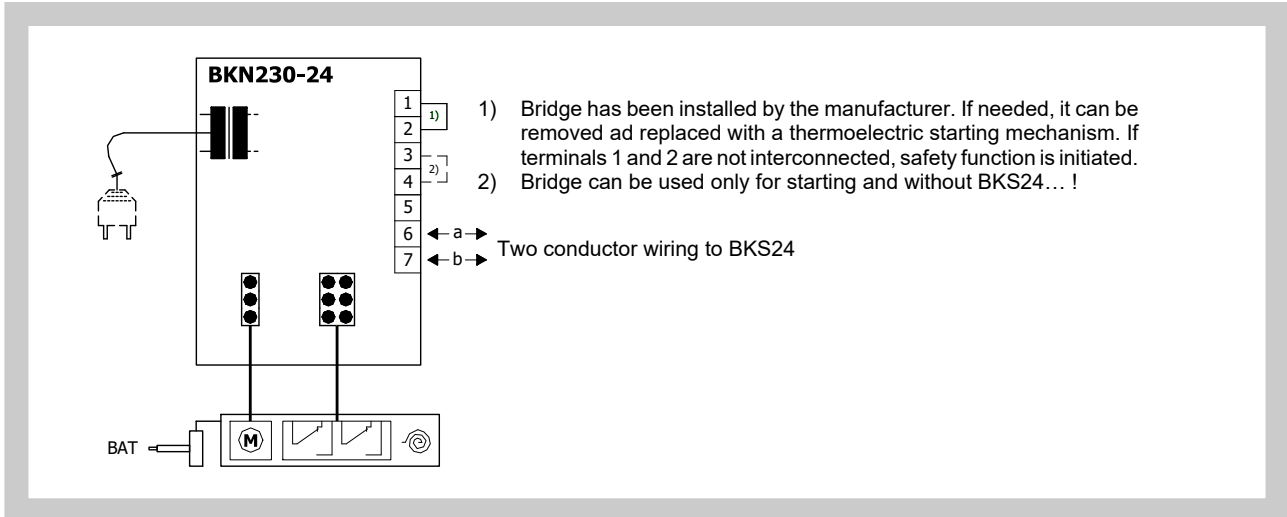

Design .61

Design .61 with communication and supply device can be complemented with smoke detector ORS 142 K. For supply and communication is used BKN 230-24-C-MP, which together with the BF 24TN-ST (BFL 24T-ST, BFN 24T-ST) enables central control and checks of fire damper by means of a simple 2-conductor wiring and it also allows connection to the system via MP-BUS communication. More information in the Belimo catalog.

The smoke detector sensor is not part of the fire damper in the case of dampers in diameters from DN 100 mm to DN 200 mm (including). The smoke sensor is supplied separately.

Tab. 2.3.2. Communication and supply device BKN 230-24-C-MP

Communication and supply device	BKN 230-24-C-MP
Nominal voltage	AC 230 V 50/60Hz
Power consumption	3,5 W (operating position)
Dimensioning	10 VA (including actuating mechanism with spring return)
Protection Class	II
Degree of protection	IP 40
Ambient temperature	-20°C ... +50°C
Non-operating temperature	-40°C ... +80°C
Connection - net - motor - terminal board	cable 0,9 m with EURO plug type 26 6-pole connector, 3-pole connector screw terminals for cable 2x1,5 mm ²

Fig. 18 Communication and supply device BKN 230-24-C-MP

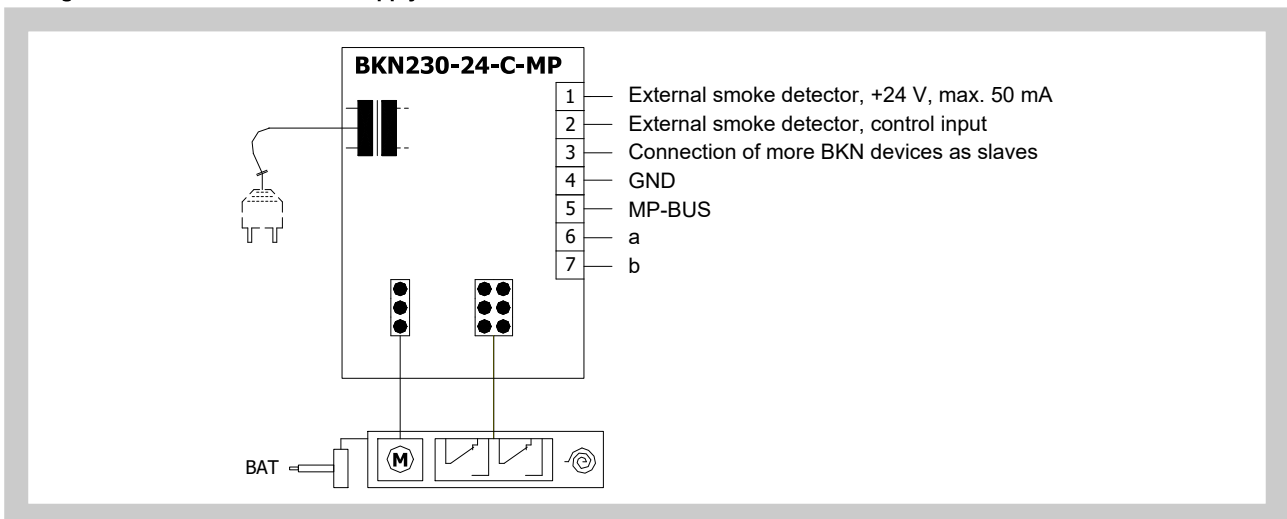
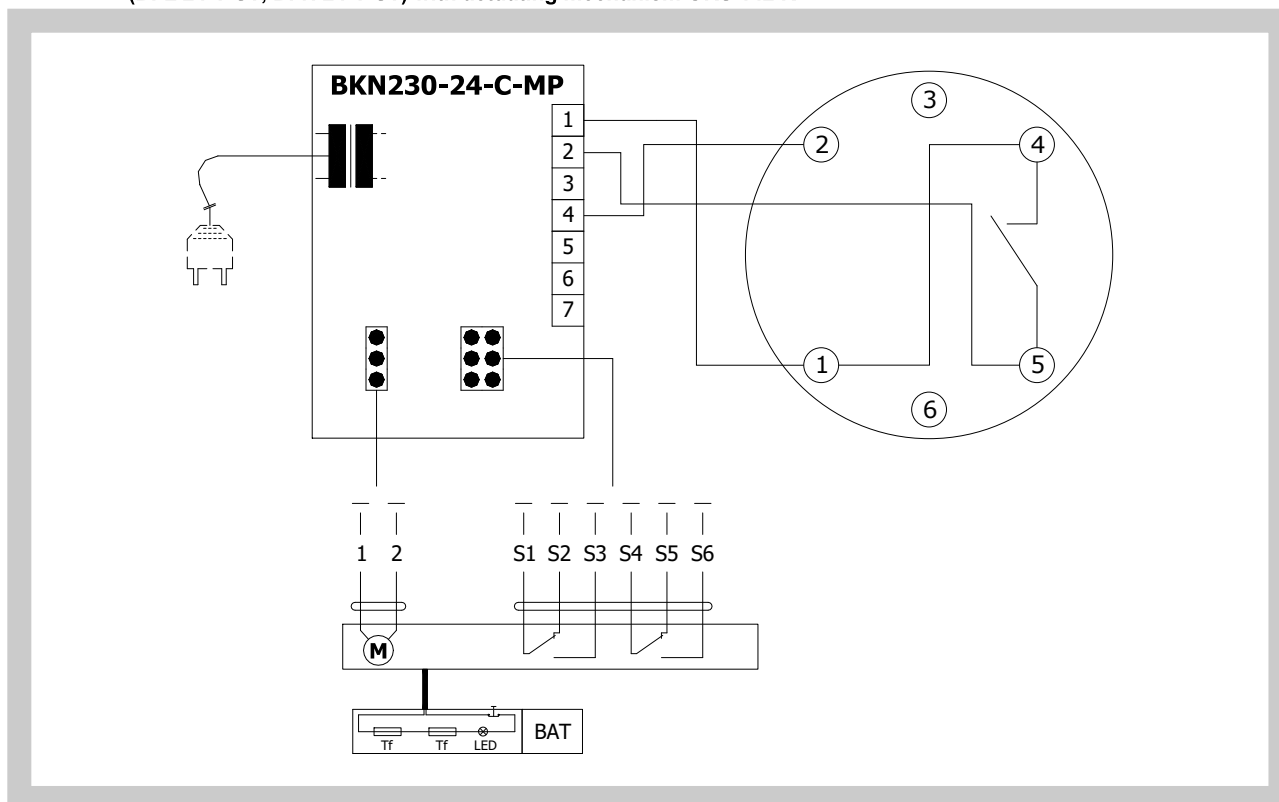

Fig. 19 Design with communication and supply device BKN 230-24-C-MP, with actuating mechanism BF 24-TN-ST (BFL 24-T-ST, BFN 24-T-ST) with actuating mechanism ORS 142 K



Design .63

Design .60 with communication and supply device can be complemented with smoke detector ORS 142 K. For supply and communication is used BKN 230-24-MOD, which is used together with the BF 24TN-ST (BFL 24T-ST, BFN 24T-ST) for communication with control systems using the Modbus RTU or BACnet MS / TP protocol. The wiring of the line is to be carried out in accordance with applicable RS485 regulations. Parameterization of the communication is done using DIL switches. The BKN 230-24-MOD can be installed separately, without a connection to a master control system, in which case the connection bridge between the terminals 1 and 4 must be installed. For more information, see the Belimo catalog.

The smoke detector sensor is not part of the fire damper in the case of dampers in diameters from DN 100 mm to DN 200 mm (including). The smoke sensor is supplied separately.

Tab. 2.3.3. Communication and supply device BKN 230-24-MOD

Communication and supply device	BKN 230-24-MOD
Nominal voltage	AC 230 V 50/60Hz
Power consumption	3 W (operating position)
Dimensioning	14 VA (including actuating mechanism with spring return)
Protection Class	II
Degree of protection	IP 40
Ambient temperature Non-operating temperature	-20°C ... +50°C -40°C ... +80°C
Connection - net - motor - terminal board	cable 0,9 m with EURO plug type 26 6-pole connector, 3-pole connector screw terminals for cable 2x1,5 mm²

Fig. 20 Communication and supply device BKN 230-24-MOD, with act. mechanism BF 24-TN-ST (BFL 24-T-ST, BFN 24-T-ST)

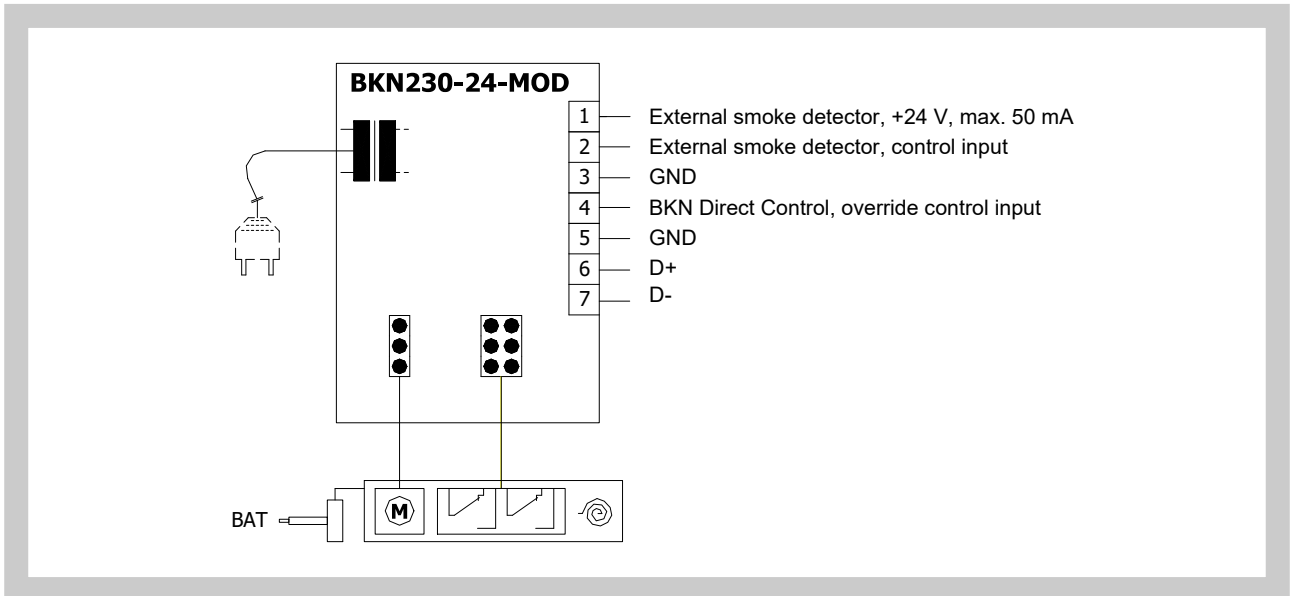
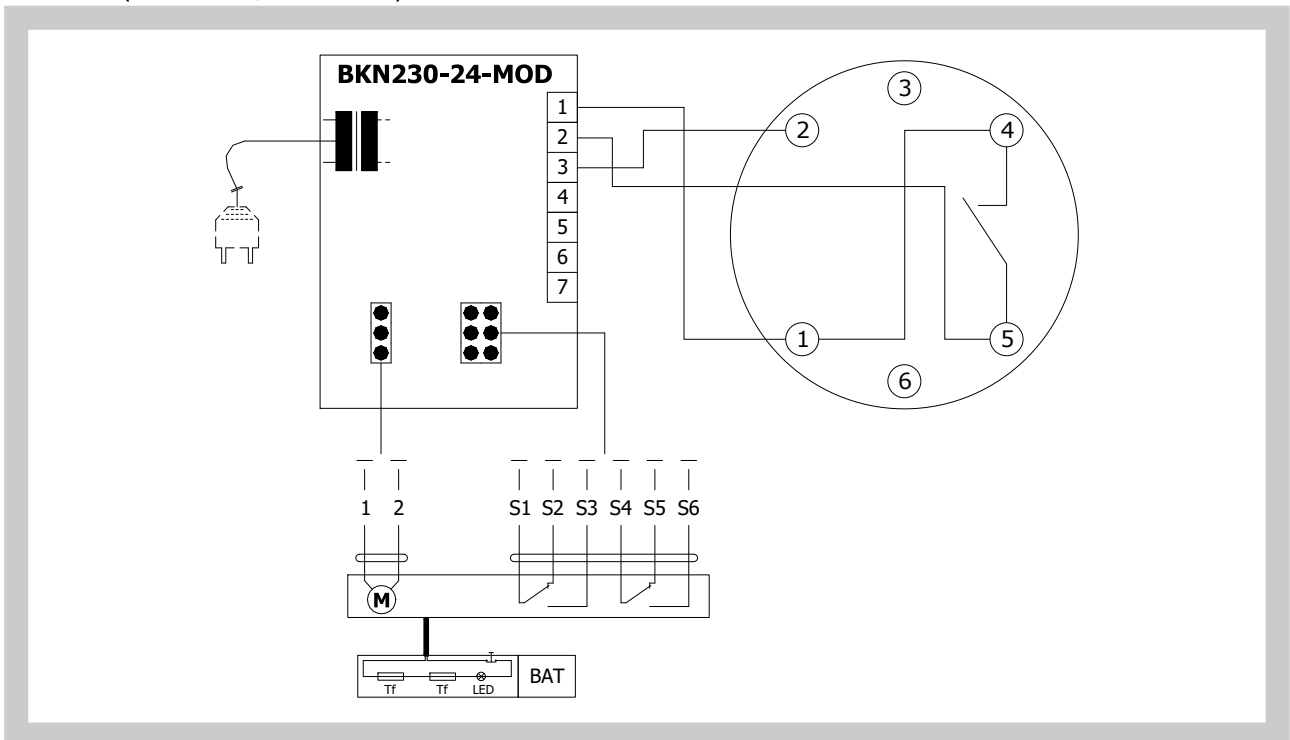

Fig. 21 Design with communication and supply device BKN 230-24-MOD, with actuating mechanism BF 24-TN-ST (BFL 24-T-ST, BFN 24-T-ST) and smoke detector ORS 142 K



Design .62

Design with the communication and supply device BKN 230-24MP and actuating mechanism BF 24TL-TN-ST for connection to MP-Bus. BKN 230-24MP supplies to intelligent actuating mechanisms of fire dampers BF 24TL-TN-ST decentrally needed power supply. In this way can be realize long MP-Bus communications (up to 800 m). Up to 8 Bus nodes can be parallel connected and controlled by Master device (DDC with interface). More information in Belimo catalogue.

Design .64

Design with the communication and supply device BKN 230-24LON and actuating mechanisms of fire dampers BF 24TL-TN-ST for cooperation with control units based on technology LonWorks. BKN 230-24LON complements actuating mechanism for integrated safety function and converts digital protocol MP from actuating mechanism to LonTalk and back. More information in Belimo catalogue.

Fig. 22 Design with communication and supply device BKN 230-24MP or BKN 230-24LON and actuating mechanism BF 24TL-TN-ST

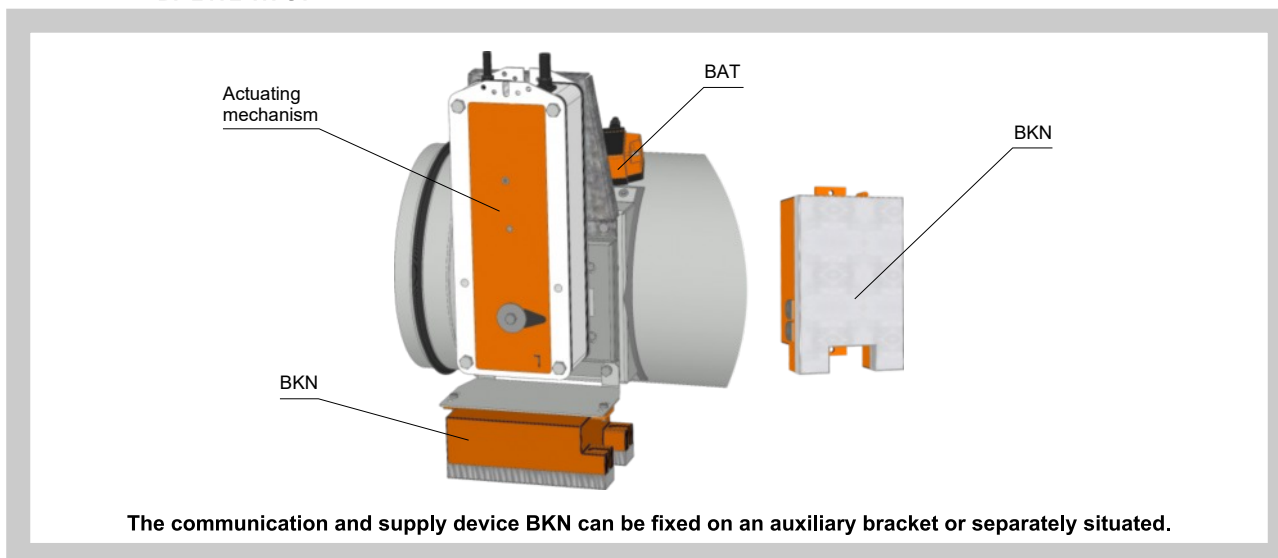

Tab. 2.3.4. Actuating mechanism BELIMO BF 24TL-TN-ST

Actuating mechanism BELIMO	BF 24TL-TN-ST
Nominal voltage	AC 24 V 50/60Hz DC 24 V
Power consumption - motoring - holding	7 W 2 W
Dimensioning	10 VA (I _{max} 8,3 A @ 5 ms)
Protection class	III
Degree of protection	IP 54
Running time - motor - spring return	120 sec ~ 16 sec
Ambient temperature Non-operating temperature	-30°C ... +50°C -40°C ... +50°C
Connection	Connector for BKN 230-24LON and BKN 230-24MP cable 1 m, 4 x 0,75 mm ² halogen-free

Tab. 2.3.5. Communication and supply device BKN 230-24MP

Communication and supply device	BKN 230-24MP
Nominal voltage	AC 230 V 50/60Hz
Power consumption	11 W (including actuator mechanism)
Dimensioning	13 VA (including actuator mechanism)
Protection Class	II
Degree of protection	IP 40
Ambient temperature Non-operating temperature	-30°C ... +50°C -40°C ... +80°C
Connection - net - motor (BF...-Top) - net MP - starting mechanism (variable) - Top-Line PC-Tool (via ZIP-RS232)	cable 1m, with EURO plug 4-pole connector screw terminal 2-pole screw terminal 2-pole 3-pole connector

Fig. 23 Communication and supply device BKN 230-24MP

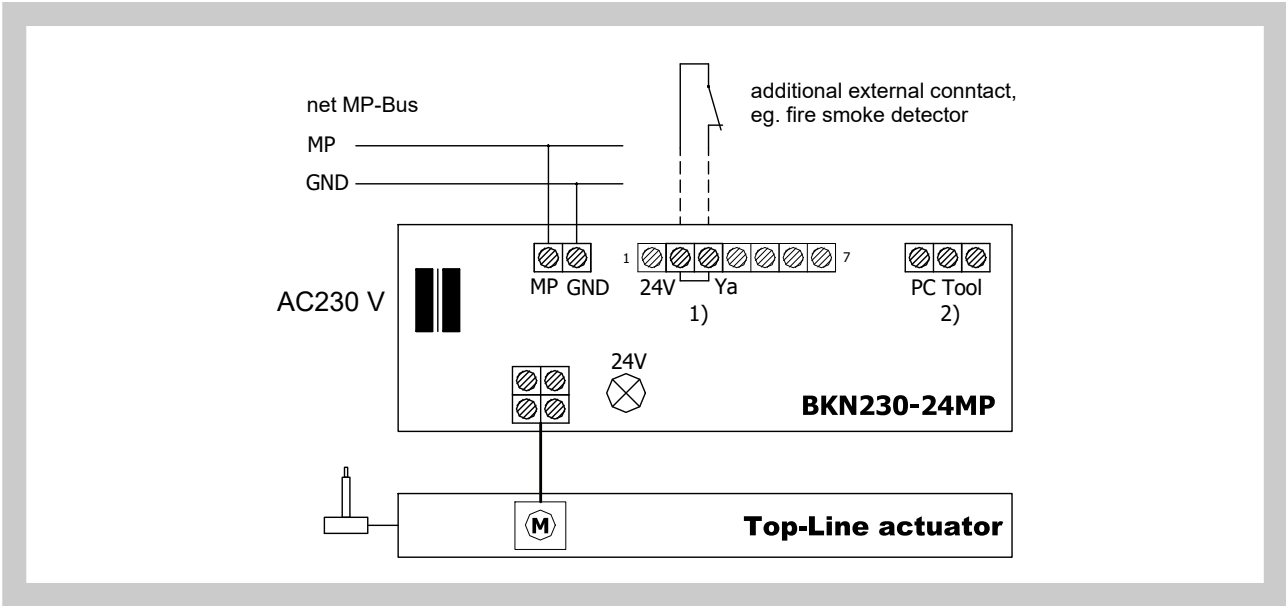

Tab. 2.3.6. Communication and supply device BKN 230-24LON

Communication and supply device	BKN 230-24LON
Nominal voltage	AC 230 V 50/60Hz
Power consumption	14 W (including actuating mechanism)
Dimensioning	16 VA (including actuating mechanism)
Protection Class	II
Degree of protection	IP 40
Ambient temperature	-30°C ... +50°C
Non-operating temperature	-40°C ... +80°C
Connection - net - actuator (BF...-Top) - net LonWorks - starting mechanism (optional) - Top-Line PC-Tool (via ZIP-RS232)	cable 1m, with Euro plug 4-pole connector screw terminal 2-pole screw terminal 2-pole 3-pole connector

Fig. 24 Communication and supply device BKN 230-24LON

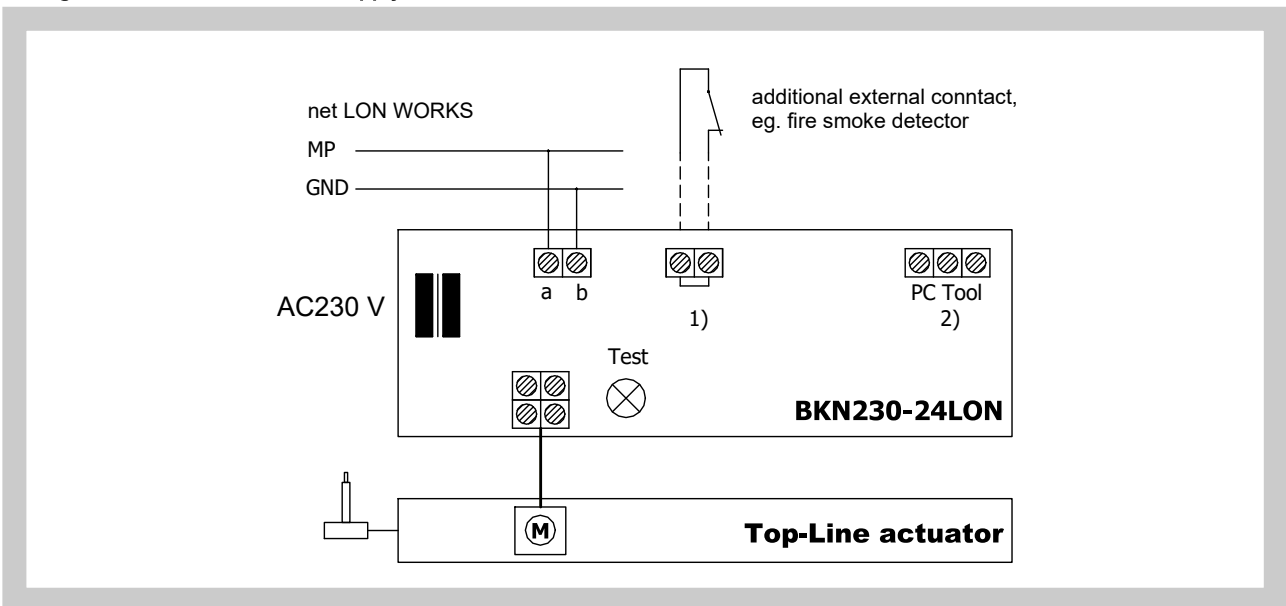

3. Communication and control devices

3.1. BKS 24-1B communication and control device is used for control and checks of fire dampers with the BF 24-TN-ST (BFL 24-T-ST, BFN 24-T-ST) actuating mechanism in conjunction with the BKN 230-24 supply and communication device. BKS 24-1B receives information about the situation of the fire damper through the BKN 230-24 supply and communication device and issues controlling commands. The device is intended for building in into the distribution board. Light diodes on the front side of the device signalise the operating situations of the damper and breakdowns of the whole system. Potentialless auxiliary contacts enable connection to the master control system (signaling of the damper position, failure reports, release of the ventilators etc.). While a flashing green LED pilot light signalises damper blade motion towards the given position, the same pilot light reports reaching the required position when shining constantly. If the flap blade, with respect to the given time, does not reach the required position, then a red LED pilot light starts to flash and at the same time, the failure contact is active. Once the damper blade reaches the given position, this contact is deactivated. The LED pilot light keeps flashing unless the failure is unblocked by means of the RESET button. Except for reporting failures, other three auxiliary contacts are available. Contacts showing operating and failure position of the damper are active when the damper is in the given position. Function check can be done by pressing and holding the button "RESET/TEST" for longer time. While holding the button, the damper blade moves in the direction of the failure position. Fault function is indicated by the LED pilot light. BKS 24-1B can be connected by means of ZSO-11 11 pole connector for DIN 35 mm panel.

Fig. 25 Communication and control device BKS 24-1B

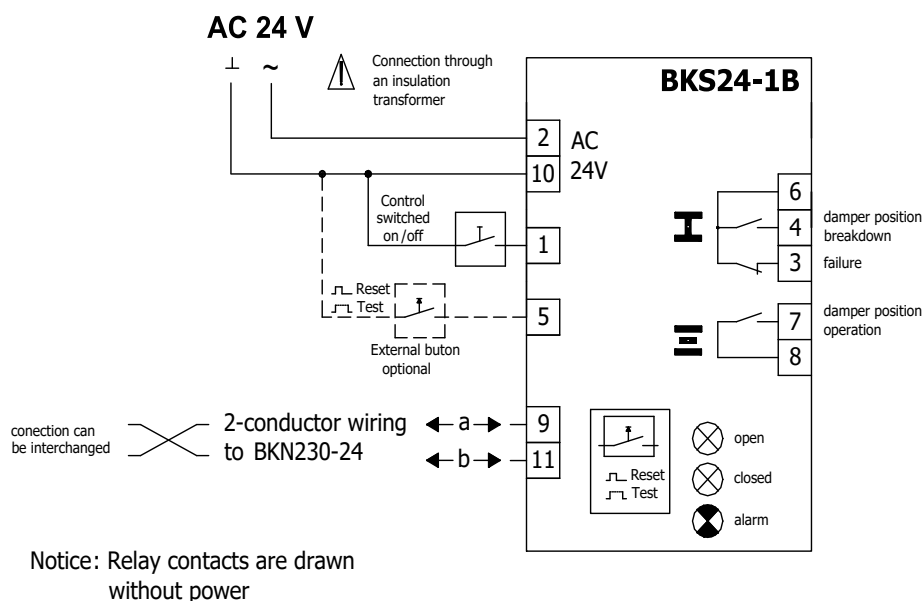

light diodes			contacts	Description
open	closed	alarm	state	Cause/Course
⊗ closed	⊗ closed	⊙ closed	[6] — [3]	Power supply AC 24V not available
⊗ open	⊗ open	⊗ open	[6] — [3]	Check test cca 35sec , starting with switching AC 24 on or pressing «Reset/Test» button
⊗ closed	⊗ closed	⊗ flashing	[6] — [3]	Current failure , possible cause: • short circuit or interruption of 2-conductor wiring or damper failure (at BKN..) • Power supply AC 230V missing • defective thermoelectrical starting • smoke detector activated • exceeded operation time • damper blocked
⊗ closed	⊗ closed	⊗ open	[6] — [3]	Failure saved in memory • Fault in system signalled, system check should be done
⊗ closed	⊗ flashing	⊙ closed	[6] — [4]	Damper (drive) turning into the direction of breakdown position
⊗ closed	⊗ open	⊙ closed	[6] — [4]	Damper (drive) in breakdown position I
⊗ flashing	⊗ closed	⊙ closed	[6] — [7]	Damper (drive) turning into the direction of operating position
⊗ open	⊗ closed	⊙ closed	[6] — [7]	Damper (drive) in operating position II

Tab. 3.1.1. Communication and control device BKS 24-1B



Communication and control device	BKS 24-1B
Nominal voltage	AC 24 V 50/60Hz
Power consumption	2,5 W (operating position)
Dimensioning	5 VA
Protection Class	III
Degree of protection	IP 30
Ambient temperature	0 ... +50°C
Connection	11-pole connector ZSO-11, it is not part of BKS24-1B, ZSO-11 is 11-pole screw terminal 11 x 1,5 mm ²

3.2. BKS 24-9A communication and control device is used for group control and checks of 1 to 9 fire dampers with the actuating mechanism BF 24-TN-ST (BFL 24-T-ST, BFN 24-T-ST) in connection with the supply and communication device BKN 230-24. Signalisation of the damper position is individual; the damper can be controlled and tested only as a group. BKS 24-9A is intended for use in the distribution board and displays the operation situations and failure reports of the connected fire dampers. It is possible to signalise functions such as the damper position and failure reports or to transmit them further to the system by means of integrated auxiliary switches. BKS 24-9A receives signals from BKN 230-24 through the two-conductor wiring and issues control commands. Proper damper operation is indicated by two light LED diodes:

Control ON = position OPERATION
 Control OFF = position FAILURE

If the fire damper do not reach the given position in time tolerable for displacing, the appropriate light diode FAILURE starts to flash and K1 contact is opened (current failure). In case that the faulty damper finally reaches its given position, K1 is closed and the failure report light shines (the failure is saved in memory). K2 - the auxiliary contact - is used for signaling of the flap position to the master device. Function of this auxiliary contact can be programmed through the terminal 14 according to the Tab. 3.2.1.

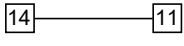
Tab. 3.2.1. BKS 24 -9A contacts K1 and K2

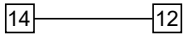
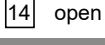
Function contact K1		Programming K2 Auxiliary Contact		
situation	state	function	interconnection	state
current failure	15  16	K2 contact is on if all the flaps are open		17  18
no failure	15  16	K2 contact is on if the flap No. 1 is open		
		K2 contact is on if all the flaps are closed		

Function check can be done in the position OPERATION by means of pushing the TEST button. While the button is pushed, the flap blade is turning into the position FAILURE. Fault function is indicated by a report "FAILURE". Assembly and connection BKS 24 - 9A can be made by DIN 35 mm panel. It is connected by two 9-pole plug-in connectors.

Fig. 26 Communication and control device BKS 24-9A

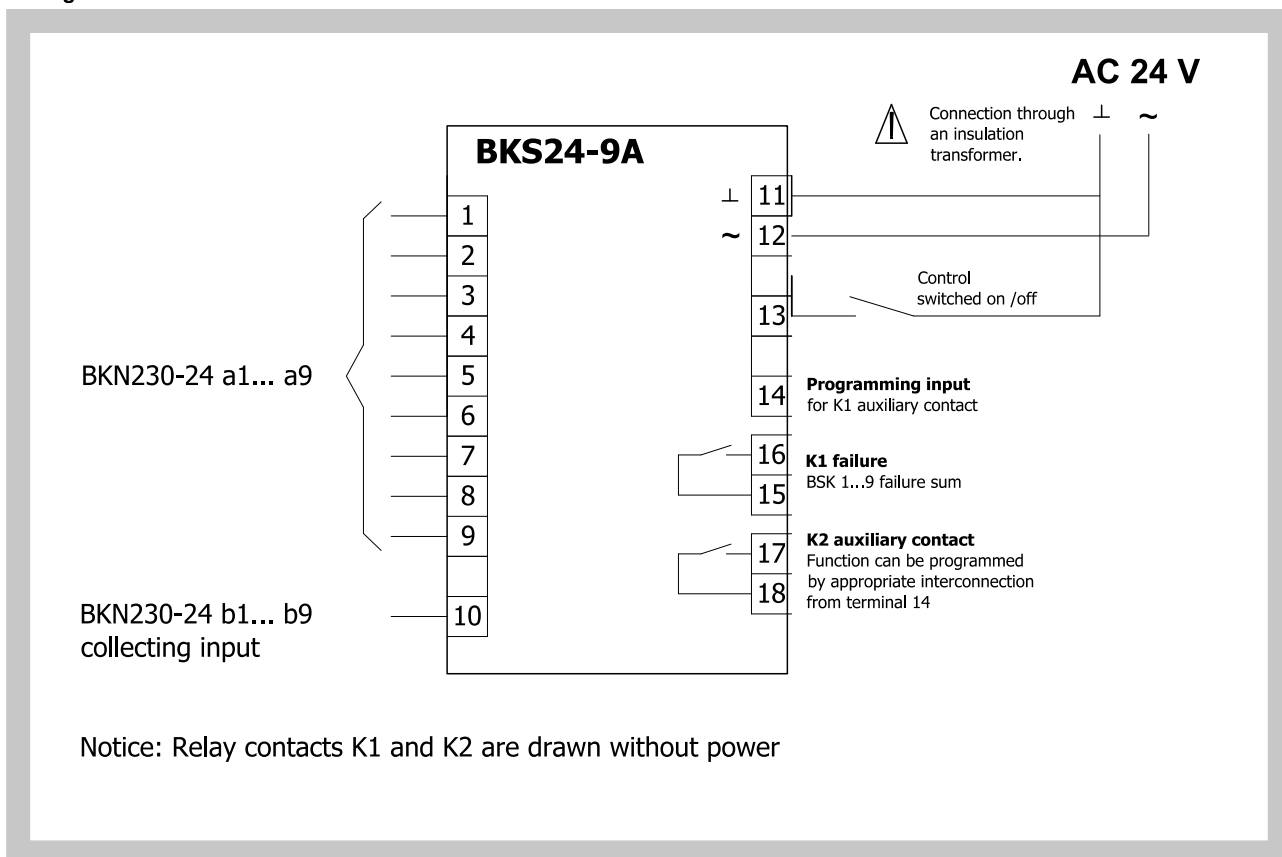

Tab. 3.2.2. Communication and control device BKS 24-9A

Communication and control device	BKS 24-9A
Nominal voltage	AC 24 V 50/60Hz
Power consumption	3,5 W
Dimensioning	5,5 VA
Protection Class	III
Degree of protection	IP 30
Ambient temperature	0 ... +50°C
Connection	terminal 2 x 1,5 mm ²

4. Dimensions, weights and effective area

4.1. Dimensions, weights and effective area

Tab. 4.1.1. Dimensions, weights and effective area

Nominal size ØD [mm]	a [mm]	c [mm]	Weight *		Effective area S _{ef} [m ²]	Leaf th. [mm]	Actuating mechani.	Mechan. control
			design					
			manual [kg]	act. mech. [kg]				
100	-	-	2,9	3,1	0,0031	20	BFL	M1
125	-	-	3,2	3,4	0,0062	20	BFL	M1
140	-	-	3,3	3,5	0,0085	20	BFL	M1
150	-	-	3,5	3,7	0,0103	20	BFL	M1
160	-	-	3,6	3,8	0,0123	20	BFL	M1
180	-	-	4,0	4,2	0,0166	20	BFL	M1
200	-	-	4,3	4,5	0,0215	20	BFL	M1
225	-	-	4,8	5,0	0,0275	25	BFL	M1
250	-	9	5,1	5,3	0,0354	25	BFL	M2
280	-	24	5,7	5,9	0,0462	25	BFL	M2
315	-	42	6,5	6,7	0,0606	25	BFL	M2
355	-	62	8,2	8,3	0,0776	30	BFL	M2
400	-	84	9,3	9,4	0,1015	30	BFL	M2
450	-	109	10,4	10,8	0,1318	30	BFN	M3
500	-	134	11,7	12,1	0,1661	30	BFN	M3
560	-	164	13,4	13,8	0,2123	30	BFN	M3
630	19	199	15,5	17,7	0,2735	30	BF	M4
710	59	239	27,0	29,2	0,3446	40	BF	M4
800	104	284	32,4	34,6	0,4448	40	BF	M5

* The weight of the anchor is 0,04 kg.

Fig. 27 SPIRO design with mechanical control

DN 100 - DN 315

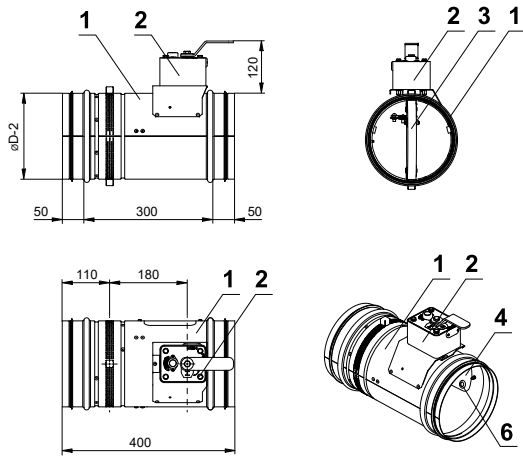

DN 350 - DN 500

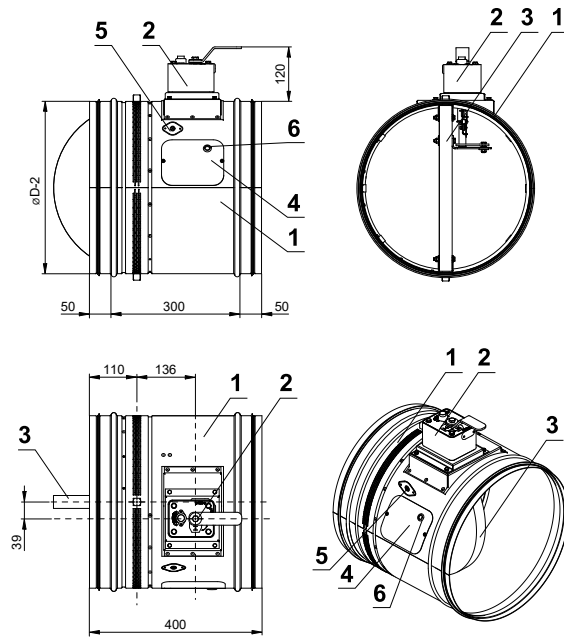

DN 560 - DN 800

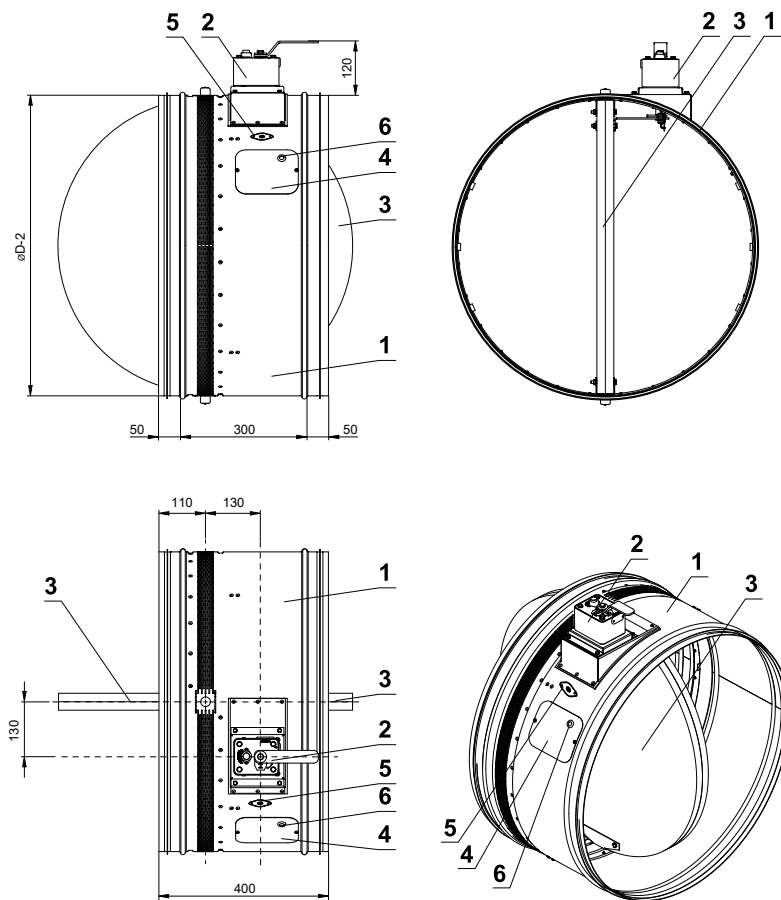

Position:

- 1 Damper casing
- 2 Mechanics
- 3 Damper blade
- 4 Inspection hole covering
- 5 Sensor sticker
- 6 Hole for camera

Fig. 28 FLANGE design with mechanical control

DN 100 - DN 315

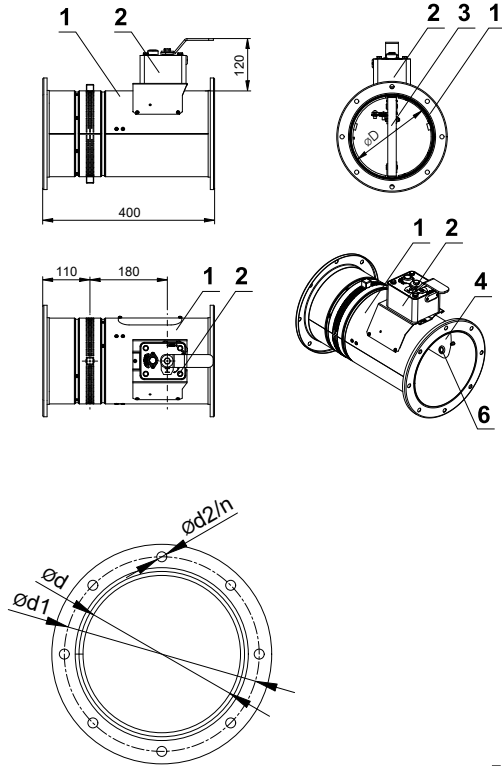

DN 350 - DN 500

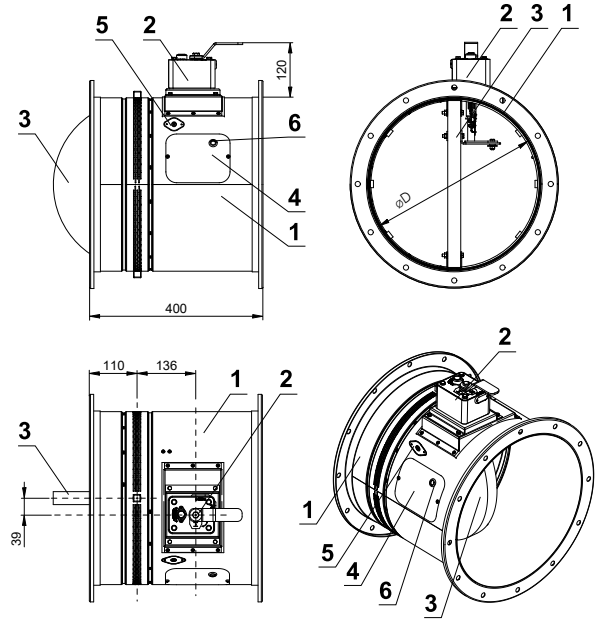

DN 560 - DN 800

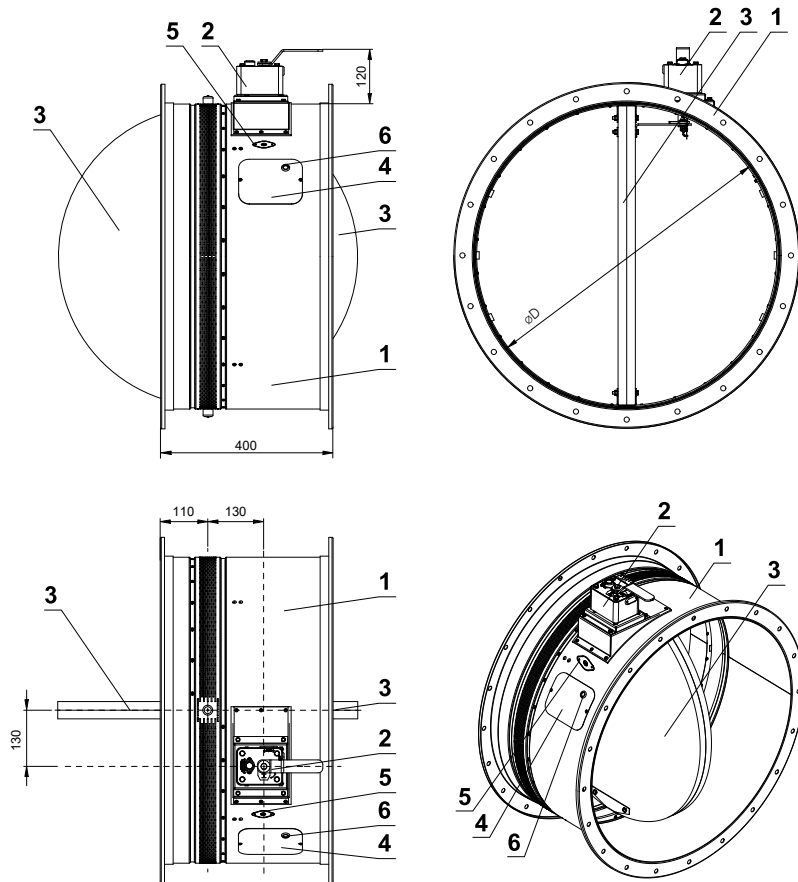

ød [mm]	ød1 [mm]	ød2 [mm]	n number of holes in the flange
100	130	10	4
125	155	10	8
160	195	10	8
180	215	10	8
200	235	10	8
225	260	10	8
250	285	10	8
280	315	10	8
315	350	10	12
355	390	10	12
400	445	12	12
450	495	12	12
500	545	12	16
560	605	12	16
630	680	12	16
710	760	12	20
800	860	12	20

Position:

- 1 Damper casing
- 2 Mechanics
- 3 Damper blade
- 4 Inspection hole covering
- 5 Sensor sticker
- 6 Hole for camera

Fig. 29 Design SPIRO with actuating mechanism

DN 100 - DN 315

The actuator cannot be rotated

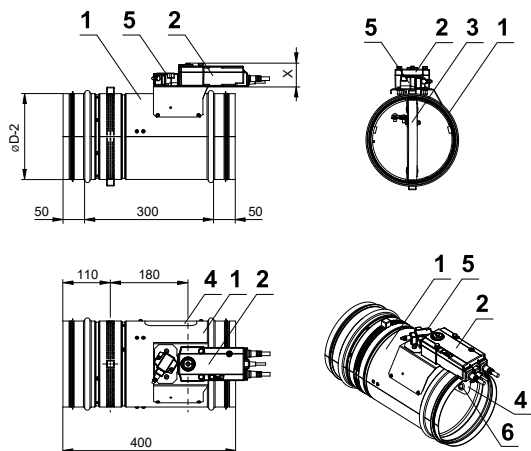

DN 350 - DN 500

The actuator can be rotated 90°

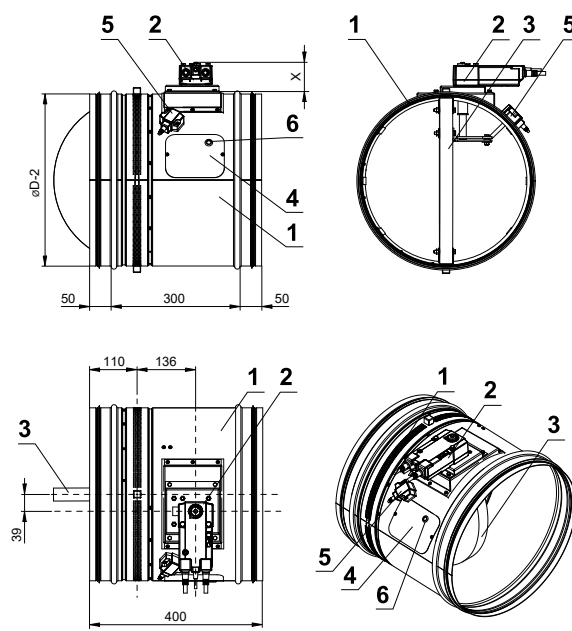

DN 560 - DN 800

The actuator can be rotated 90°

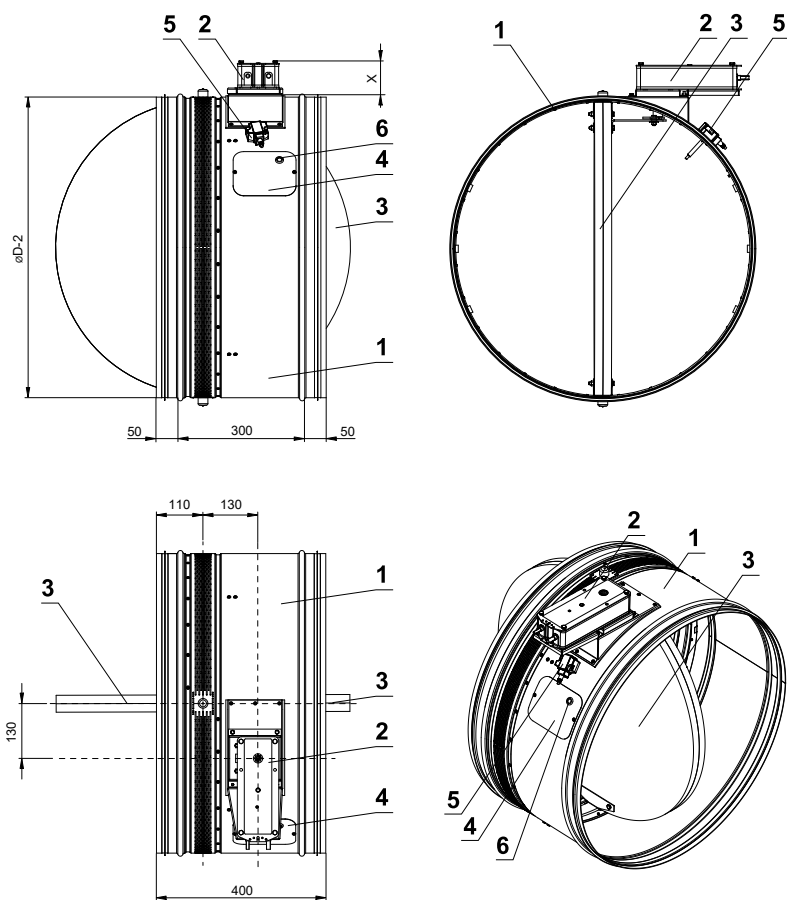

X=53 mm (BFL) *
 X=72 mm (BFN) *
 X=78 mm (BF) *

Position:

- 1 Damper casing
- 2 Actuating mechanism
- 3 Damper blade
- 4 Inspection hole covering
- 5 BAT thermoelectrical starting mechanism
- 6 Hole for camera

* Assignment of actuating mechanisms to individual sizes Tab. 4.1.1.

Fig. 30 Design FLANGE with actuating mechanism

DN 100 - DN 315

The actuator cannot be rotated

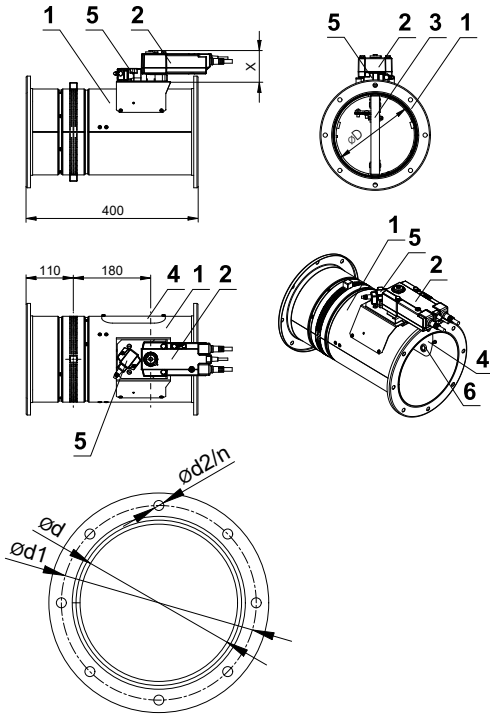

DN 350 - DN 500

The actuator cannot be rotated

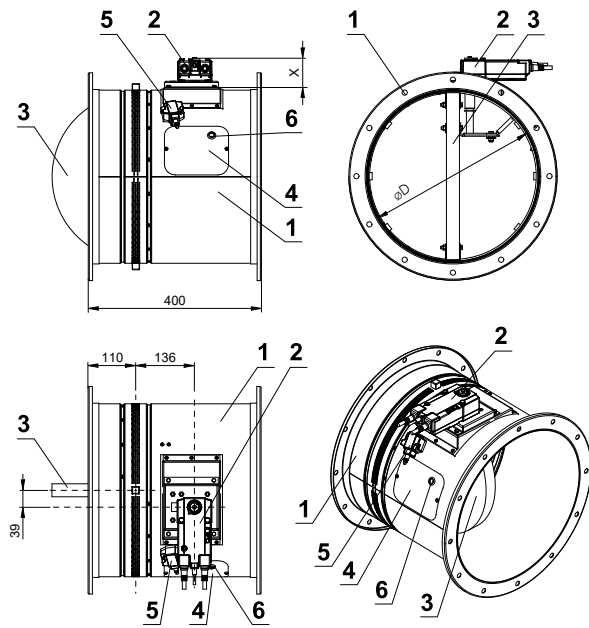

DN 560 - DN 800

The actuator cannot be rotated

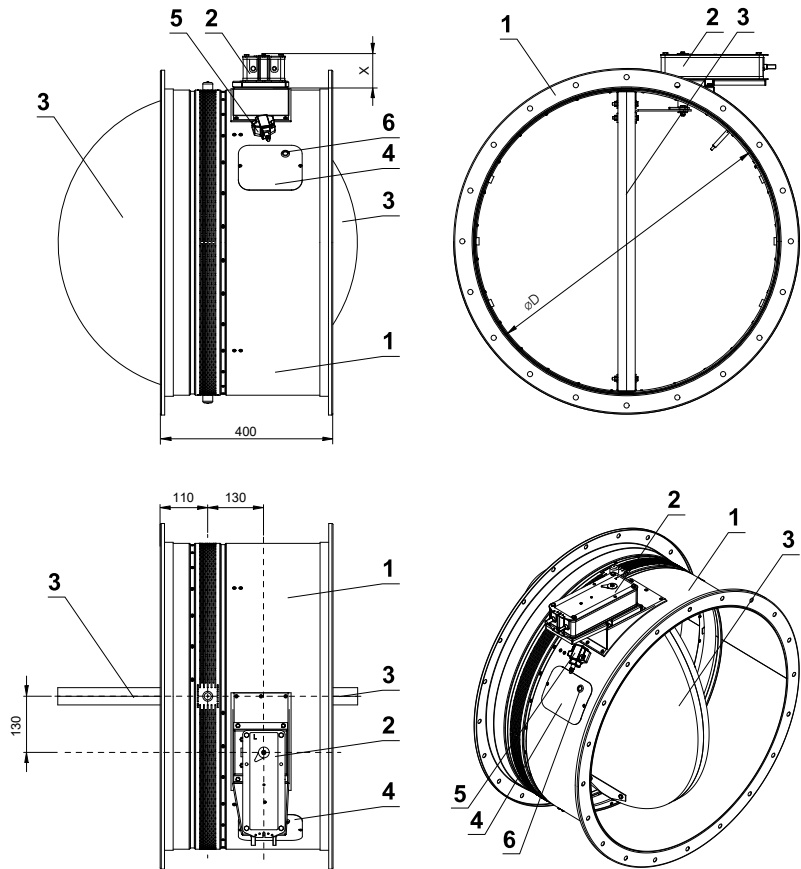

$\varnothing d$ [mm]	$\varnothing d1$ [mm]	$\varnothing d2$ [mm]	n number of holes in the flange
100	130	10	4
125	155	10	8
160	195	10	8
180	215	10	8
200	235	10	8
225	260	10	8
250	285	10	8
280	315	10	8
315	350	10	12
355	390	10	12
400	445	12	12
450	495	12	12
500	545	12	16
560	605	12	16
630	680	12	16
710	760	12	20
800	860	12	20

X=70 mm (BFL - DN 100 ÷ DN 315) *
 X=53 mm (BFL - DN 355 ÷ DN 400) *
 X=72 mm (BFN) *
 X=78 mm (BF) *

Position:

- 1 Damper casing
- 2 Actuating mechanism
- 3 Damper blade
- 4 Inspection hole covering
- 5 BAT thermoelectrical starting mechanism
- 6 Hole for camera

* Assignment of actuating mechanisms to individual sizes Tab. 4.1.1.

Fig. 31 Fire damper with installation holders

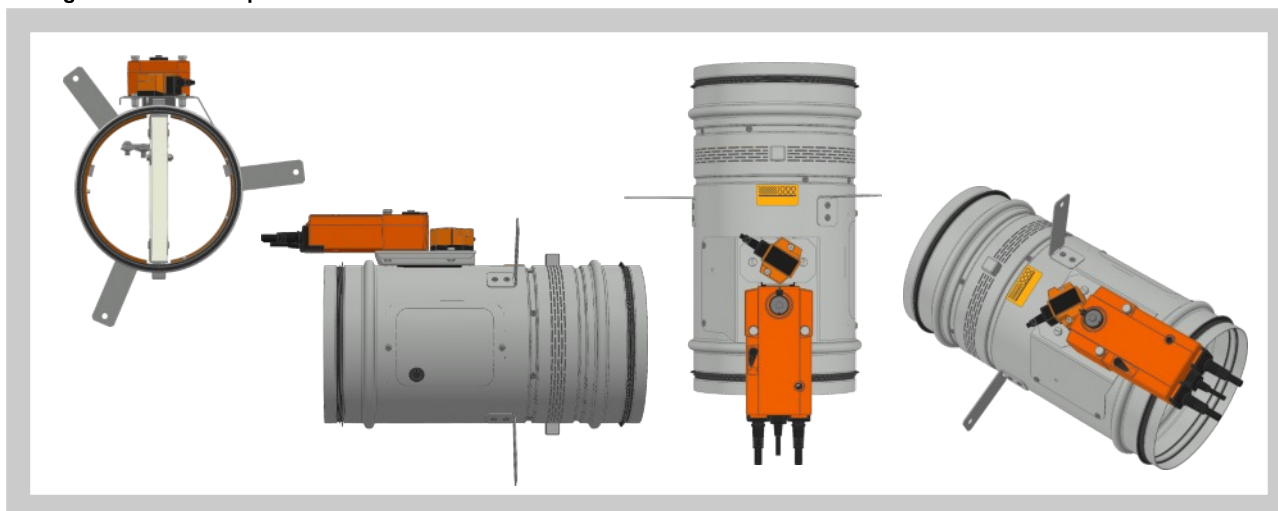

4.2. Blades overlaps

Tab. 4.2.1 Blades overlaps

Blades overlaps		Dimension	Overlaps
DAMPERS SPIRO Fig. 32	Act. mechanism side	"a"	Tab. 4.1.1
	Side without act. mechanism	"c"	
DAMPERS FLANGE Fig. 33	Act. mechanism side	"a"	
	Side without act. mechanism	"c"	

These values has to be respected when projecting related air-conditioning ducts.

Fig. 32 Blade overlaps - damper SPIRO

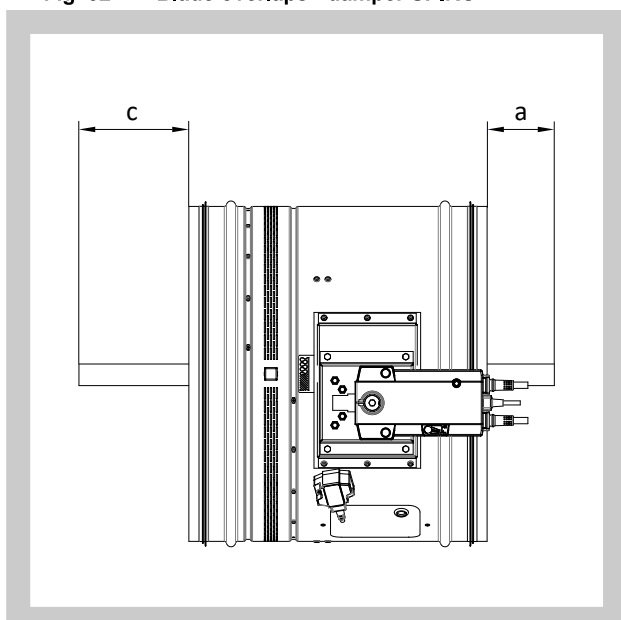
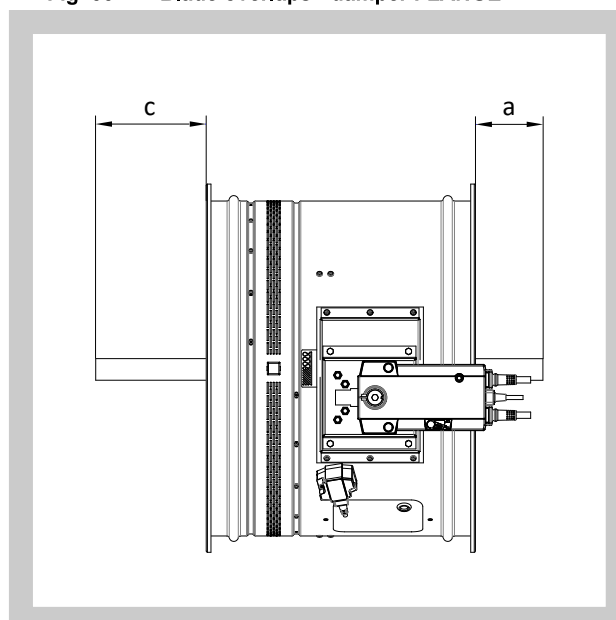

Fig. 33 Blade overlaps - damper FLANGE



4.3. For the design .60 (with BKN supply and communication device) add to weight of the damper with an actuating mechanism (from the Tab 4.4.1.) the weight of BKN (0.5 kg).

4.4. Dimensions of damper connecting flanges are in accordance with EN 12 0505. In case of damper installation into SPIRO duct, round dampers are supplied without the flanges so as it is possible to connect them with external joints (it is necessary to specify this requirement in the order).

5. Placement and Assembly

5.1. The fire dampers are suitable for installation in arbitrary position in vertical and horizontal passages of fire separating structures. The damper assembly procedures must be done so that all load transfer from the fire separating constructions to the damper body is absolutely excluded. The back-to-back air-conditioning piping must be suspended or supported so that all load transfer from the back-to-back piping to the damper flanges is absolutely excluded. The gap between the installed damper and the building structure must be perfectly filled with approved material all over its volume.

To provide the necessary space for access to the control device, all other items must be situated at least 350 mm from the control parts of the damper. At least one inspection hole must be accessible.

The damper must be installed so that the damper blade (in closed position) is situated in the fire separating structure - marked by the label BUILD-IN EDGE on the damper body. If such solution is not possible, the piping between the fire separating structure and the damper blade must be protected according to the certified installation method, see [Section 6](#).

During the installation and plastering process, the control mechanism must be protected (covered) against damage and pollution. The damper body should not be deformed during bricking in. Once the damper is built in, the damper blade should not grind on the damper body during opening or closing.

The distance between the fire damper and the structure (wall, ceiling) must be 75 mm at the minimum. If two or more dampers are to be installed in one fire separating structure, the distance between adjacent dampers must be 200 mm at the minimum, according to EN 1366-2 paragraph 13.5. For admissible exceptions see [Section 6](#).

Fig. 34 The distance between the fire damper and the construction

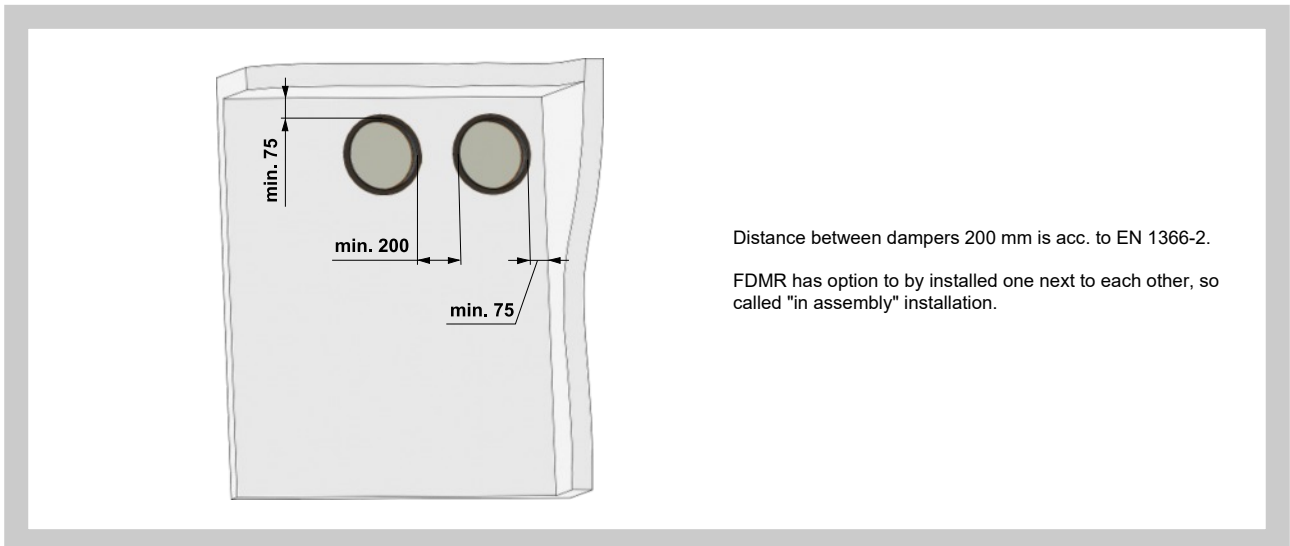
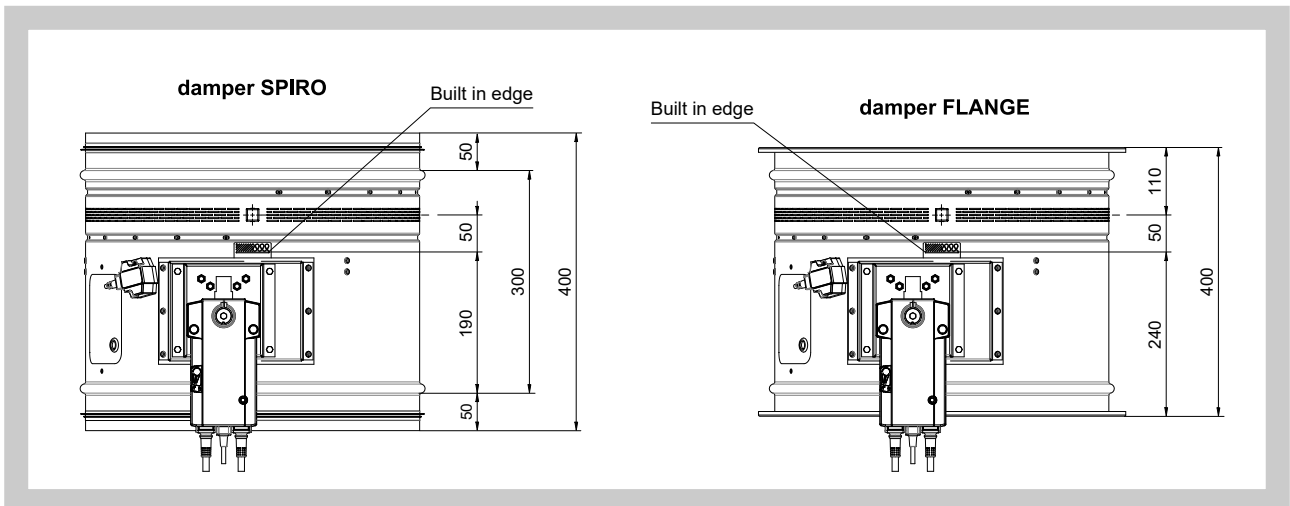

Fig. 35 Built in edge



"Wall edge sticker" indicates the recommended edge of installation of fire damper into the fire partition structure (wall). The damper must be installed so that the entire damper blade - in the closed position - is located inside the fire separating structure (wall) and at the same time the control mechanism and inspection openings are freely accessible.

Fig. 36 Installation opening

Installation opening - round damper

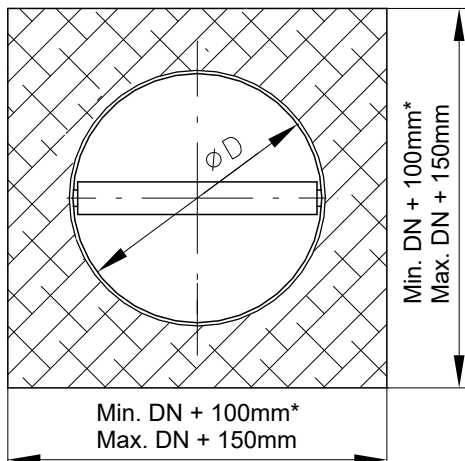

Installation opening - round damper

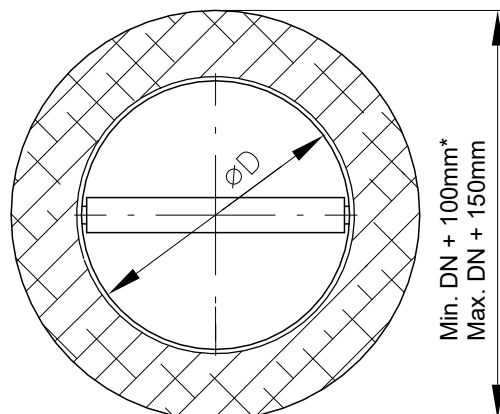

Installation opening - round damper Weichschott system

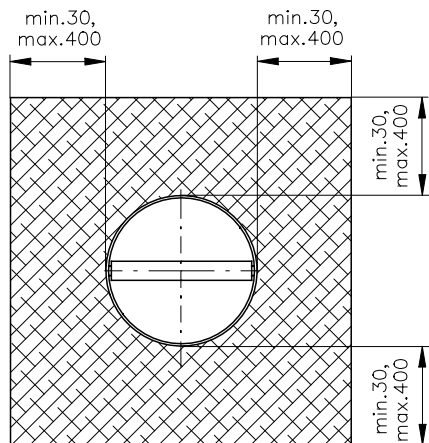

* Installation opening can be less than DN + 100mm - If the fire stopping material can be installed correctly.

Notice:
Damper with flanges - see Fig. 28, due to its mounting with regard to the flange height.

5.2. Examples of fire damper installing

The fire damper can be integrated into a solid wall construction made e.g. of normal concrete/ masonry, porous concrete with minimum thickness 100 mm or into solid ceiling construction made e.g. of normal concrete with minimum thickness 110 mm or porous concrete with minimum thickness 125 mm.

The fire damper can be integrated into a gypsum wall construction with fire classification EI 120 or EI 90.

6 Statement of installations

6.1. Installation method list

Tab. 6.1.1. Installation method list

Fire separating constr.	Wall/Ceiling	Installation	Fire resist.	Page
	Min. thickness [mm]			
Solid wall construction	100	Mortar or gypsum	EIS 120 - 500 Pa	28
	100	Stuffing box and fire protection mastic	EIS 60	28
	100	Stuffing box with fire protection mastic and coating	EIS 90	29
	100	Fire protection foam with stucco plaster	EIS 60 EIS 45 EIS 30	29
	100	Battery - mortar or gypsum	EIS 90	30
	100	Installation next to wall - mortar or gypsum and mineral wool	EIS 90	31
	100	Installation next to wall - mortar or gypsum	EIS 90	32
	100	Installation next to wall - installation frame R1, R2, R3, R4, R5 and mineral wool	EIS 90	32, 33
	100	Stuffing box with fire protection mastic and cement lime plate	EIS 90	34
	100	Installation frame R1, R2, R3, R4, R5	EIS 90	35
	100	Weichschott / Ablative Coated Batt	EIS 90	36
	100	Battery - installation frame R1	EIS 90	37
	Outside solid wall construction	100	Mineral wool - mortar or gypsum - ISOVER ULTIMATE PROTECT	EIS 90 EIS 60
100		Mineral wool - stuffing box and fire protection mastic - ISOVER ULTIMATE PROTECT	EIS 90 EIS 60	38
100		Mineral wool, stuffing box, fire protection mastic and cement lime plate	EIS 90	39
100		Insulating with cement lime plates - installation frame R6	EIS 90	40
Gypsum wall construction	100	Mortar or gypsum	EIS 120 - 500 Pa	41
	100	Stuffing box and fire protection mastic	EIS 60	41
	100	Stuffing box with fire protection mastic and coating	EIS 90	42
	100	Fire protection foam with stucco plaster	EIS 60 EIS 45 EIS 30	42
	100	Battery - mortar or gypsum	EIS 90	43
	100	Installation next to wall - mortar or gypsum and mineral wool	EIS 90	44
	100	Installation next to wall - mortar or gypsum	EIS 90	45
	100	Installation next to wall - installation frame R1, R2, R5 and mineral wool	EIS 90	45, 46
	100	Stuffing box with fire protection mastic and cement lime plate	EIS 90	47
	100	Installation frame R1, R2, R3, R4, R5	EIS 90	48
	100	Weichschott / Ablative Coated Batt	EIS 90	49
	100	Battery - installation frame R1	EIS 90	50
	100	Flexible ceiling - installation frame R7	EIS 90	51
	110	Wooden construction (beams 60x60mm) - Weichschott / Ablative Coated Batt	EIS 90	51
	Outside gypsum wall construction	100	Mineral wool - mortar or gypsum - ISOVER ULTIMATE PROTECT	EIS 90 EIS 60
100		Mineral wool - stuffing box and fire protection mastic - ISOVER ULTIMATE PROTECT	EIS 90 EIS 60	52
100		Mineral wool, stuffing box, fire protection mastic and cement lime plate	EIS 90	53
Solid ceiling construction	110 - Concrete 125 - Aerated concrete	Mortar or gypsum	EIS 120 - 500 Pa	54
		Stuffing box and fire protection mastic	EIS 60	54
		Battery - mortar or gypsum	EIS 90	55
		Stuffing box with fire protection mastic and cement lime plate	EIS 90	56
		Stuffing box with fire protection mastic and coating	EIS 90	57
		Installation frame R1, R2, R3, R4, R5	EIS 90	58
		Weichschott / Ablative Coated Batt	EIS 90	59
		Battery - Installation frame R2	EIS 90	60
Outside solid ceiling construction	110 - Concrete 125 - Aerated concrete	Mineral wool - mortar or gypsum - ISOVER ULTIMATE PROTECT	EIS 90 EIS 60	61
		Mineral wool - mortar or gypsum	EIS 90	62
		Concrete	EIS 90	63
		Concrete with installation frame R5	EIS 90	63
		Insulating with cement lime plates - installation frame R6	EIS 90	64
Sandwich wall construction	100	Stuffing box and fire protection mastic, coating and cement lime plate	EIS 90	65
Thin shaft wall	-	Mortar or gypsum	EIS 90	67
	-	Installation frame R1	EIS 90	68

6.2. Installation in solid wall construction

Fig. 37 Solid wall construction - mortar or gypsum

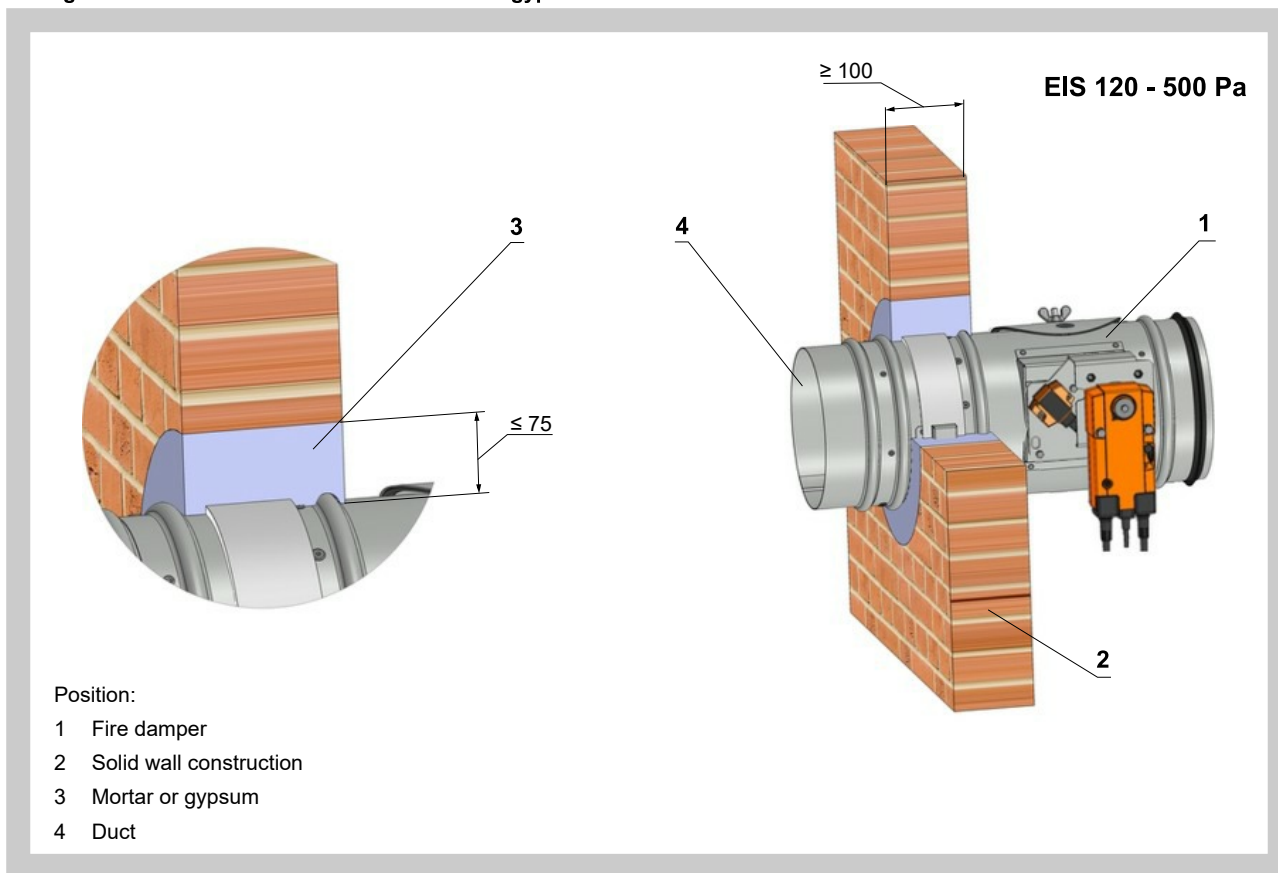

Fig. 38 Solid wall construction - stuffing box and fire protection mastic

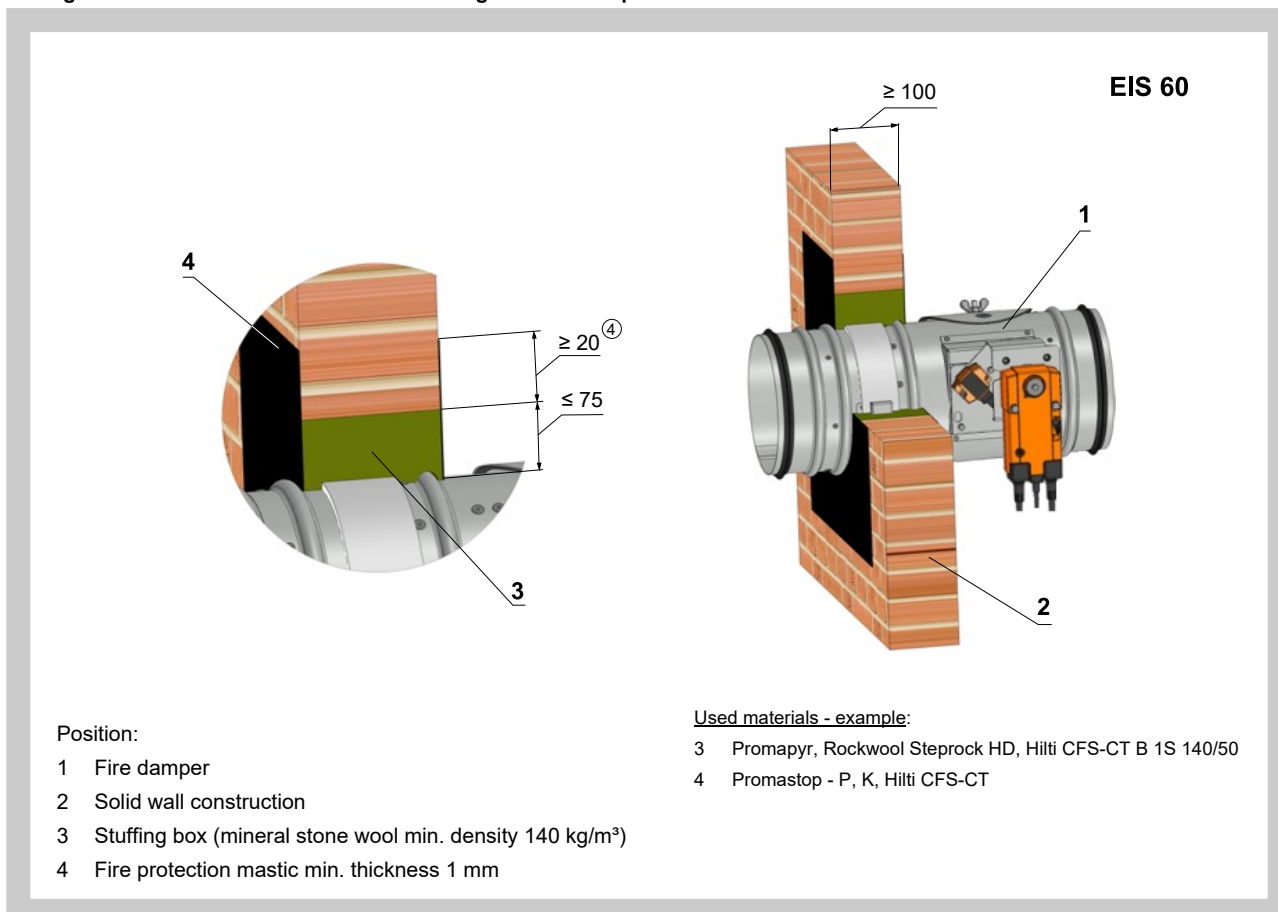
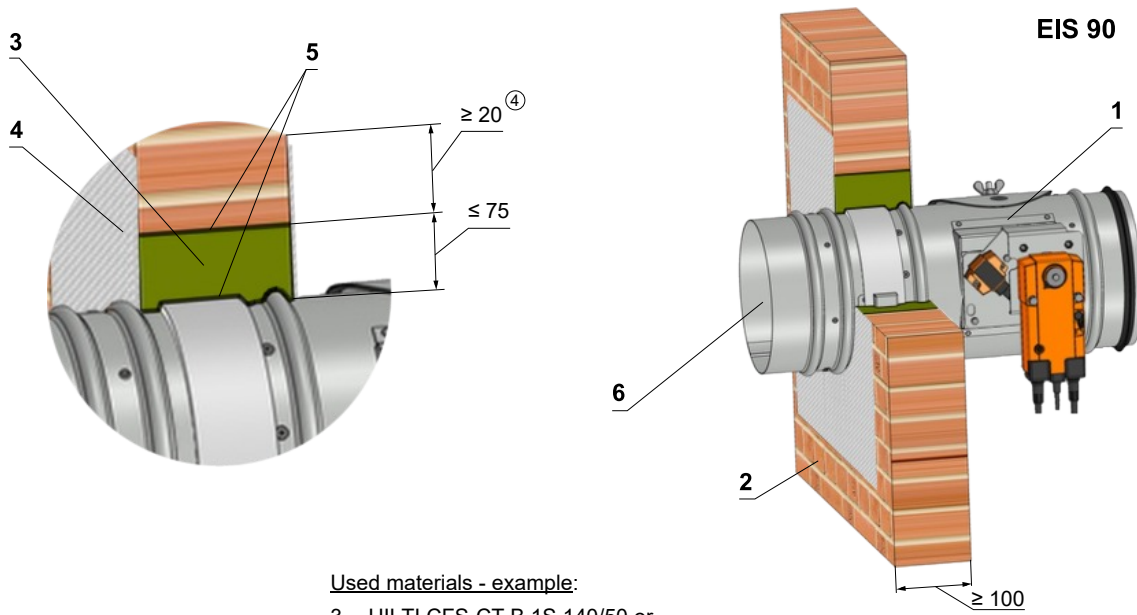

Fig. 39 Solid wall construction - stuffing box with fire protection mastic and coating



Used materials - example:

- 3 HILTI CFS-CT B 1S 140/50 or ROCKWOOL HARDROCK + coating HILTI CFS-CT

Position:

- 1 Fire damper
- 2 Solid wall construction
- 3 Stuffing box (mineral stone wool min. density 150 kg/m³)
- 4 Fire protection coating th. 1 mm
- 5 Fire protection mastic th. 1 mm
- 6 Duct

Fig. 40 Solid wall construction - fire protection foam with stucco plaster

Maximal damper dimensions 200 mm.

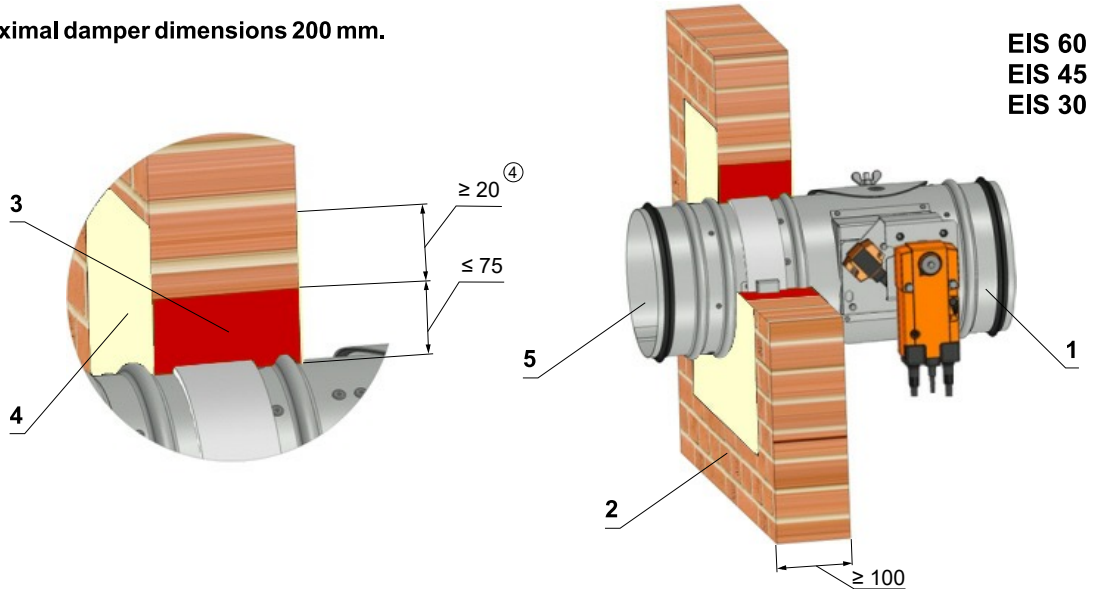

Used materials - example:

- 3 HILTI CFS-F FX - EIS 60
PROMAFOAM-C - EIS 45
Soudal, Soudafoam FR-B1 - EIS 30
DenBraven, Fire protection foam - EIS 30

Position:

- 1 Fire damper
- 2 Solid wall construction
- 3 Fire protection foam
- 4 Stucco plaster
- 5 Duct

Fig. 41 Solid wall construction - flange to flange - mortar or gypsum

EIS 90

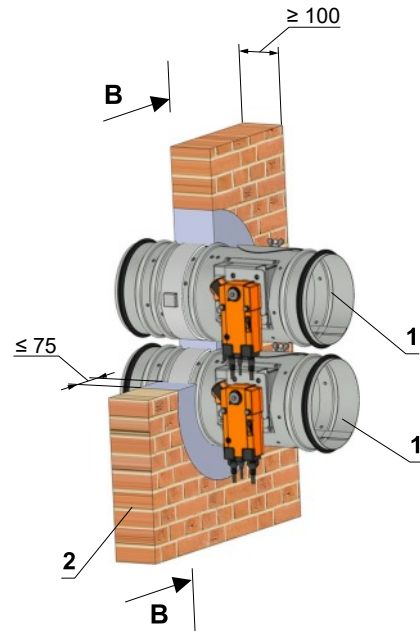
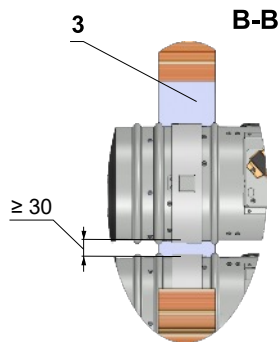
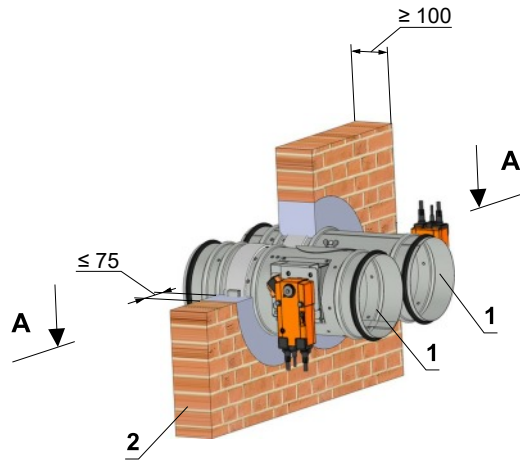
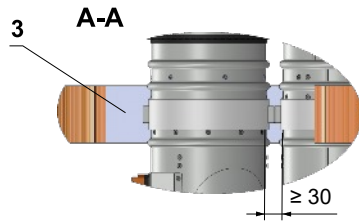

Position:

- 1 Fire damper
- 2 Solid wall construction
- 3 Mortar or gypsum

Notice:

- Installation opening for each damper has minimal dimensions D+80 mm (D+160 mm for dampers with flanges)
- Gap between damper and construction is filled by mortar or gypsum
- Distance between dampers 70 mm
- Flange to flange connection - Up to four dampers can be installed

Fig. 42 Solid wall construction - installation next to wall - mortar or gypsum and mineral wool

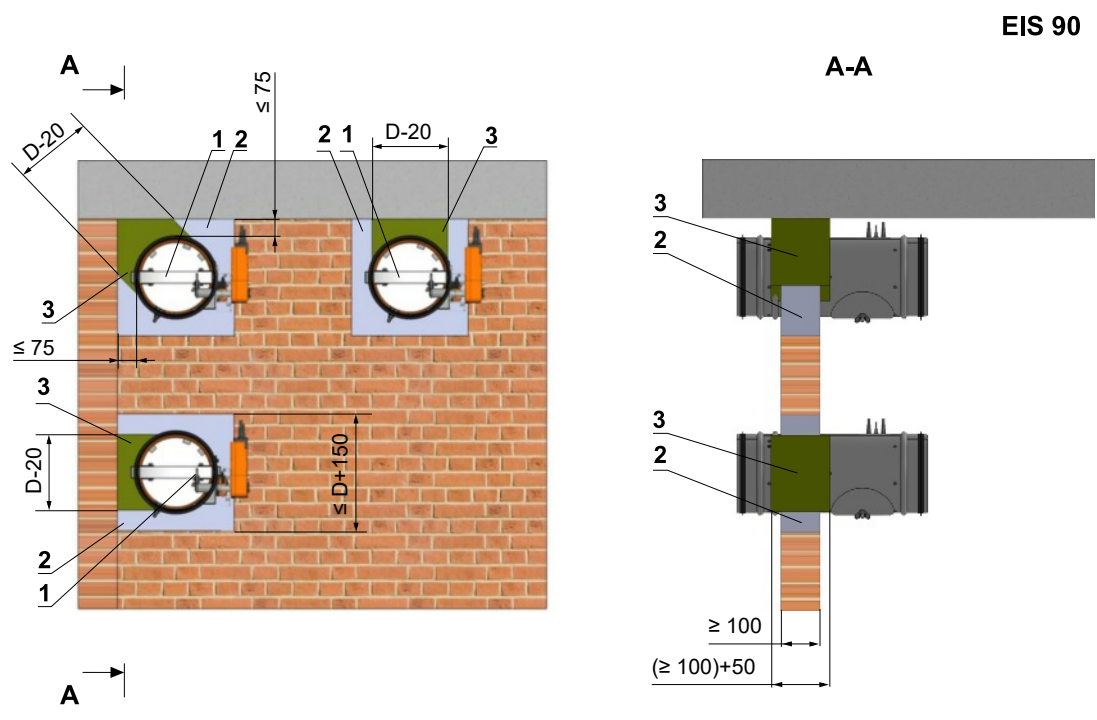

Position:

- 1 Fire damper
- 2 Mortar or gypsum
- 3 Stuffing box (mineral stone wool min. density 140 kg/m³)

Notice:

- Gap between damper and construction is filled by mortar or gypsum and mineral wool
- Wool is fixed to damper body and construction by fire protection mastic.
- Mineral wool thickness = construction thickness + 20 mm or 50 mm
- Installation is valid for ceiling construction

Fig. 43 Solid wall construction - installation next to wall, ceiling - mortar or gypsum
Solid wall construction - installation next to wall, ceiling - installation frame R1, R2 and mineral wool

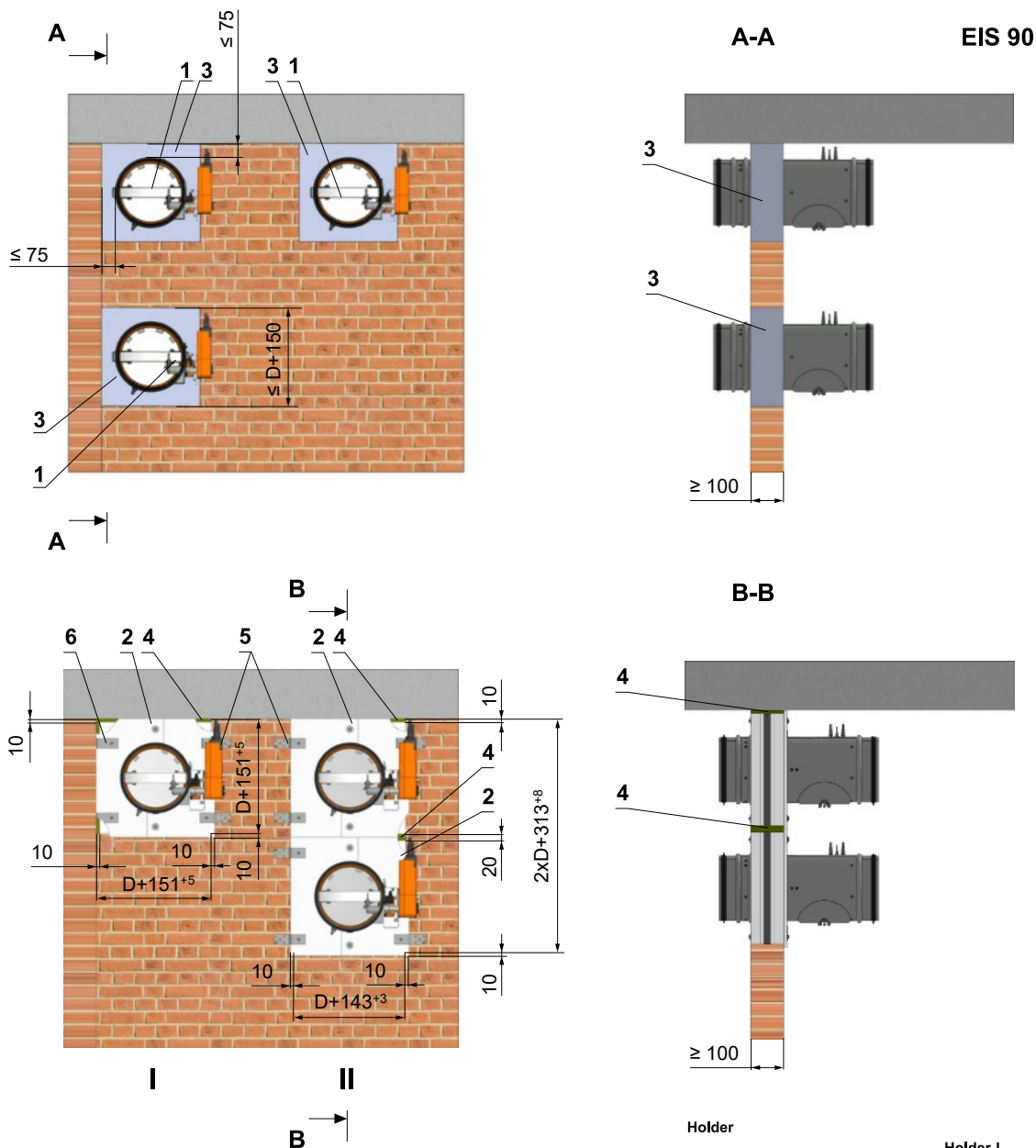

I
Holders No. X = X1/2
Holders No.-L Z = X1/2
Screws No. Y

II
Holders No. X = X1 - Z1
Holders No.-L Z = Z1/2
Screws No. Y

Dimensions	Number X1	Number Y	Number Z1
$D \leq 400$	4	8	2
$400 < D \leq 800$	8	16	4
$800 < D \leq 1000$	12	24	6

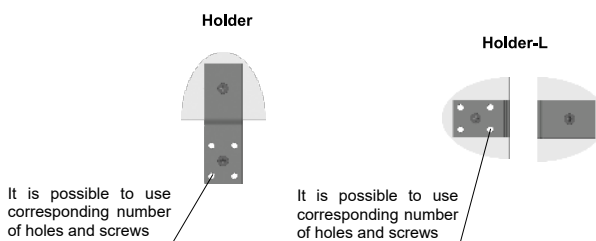

Position:

- 1 Fire damper
- 2 Fire damper with installation frame R1, R2
- 3 Mortar or gypsum
- 4 Stuffing box (mineral stone wool min. density 140 kg/m³)
- 5 Holder
- 6 Holder L

Notice:

- Gap between frame and damper body and frame and construction must be filled by glue (PROMAT K84).
- Wool is fixed to installation frame and construction by fire protection mastic.
- Installation is valid for ceiling construction

Fig. 44 Solid wall construction - installation next to wall, ceiling - installation frame R3, R4, R5 and mineral wool

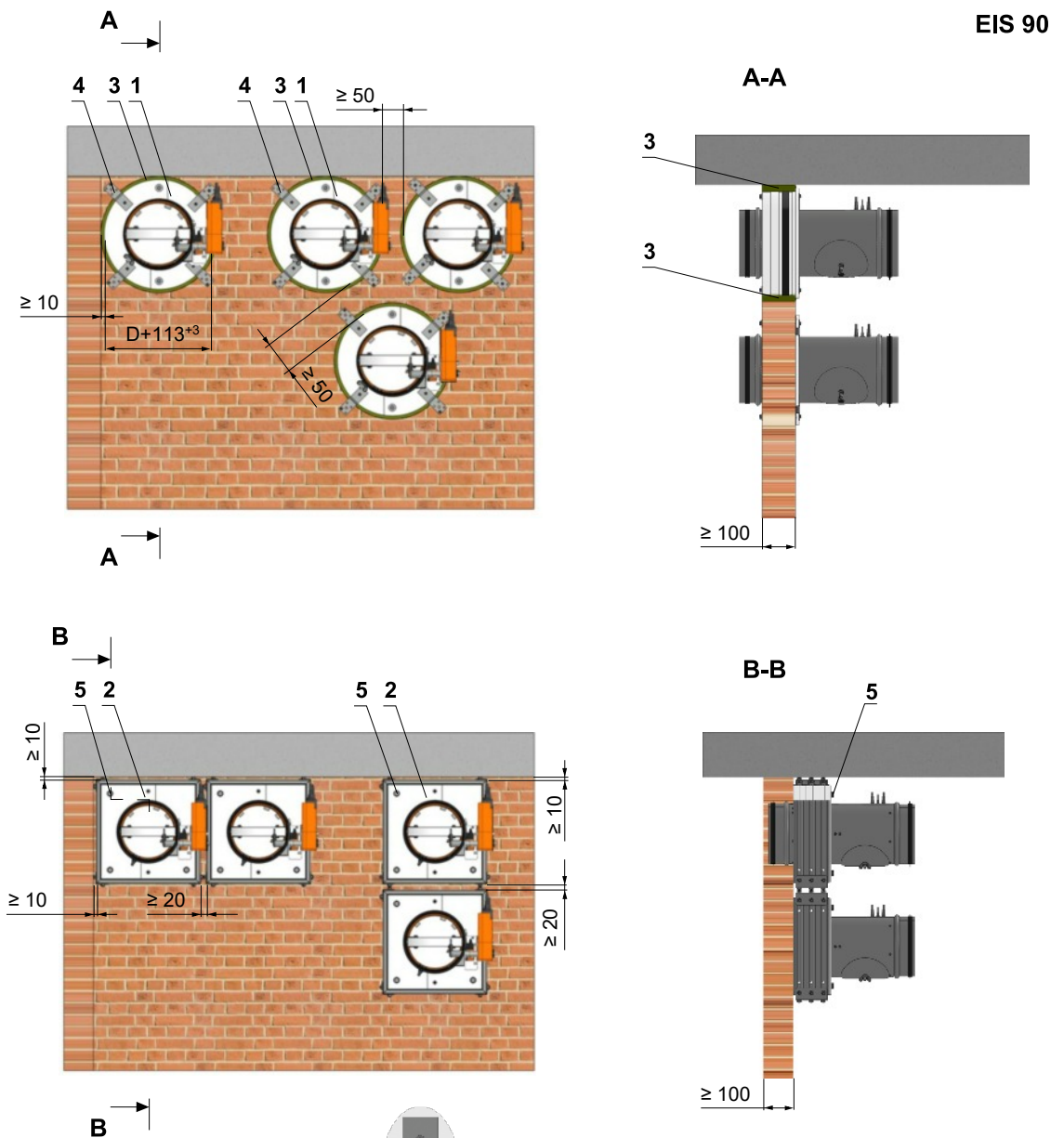

Holders No. X
Screws No. Y

Dimensions	Number X	Number Y
D ≤ 400	4	8
400 < D ≤ 800	8	16
800 < D ≤ 1000	12	24

Position:

- 1 Fire damper with installation frame R3, R4
- 2 Fire damper with installation frame R5
- 3 Stuffing box (mineral stone wool min. density 140 kg/m³)
- 4 Holder
- 5 Fitting with threaded rods or steel bracket

Fitting with steel bracket



Fitting with threaded rods

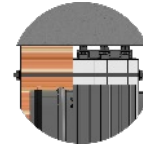

Notice:

- Wool is fixed to installation frame and construction by fire protection mastic.
- Installation is valid for ceiling construction

Fig. 45 Solid wall construction - stuffing box, fire protection mastic and cement lime plate

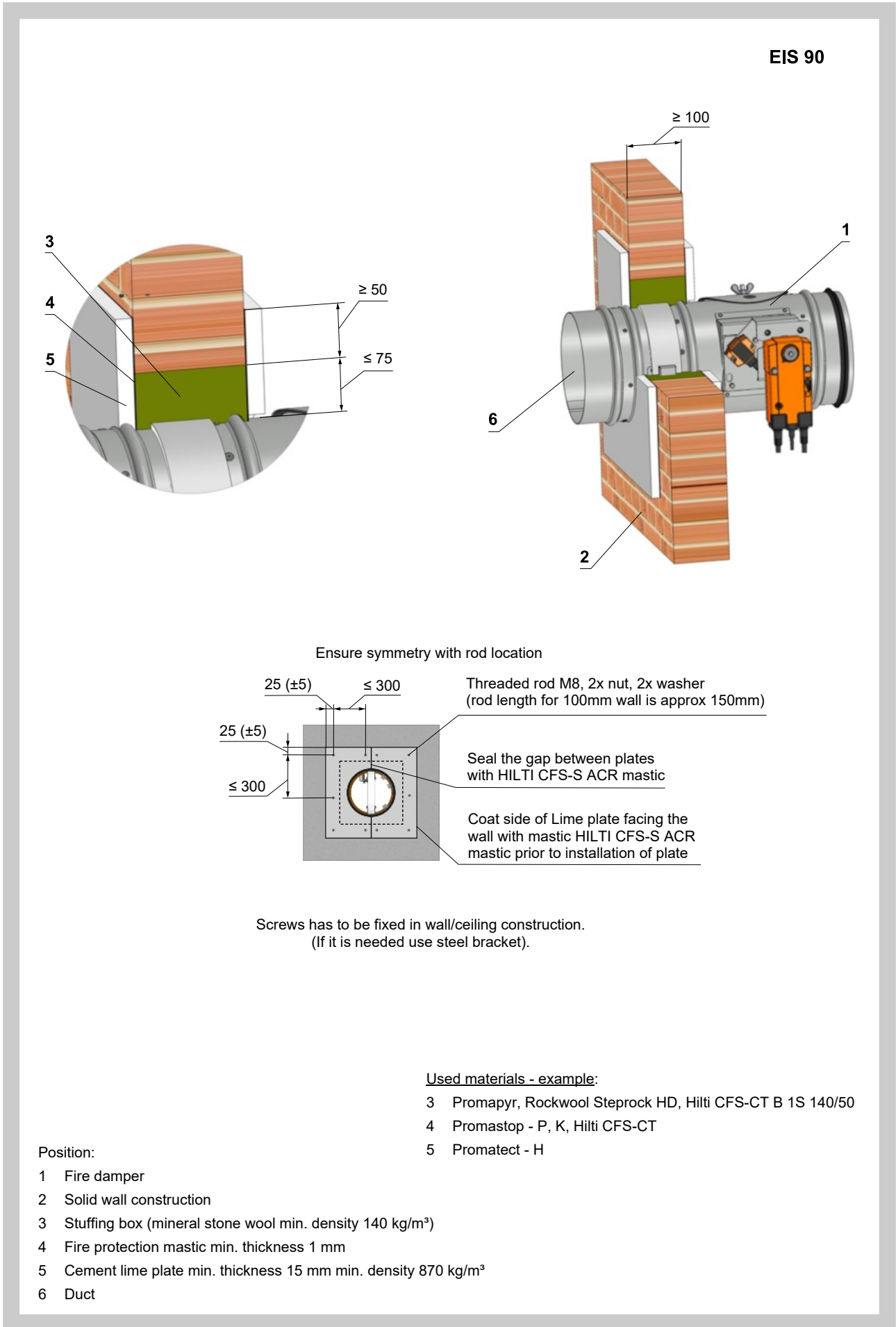
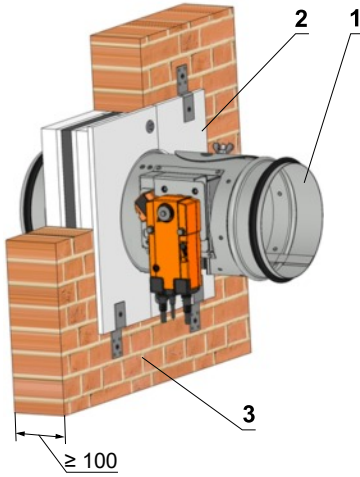

Fig. 46 Solid wall construction - installation frame R1, R2, R3, R4, R5

EIS 90

Installation frame R1, R2



Installation frame R3, R4

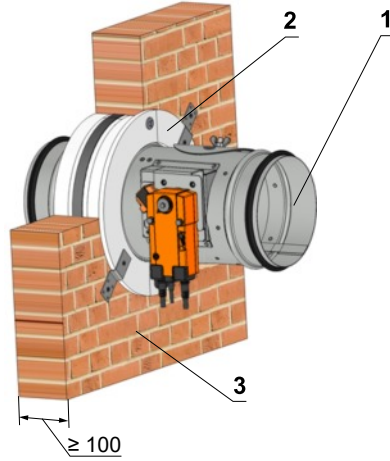

Installation frame R5 (DN 100 - 200)

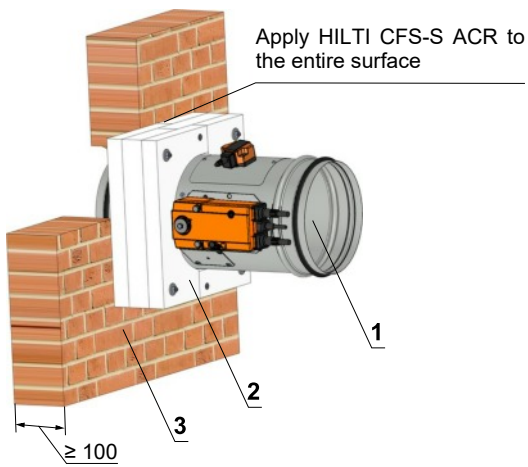

Installation frame R5 (DN 225 - 800)

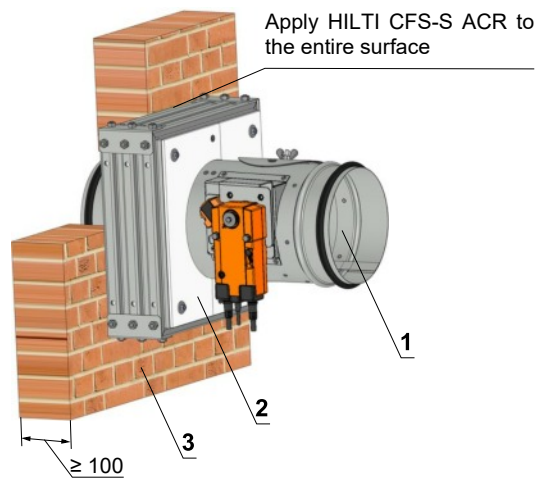

Position:

- 1 Fire damper
- 2 Installation frame
- 3 Solid wall construction

Installation details see chapter 8

Fig. 47 Solid wall construction - Weichschott / Ablative Coated Batt

EIS 90

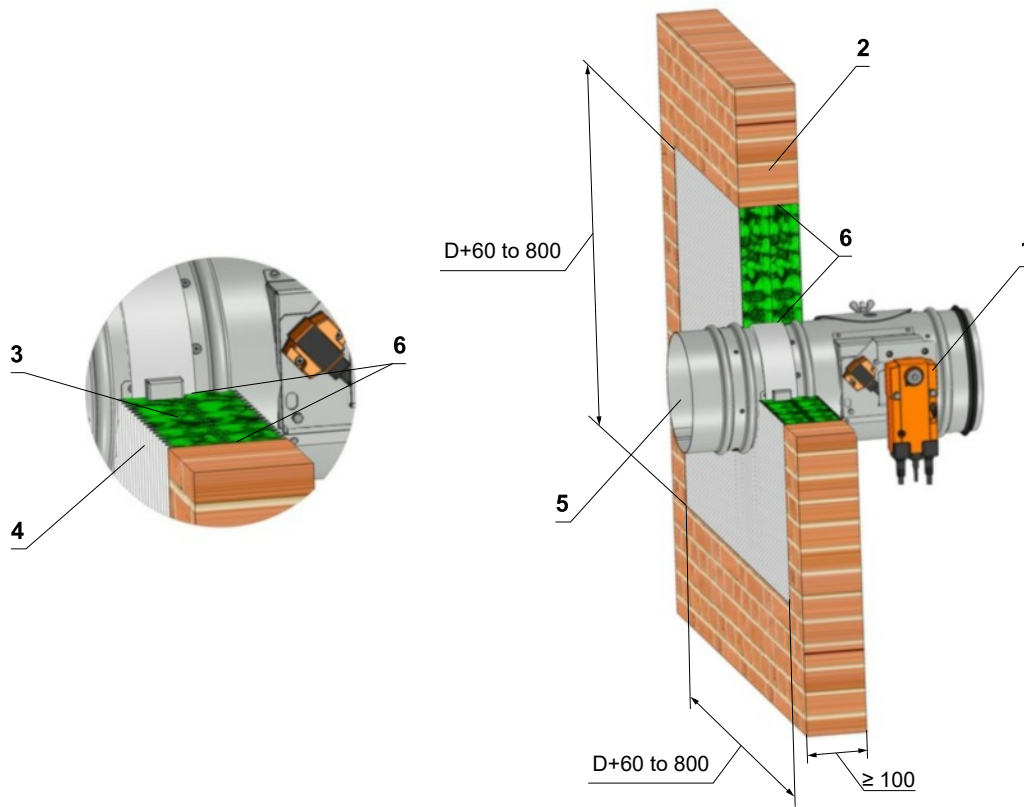

Position:

- 1 Fire damper
- 2 Solid wall construction
- 3 Fire resistant board
- 4 Fire stop coating thickness 1 mm
- 5 Duct
- 6 Fire resistant mastic - fill the gap on both sides of the fire separation construction and around the perimeter of penetration and damper body.

Used materials - example:

- 3 Hilti CFS-CT B 1S 140/50
- 4 Hilti CFS-CT
- 6 Hilti CFS-S ACR

Fig. 48 Solid wall construction - flange to flange - installation frame R1

EIS 90

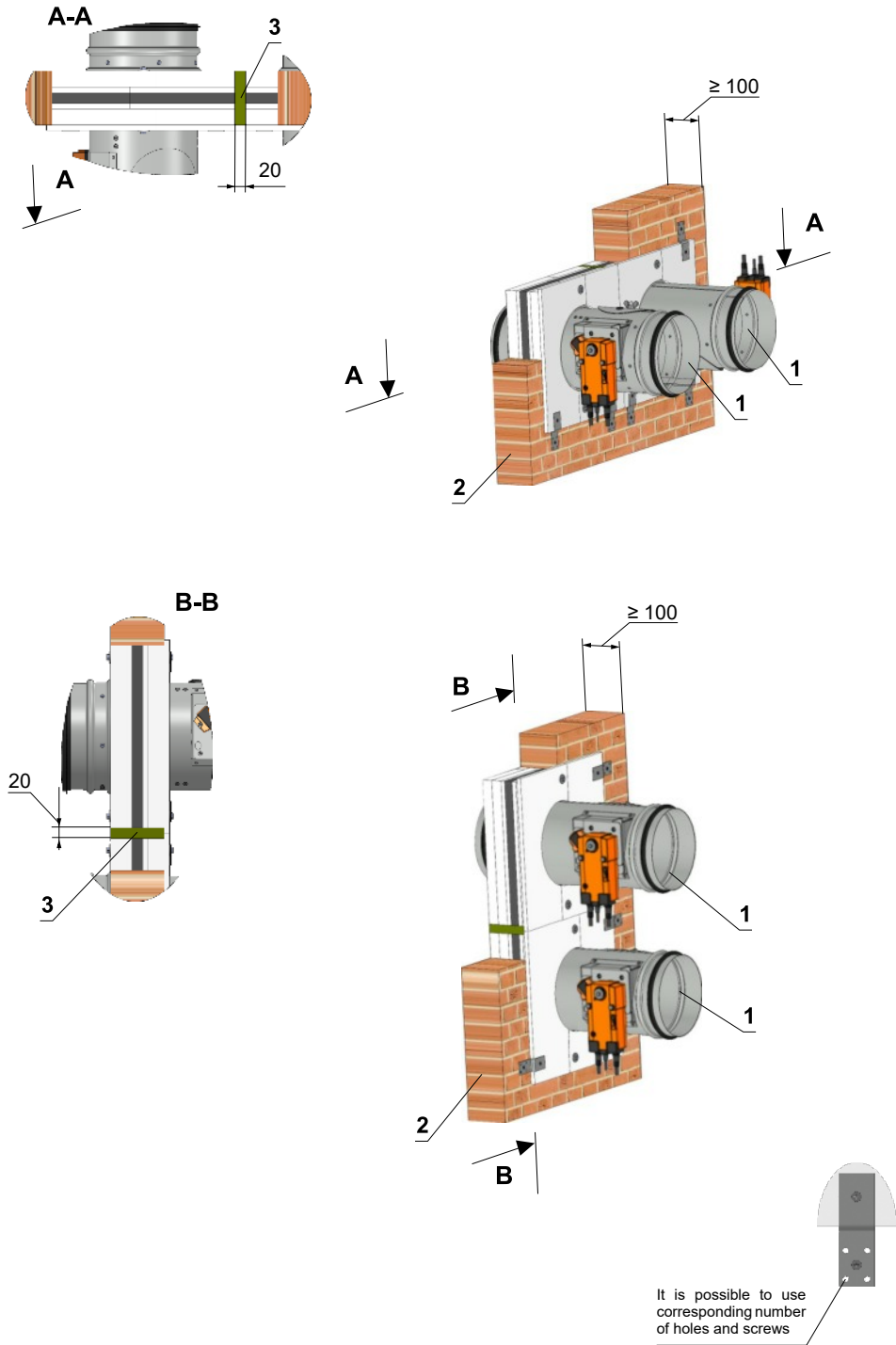

Position:

- 1 Fire damper with installation frame R1
- 2 Solid wall construction
- 3 Mineral stone wool min. density 140 kg/m³

Notice:

- Gap between frame and damper body and frame and construction must be filled by glue (PROMAT K84).
- Distance between dampers 160 mm
- Flange to flange connection - Up to four dampers can be installed

Holders No. X = (2xZB1) + (2xZH1)
Screws No. Y = 2xX

Dimensions	Number ZB1	Number ZH1
D1 ≤ 400	1	1
400 < D1 ≤ 800	2	2
800 < D1 ≤ 1260	3	3
D1 ≤ 1600	4	4

D1 = D or D1 = 2xD

6.3. Installation outside solid wall construction

Fig. 49 Outside solid wall construction - mineral wool - mortar or gypsum

Minimum and maximum distance between the wall and fire damper when installation remote from the wall is unlimited.

EIS 90
EIS 60

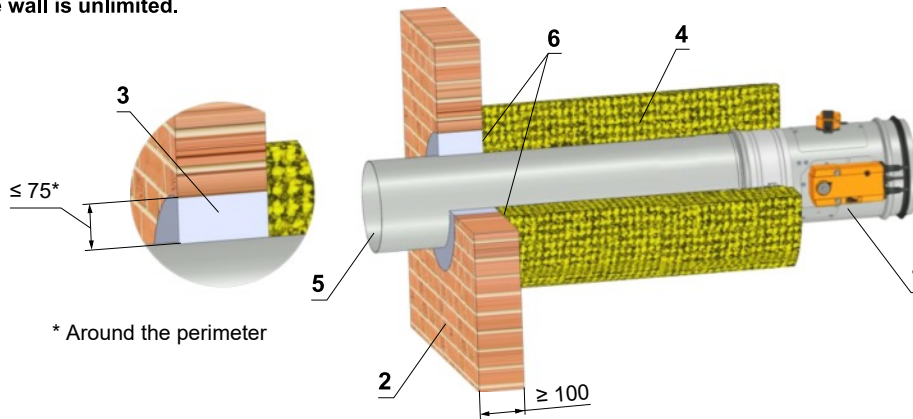

* Around the perimeter

Position:

- 1 Fire damper
- 2 Solid wall construction
- 3 Mortar or gypsum
- 4 Stone wool with wired mat on one side, density 66 kg/m³
- 5 Duct
- 6 Apply ISOVER Protect BSK glue on the insulation and stick it to the fire separation construction ***

Used materials - example:**

- 4 DN 100 ÷ DN 800 - System ISOVER_ULTIMATE PROTECT, th. 100 mm - EIS 60
- DN 100 ÷ DN 315 - System ISOVER_ULTIMATE PROTECT, th. 120 mm (2x60 mm) - EIS 90
- DN 350 ÷ DN 800 - System ISOVER_ULTIMATE PROTECT, th. 160 mm (100+60 mm) - EIS 90

** Insulation materials can be replaced by another approved fire sealing system with equivalent properties.

The maximum distance of the fire damper from the structure is not limited.

*** When installing the insulation, follow the ISOVER manufacturer's instructions.

The duct at the point of penetration does not have to be anchored to the fire wall construction, see chapter 9.

Fig. 50 Outside solid wall construction - mineral wool - stuffing box and fire protection mastic

Minimum and maximum distance between the wall and fire damper when installation remote from the wall is unlimited.

EIS 90
EIS 60

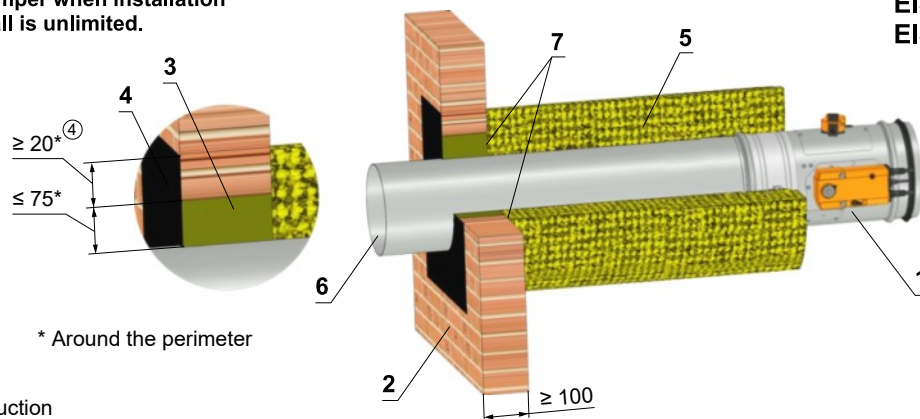

* Around the perimeter

Position:

- 1 Fire damper
- 2 Solid wall construction
- 3 Stuffing box (mineral stone wool min. density 140 kg/m³)
- 4 Fire protection mastic min. thickness 1 mm
- 5 Stone wool with wired mat on one side, density 66 kg/m³
- 6 Duct
- 7 Apply ISOVER Protect BSK glue on the insulation and stick it to the fire separation construction ***

Used materials - example:**

- 3 Promapyr, Rockwool Steprock HD, Hilti CFS-CT B 1S 140/50
- 4 Promastop - P, K, Hilti CFS-CT
- 5 DN 100 ÷ DN 800 - System ISOVER_ULTIMATE PROTECT, th. 100 mm - EIS 60
- DN 100 ÷ DN 315 - System ISOVER_ULTIMATE PROTECT, th. 120 mm (2x60 mm) - EIS 90
- DN 350 ÷ DN 800 - System ISOVER_ULTIMATE PROTECT, th. 160 mm (100+60 mm) - EIS 90

** Insulation materials can be replaced by another approved fire sealing system with equivalent properties.

The maximum distance of the fire damper from the structure is not limited.

*** When installing the insulation, follow the ISOVER manufacturer's instructions.

The duct at the point of penetration must be anchored to the fire wall construction, see chapter 9.

Fig. 51 Installation outside of solid wall construction - mineral wool, stuffing box, fire protection mastic and cement lime plate

Minimum and maximum distance between the wall and fire damper when installation remote from the wall is unlimited.

EIS 90

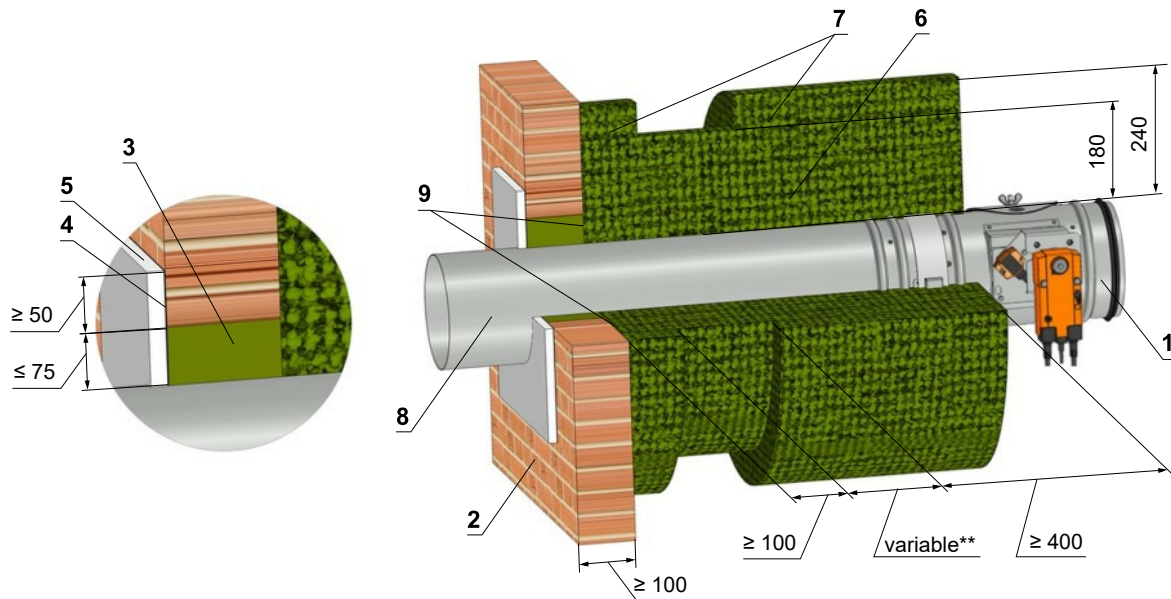

Ensure symmetry with rod location

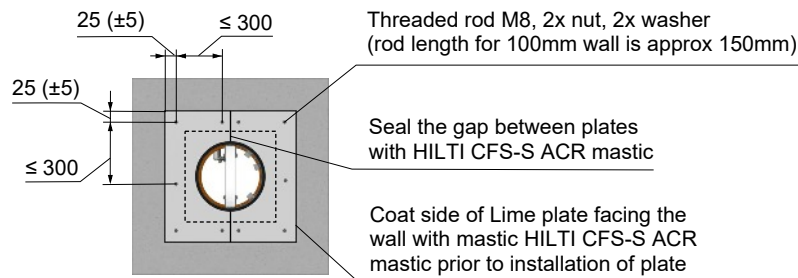

Screws has to be fixed in wall/ceiling construction.
(If it is needed use steel bracket).

Position:

- 1 Fire damper
- 2 Solid wall construction
- 3 Stuffing box (mineral stone wool min. density 140 kg/m³)
- 4 Fire protection mastic min. thickness 1 mm
- 5 Cement lime plate min. thickness 15 mm (min. density 870 kg/m³)
- 6 Stone wool with one side stitched wire fencing (min. density 105 kg/m³), thickness 180 mm (e.g. 3x60 mm)
- 7 Stone wool with one side stitched wire fencing (min. density 105 kg/m³), thickness 60 mm
- 8 Duct
- 9 Apply Rockwool Firepro glue on the insulation and stick it to the fire separation construction ***

Used materials - example:*

- 3 Promapyr, Rockwool Steprock HD, Hilti CFS-CT B 1S 140/50
- 4 Promastop - P, K, Hilti CFS-CT
- 5 Promatect - H
- 6 Rockwool Wired Mat 105 th. 3x60 mm
- 7 Rockwool Wired Mat 105 th. 60 mm

* Stuffing box, fire protection mastic, cement lime plate and insulation materials can be replaced by another approved fire sealing system for damper installation with equivalent material properties.

** Depends on the distance of the flap from the construction, when the maximum distance from the construct is not limited and according to EN 15882-2 must use the required number of hinges according to EN 13366-1:2014.

*** When installing the insulation, follow the Rockwool manufacturer's instructions.

The duct at the point of penetration must be anchored to the fire wall construction, see chapter 9.

Fig. 52 Installation outside of solid wall construction - installation frame R6 with cement lime plates

Installation frame R6

EIS 90

Minimum and maximum distance between the wall and fire damper when installation remote from the wall is unlimited.

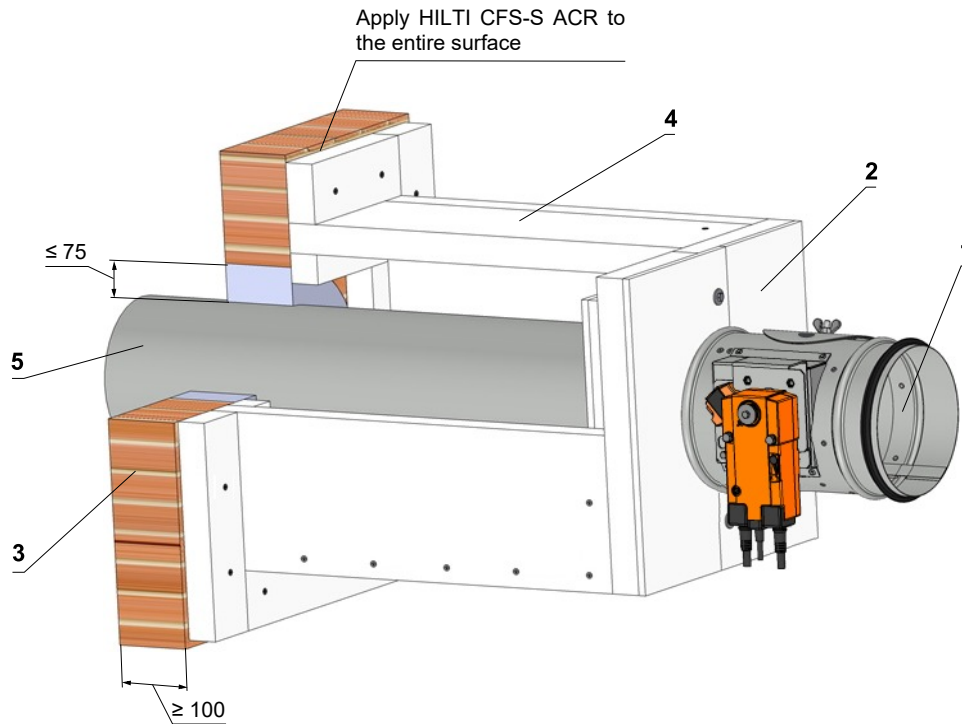

Position:

- 1 Fire damper
- 2 Installation frame R6
- 3 Solid wall construction
- 4 Cement lime plate - all parts are glued with glue Promat K84 and secured by screws.
- 5 Duct

Installation details see chapter 8.

6.4. Installation in gypsum wall construction

Fig. 53 Gypsum wall construction - mortar or gypsum

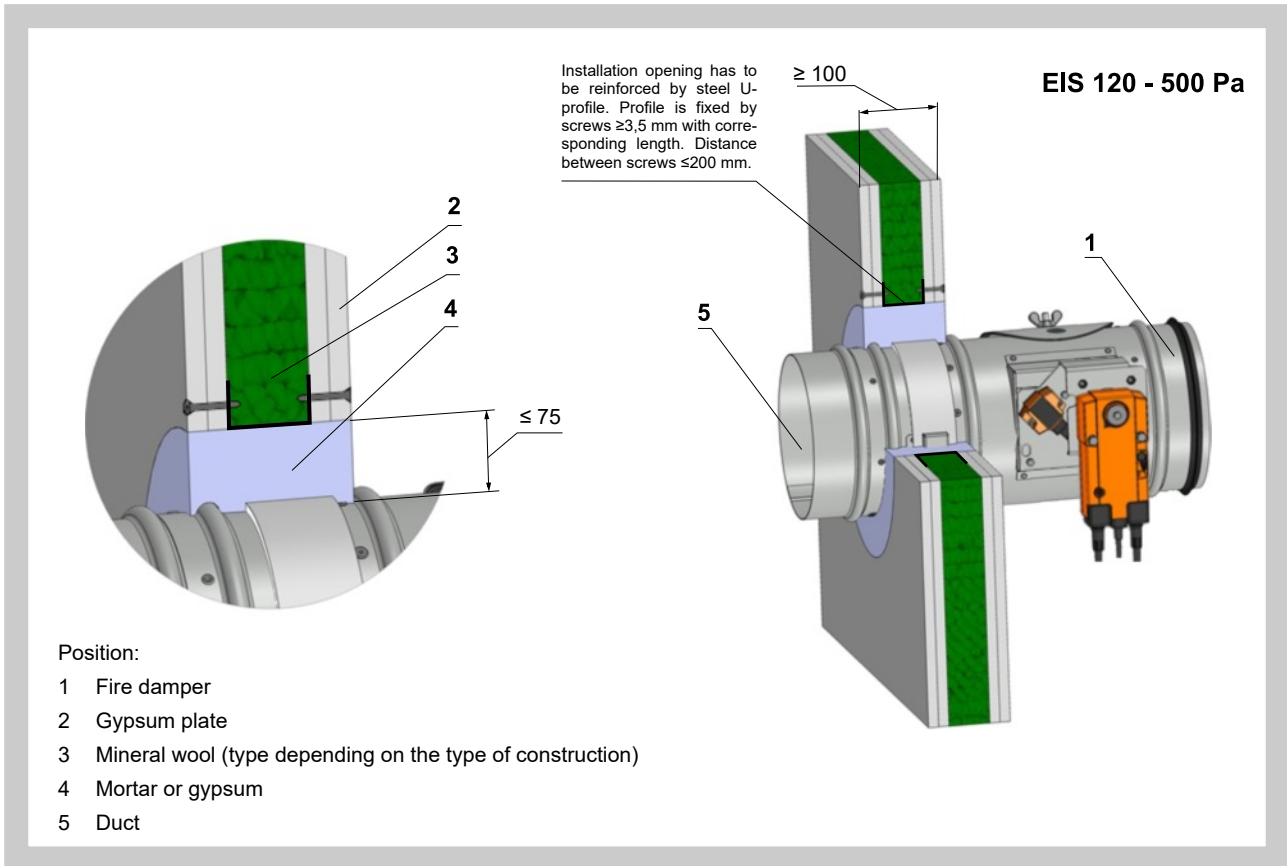

Fig. 54 Gypsum wall construction - stuffing box and fire protection mastic

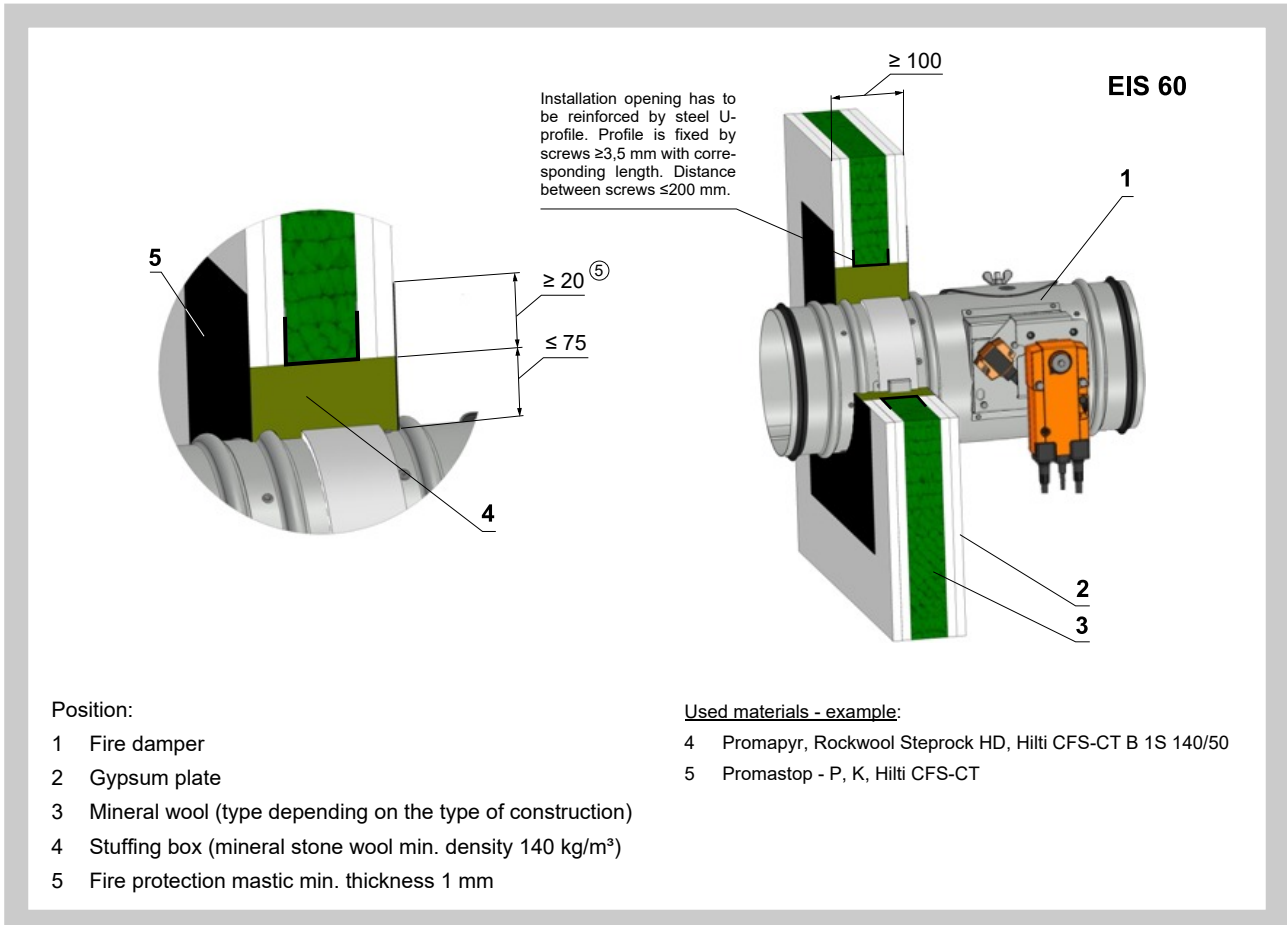

Fig. 55 Gypsum wall construction - stuffing box with fire protection mastic and coating

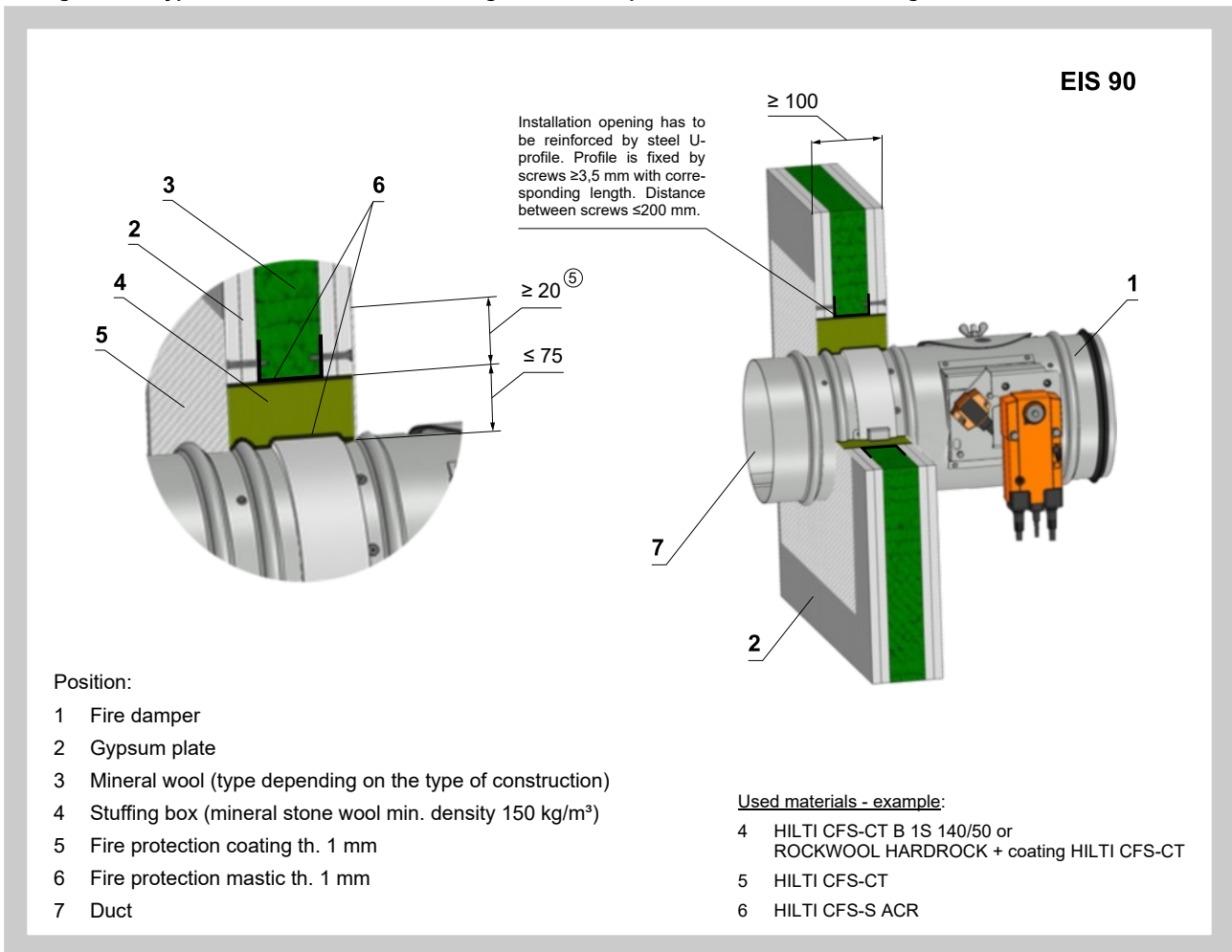

Fig. 56 Gypsum wall construction - fire protection foam with stucco plaster

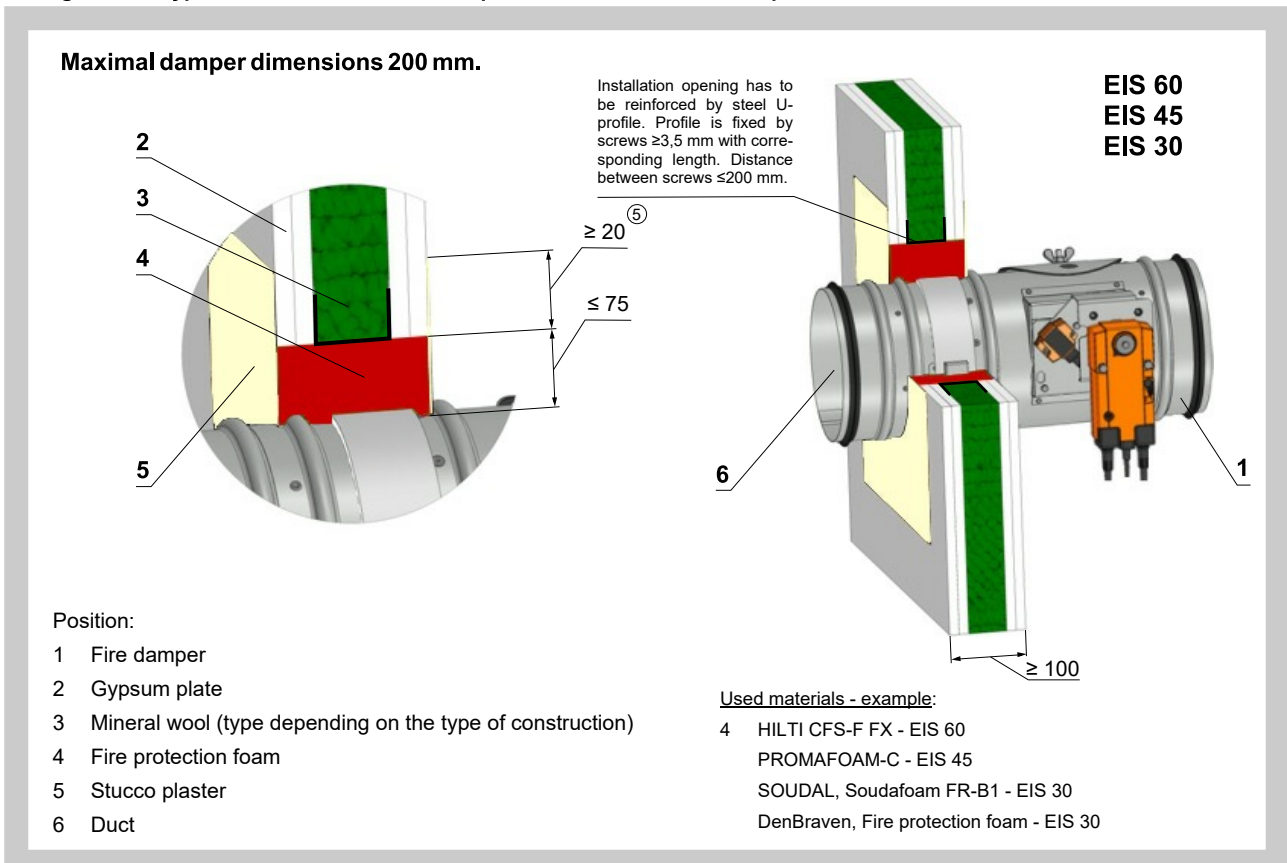
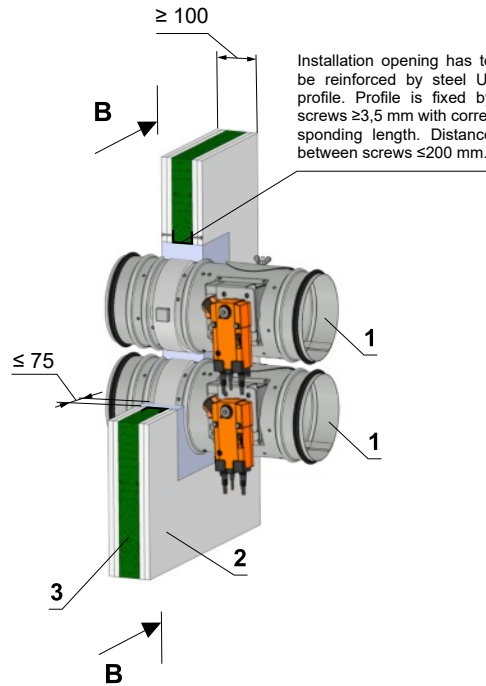
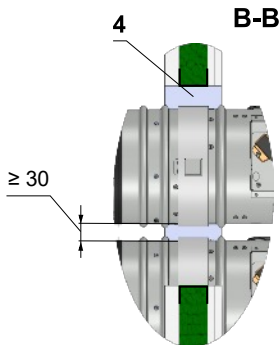
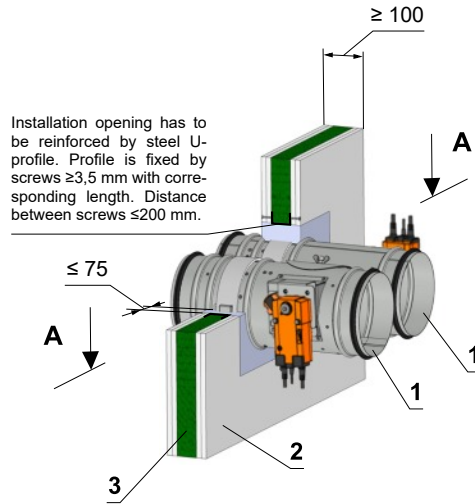
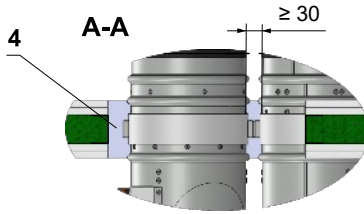

Fig. 57 Gypsum wall construction - flange to flange - mortar or gypsum

EIS 90



Position:

- 1 Fire damper
- 2 Gypsum plate
- 3 Mineral wool (type depending on the type of construction)
- 4 Mortar or gypsum

Notice:

- The installation opening for each fire damper has a minimum size of $a \times b = (D + 97^{+3} \text{ mm}) + 20 \text{ mm} \times (D + 97^{+3} \text{ mm})$ or $a \times b = (D + 97^{+3} \text{ mm}) \times (D + 97^{+3} \text{ mm}) + 20 \text{ mm}$
- Gap between damper and construction is filled by mortar or gypsum
- Distance between dampers 70 mm
- Flange to flange connection - Up to four dampers can be installed

Fig. 58 Gypsum wall construction - installation next to wall, ceiling - mortar or gypsum and mineral wool

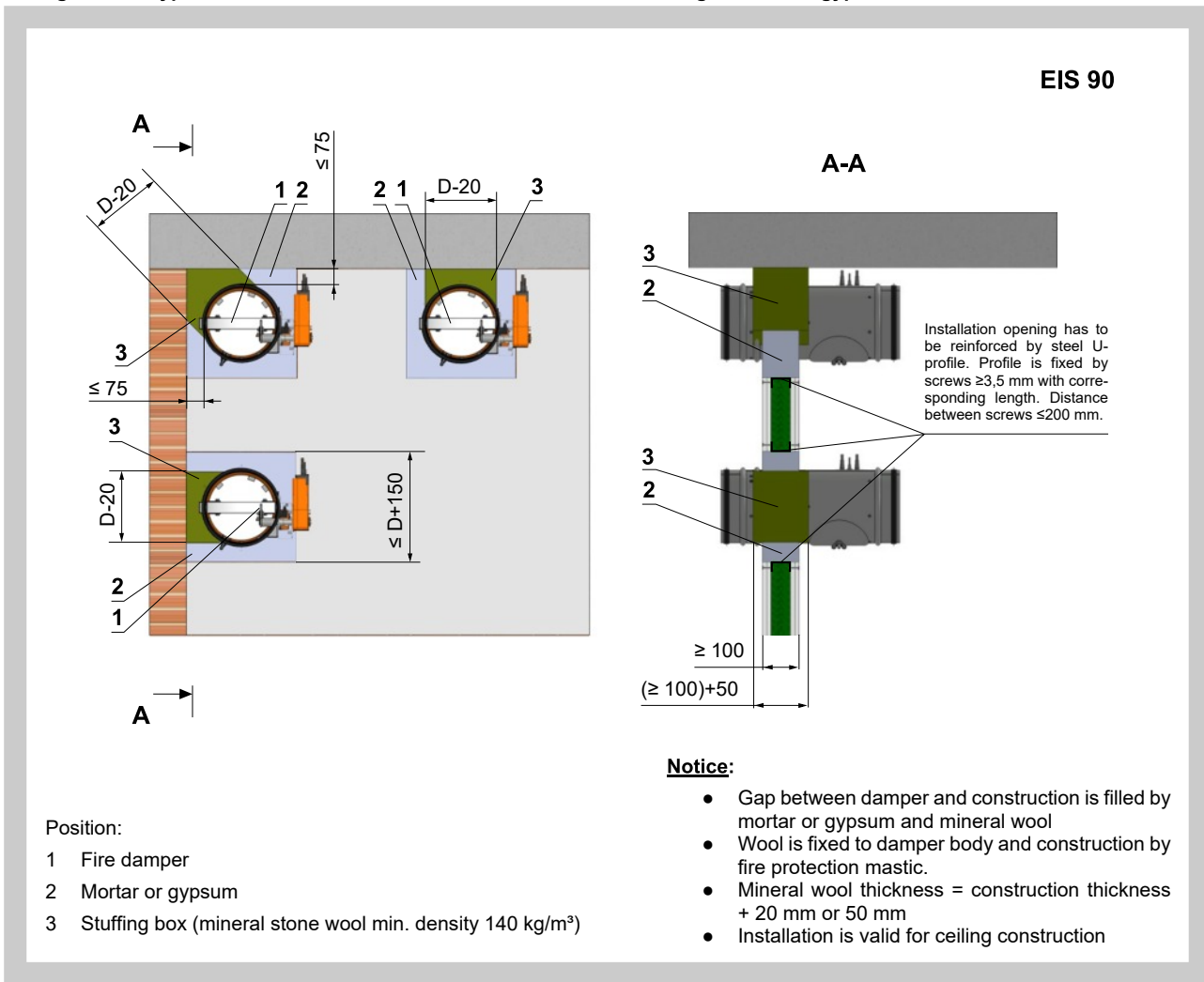
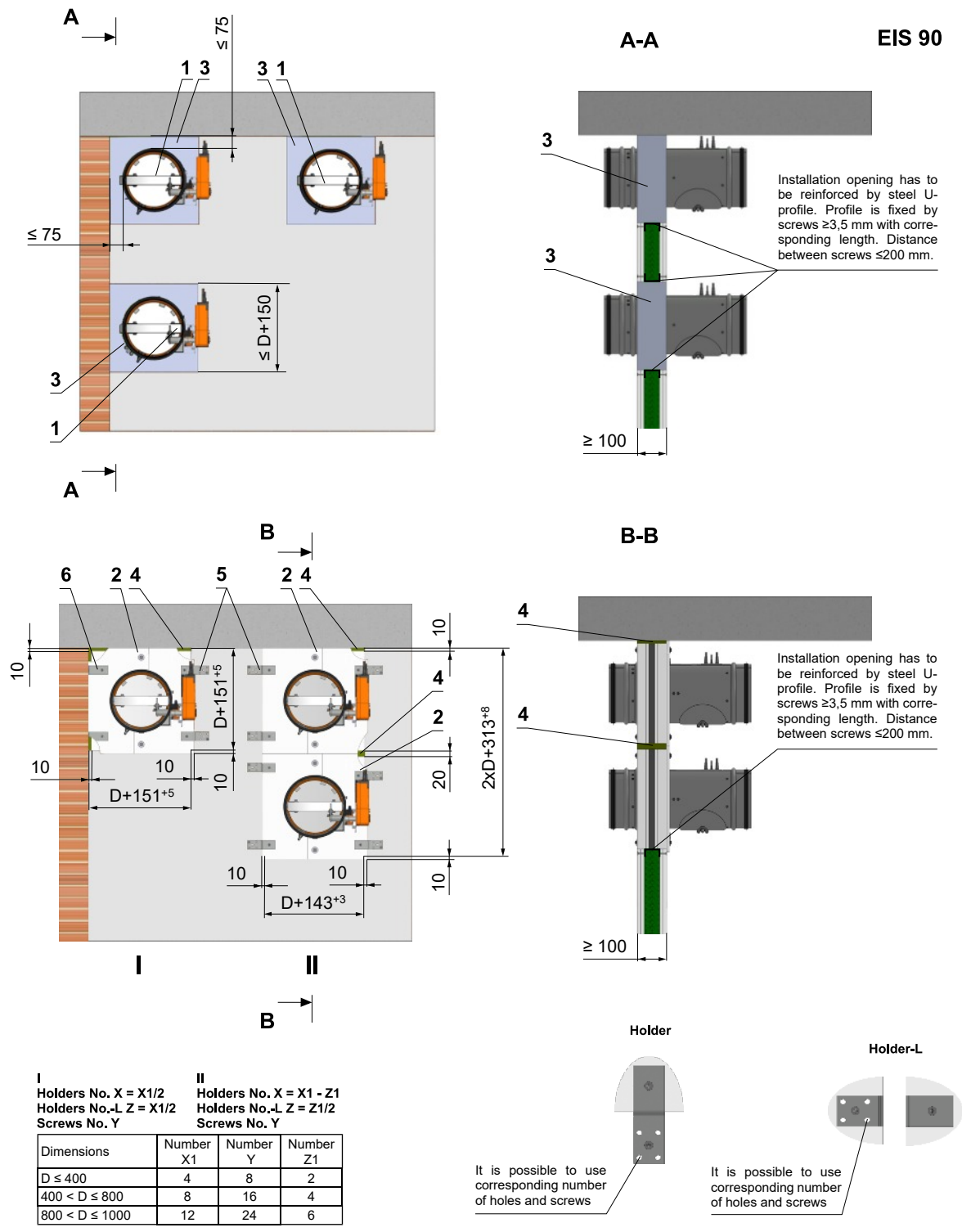

Fig. 59 Gypsum wall construction - installation next to wall, ceiling - mortar or gypsum
Gypsum wall construction - Installation next to wall, ceiling - installation frame R1, R2 and mineral wool



Position:

- 1 Fire damper
- 2 Fire damper with installation frame R1, R2
- 3 Mortar or gypsum
- 4 Stuffing box (mineral stone wool min. density 140 kg/m³)
- 5 Holder
- 6 Holder L

Notice:

- Gap between frame and damper body and frame and construction must be filled by glue (PROMAT K84).
- Wool is fixed to installation frame and construction by fire protection mastic.
- Installation is valid for ceiling construction

Fig. 60 Gypsum wall construction - installation next to wall, ceiling - installation frame R5

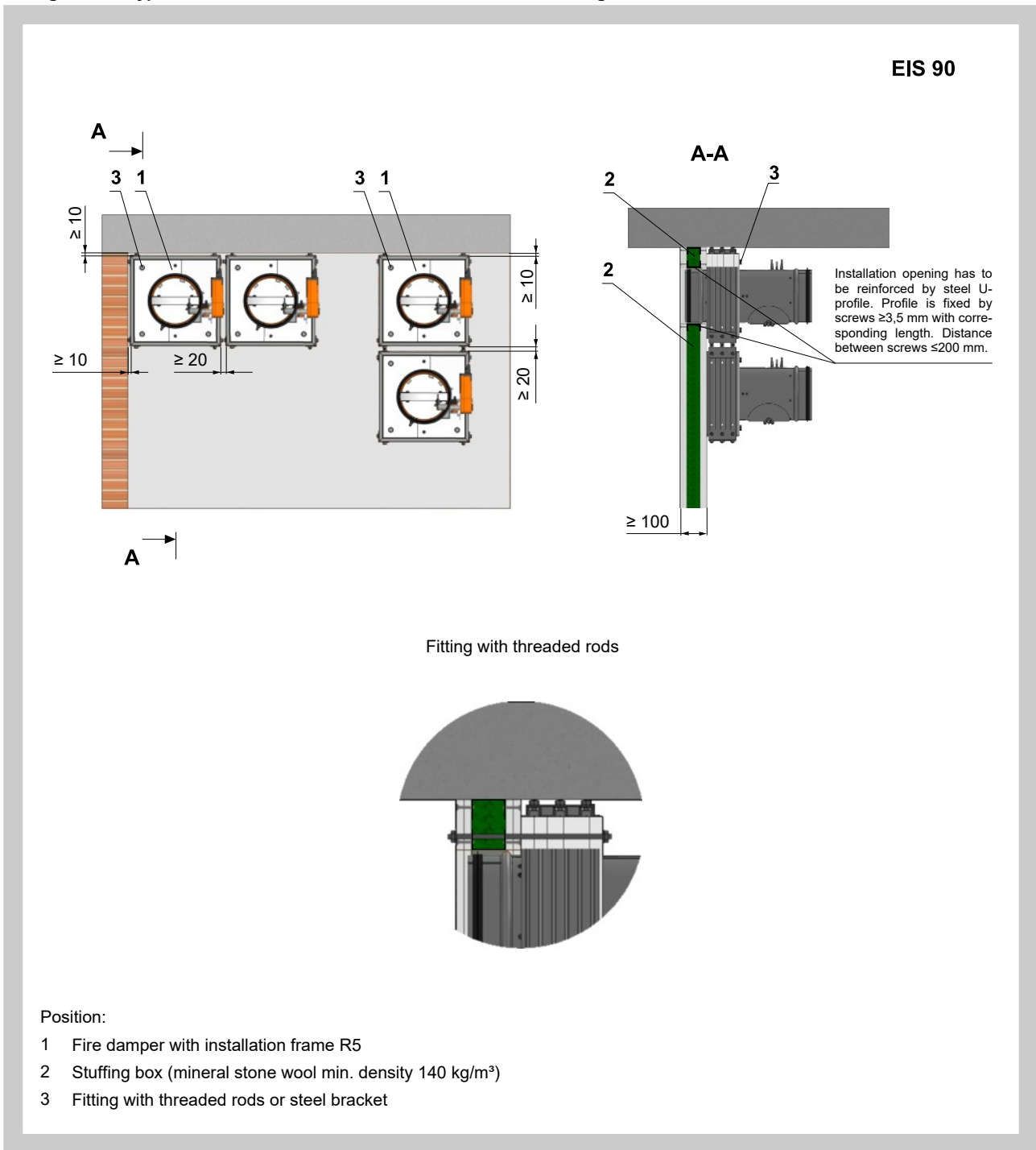
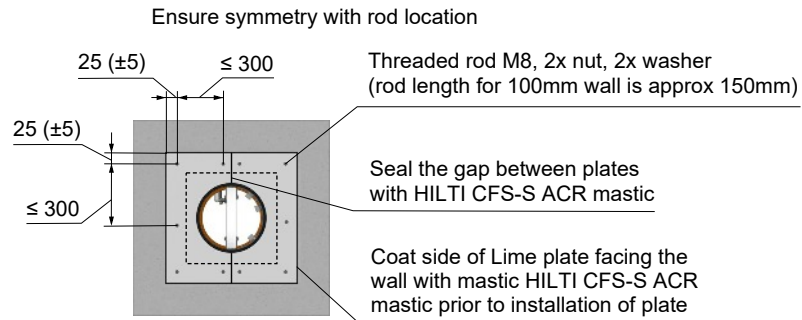
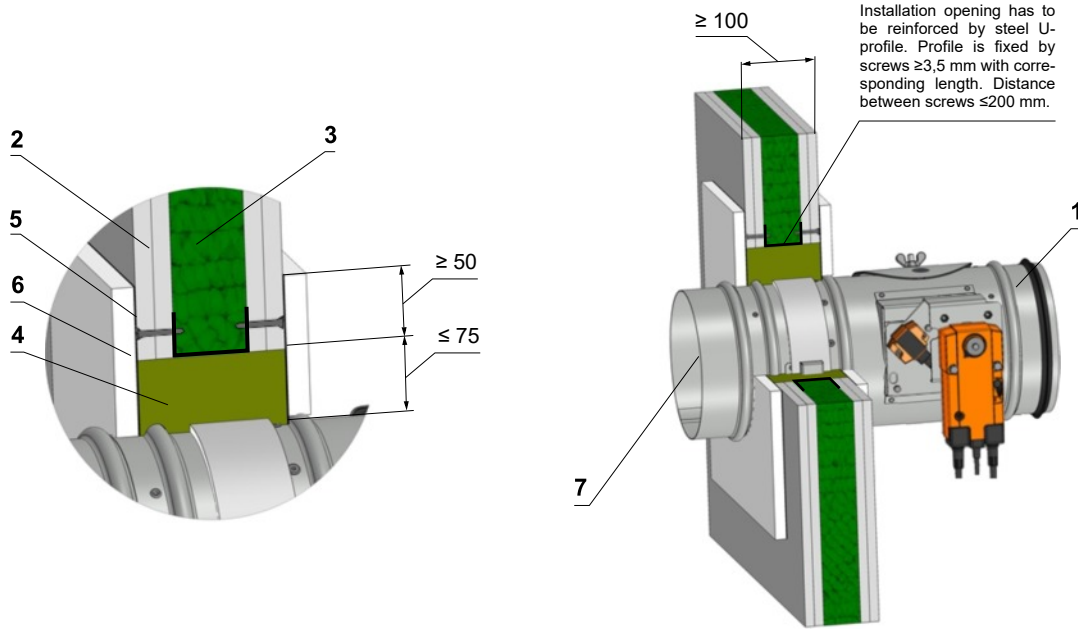

Fig. 61 Gypsum wall construction - stuffing box, fire protection mastic and cement lime plate

EIS 90



Screws has to be fixed in wall/ceiling construction.
(If it is needed use steel bracket).

Used materials - example:

- 4 Promapyr, Rockwool Steprock HD, Hilti CFS-CT B 1S 140/50
- 5 Promastop - P, K, Hilti CFS-CT
- 6 Promatect - H

Position:

- 1 Fire damper
- 2 Gypsum plate
- 3 Mineral wool (type depending on the type of construction)
- 4 Stuffing box (mineral stone wool min. density 140 kg/m³)
- 5 Fire protection mastic min. thickness 1 mm
- 6 Cement lime plate min. th. 15 mm (min. density 870 kg/m³)
- 7 Duct

Fig. 62 Gypsum wall construction - installation frame R1, R2, R3, R4, R5

EIS 90

Installation frame R1, R2

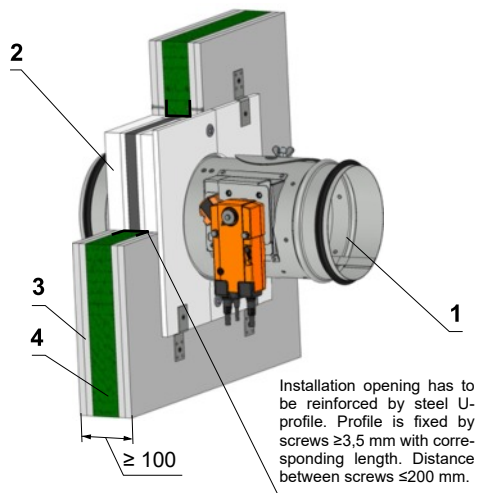

Installation frame R3, R4

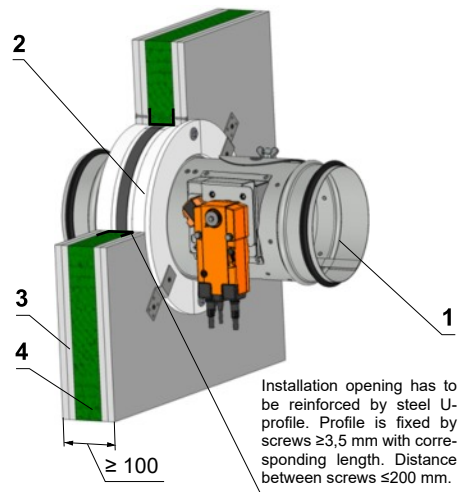

Installation frame R5 (DN 100 - 200)

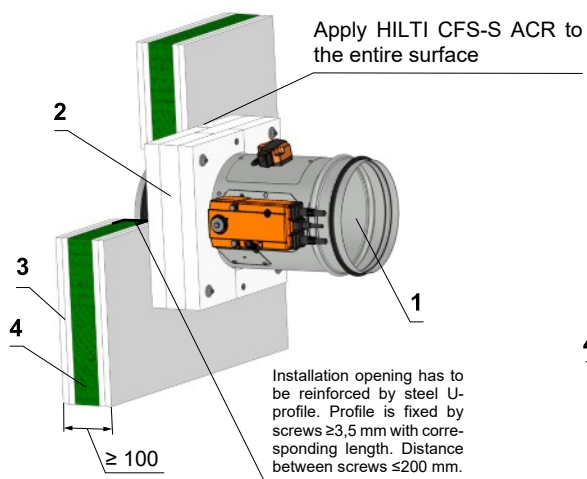

Installation frame R5 (DN 225 - 800)

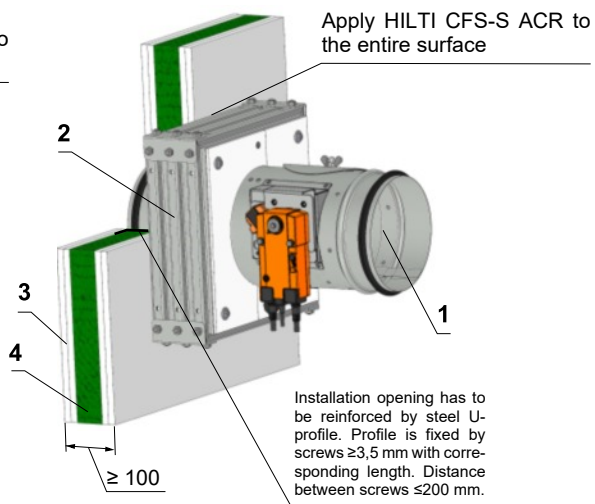

Position:

- 1 Fire damper
- 2 Installation frame
- 3 Gypsum plate
- 4 Mineral wool (type depending on the type of construction)

Installation details see chapter 8

Fig. 63 Gypsum wall construction - Weichschott / Ablative Coated Batt

EIS 90

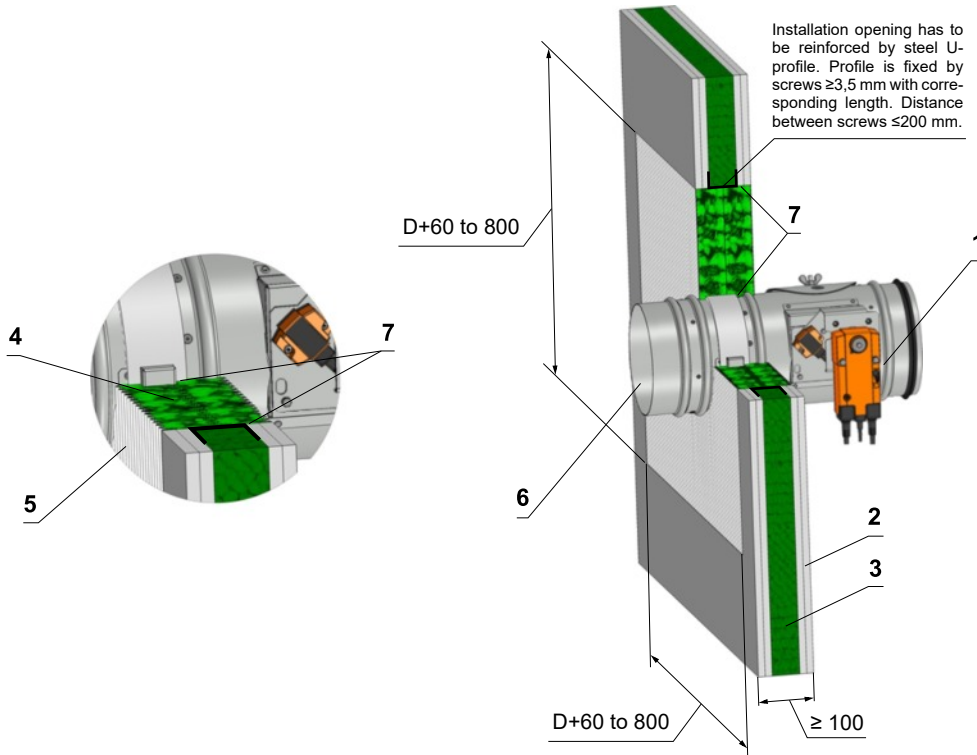

Position:

- 1 Fire damper
- 2 Gypsum plate
- 3 Mineral wool (type depending on the type of construction)
- 4 Fire resistant board
- 5 Fire stop coating thickness 1 mm
- 6 Duct
- 7 Fire resistant mastic - fill the gap on both sides of the fire separation construction and around the perimeter of penetration and damper body.

Used materials - example:

- 4 Hilti CFS-CT B 1S 140/50
- 5 Hilti CFS-CT
- 7 Hilti CFS-S ACR

Fig. 64 Gypsum wall construction - flange to flange - installation frame R1

EIS 90

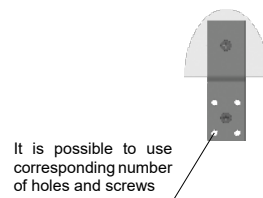
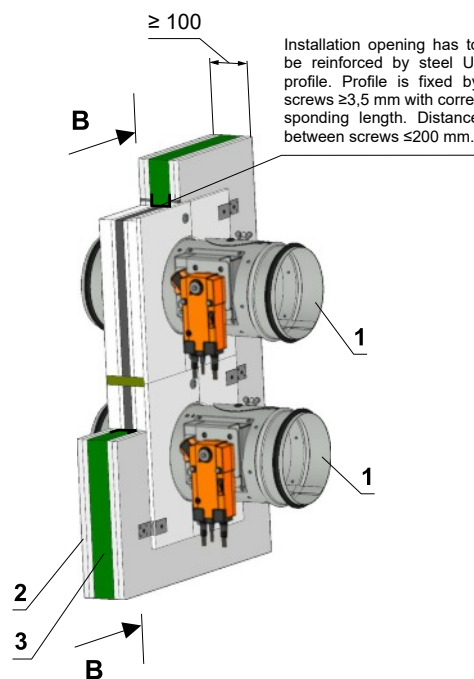
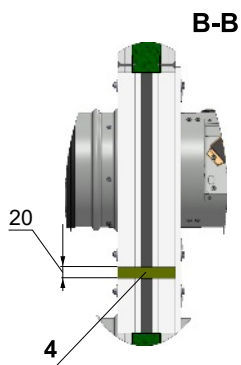
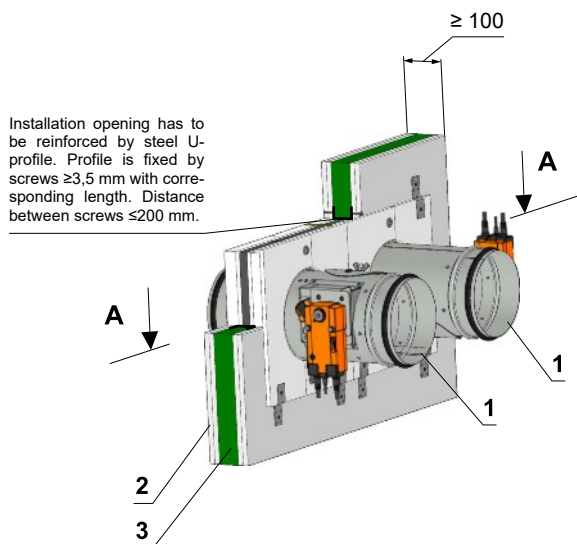
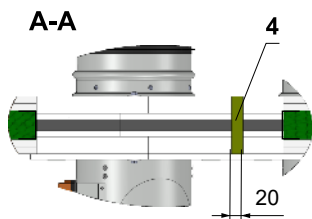

Position:

- 1 Fire damper with installation frame R1
- 2 Gypsum plate
- 3 Mineral wool (type depending on the type of construction)
- 4 Stuffing box (mineral stone wool min. density 140 kg/m³)

Notice:

- Gap between frame and damper body and frame and construction must be filled by glue (PROMAT K84).
- Distance between dampers 160 mm
- Flange to flange connection - Up to four dampers can be installed

Holders No. X = (2xZB1) + (2xZH1)
Screws No. Y = 2xX

Dimensions	Number ZB1	Number ZH1
D1 ≤ 400	1	1
400 < D1 ≤ 800	2	2
800 < D1 ≤ 1260	3	3
D1 ≤ 1600	4	4

D1 = D or D1 = 2xD

Fig. 65 Gypsum wall construction - flexible ceiling (with possibility to move/to sag) - installation frame R7

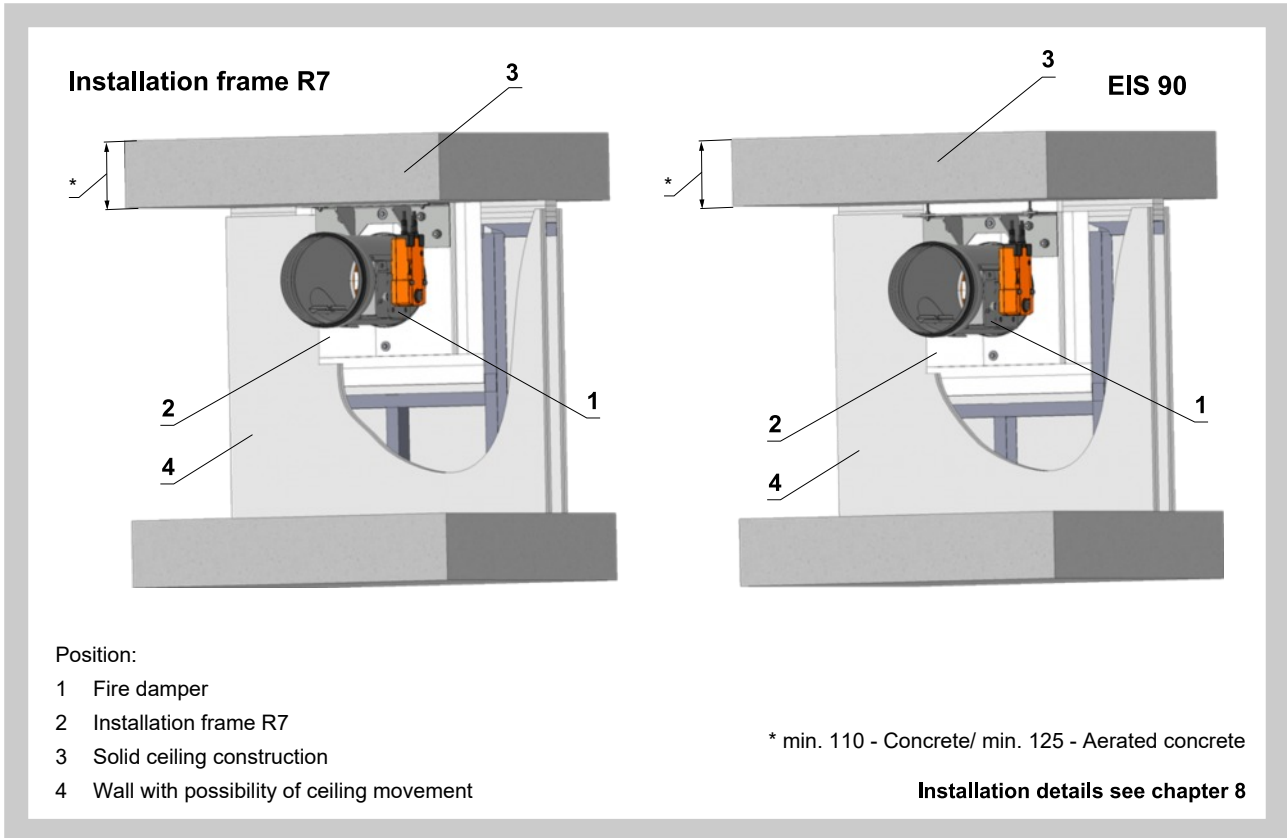
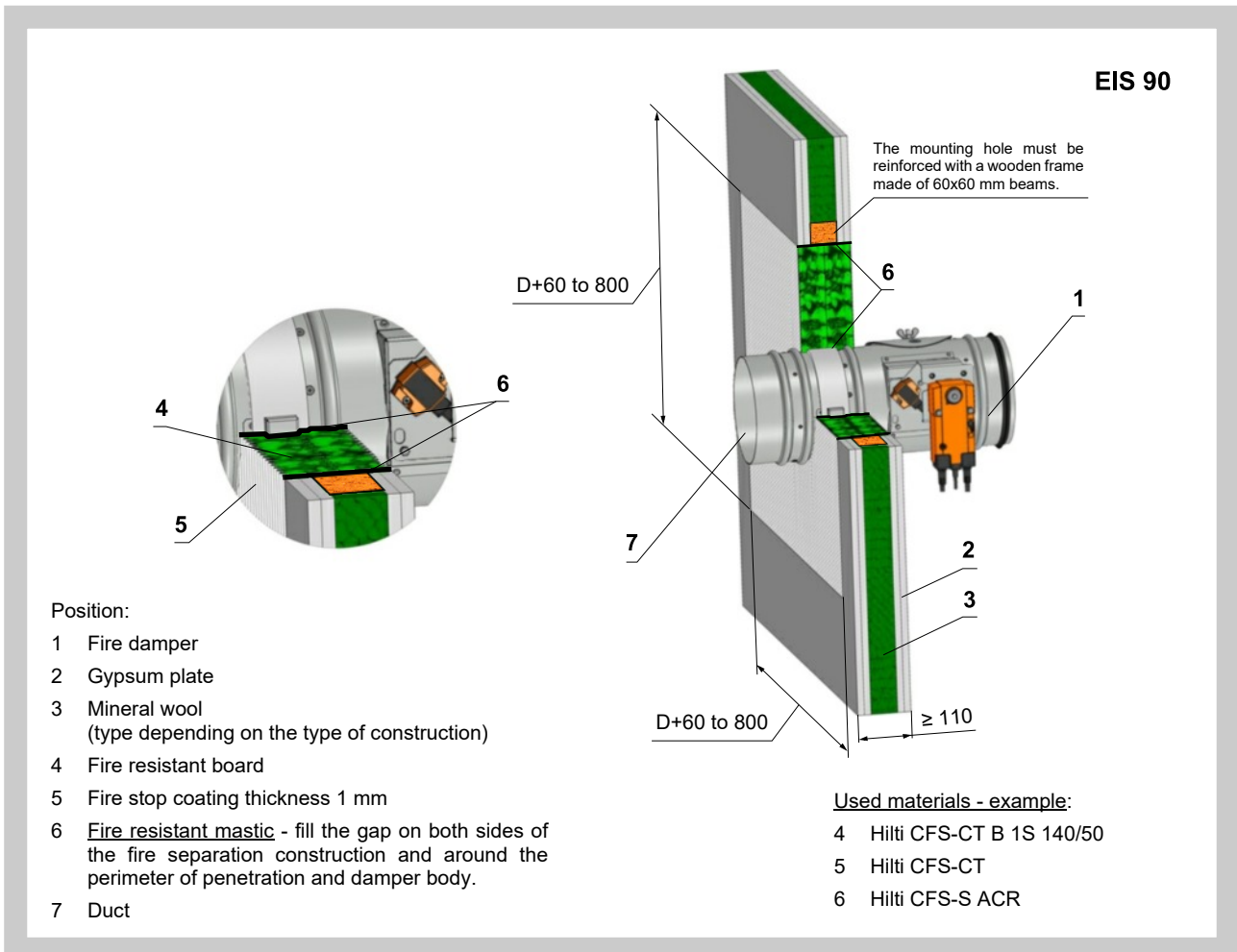

Fig. 66 Gypsum wall construction - with load-bearing construction of wooden beams min. cross-section 60x60 mm – Weichschott / Ablative Coated Batt



6.5. Installation outside gypsum wall construction

Fig. 67 Outside gypsum wall construction - mineral wool - mortar or gypsum

Minimum and maximum distance between the wall and fire damper when installation remote from the wall is unlimited.

EIS 90
EIS 60

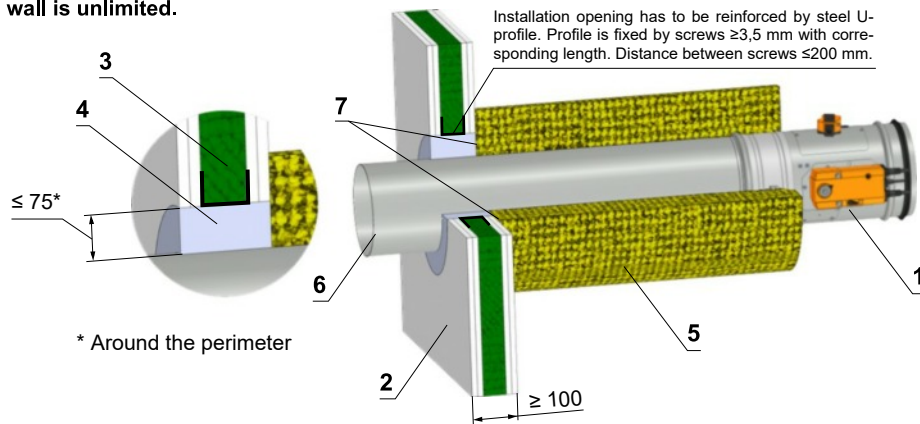

Position:

- 1 Fire damper
- 2 Gypsum plate
- 3 Mineral wool (type depending on the type of construction)
- 4 Mortar or gypsum
- 5 Stone wool with wired mat on one side, density 66 kg/m³
- 6 Duct
- 7 Apply ISOVER Protect BSK glue on the insulation and stick it to the fire separation construction ***

* Around the perimeter

Used materials - example:**

- 5 DN 100 ÷ DN 800 - System ISOVER_ULTIMATE PROTECT, th. 100 mm - EIS 60
- DN 100 ÷ DN 315 - System ISOVER_ULTIMATE PROTECT, th. 120 mm (2x60 mm) - EIS 90
- DN 350 ÷ DN 800 - System ISOVER_ULTIMATE PROTECT, th. 160 mm (100+60 mm) - EIS 90

** Insulation materials can be replaced by another approved fire sealing system with equivalent properties.
The maximum distance of the fire damper from the structure is not limited.

*** When installing the insulation, follow the ISOVER manufacturer's instructions.

The duct at the point of penetration does not have to be anchored to the fire wall construction, see chapter 9.

Fig. 68 Outside gypsum wall construction - mineral wool - stuffing box and fire protection mastic

Minimum and maximum distance between the wall and fire damper when installation remote from the wall is unlimited.

EIS 90
EIS 60

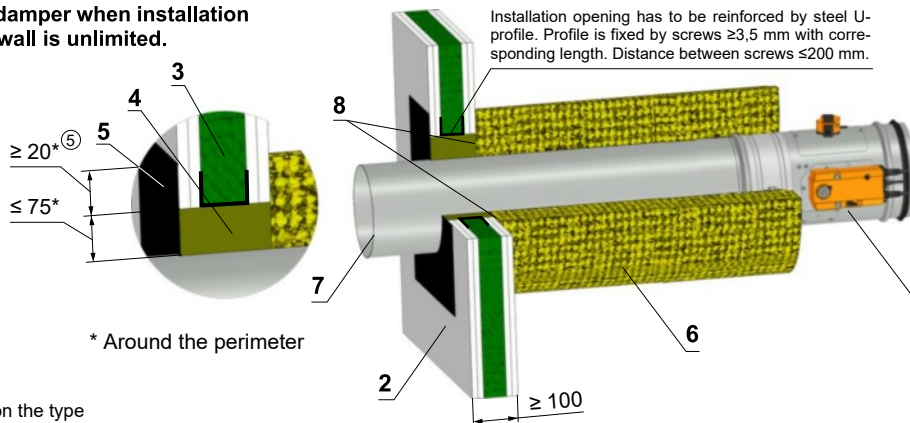

Position:

- 1 Fire damper
- 2 Gypsum plate
- 3 Mineral wool (type depending on the type of construction)
- 4 Stuffing box (mineral stone wool min. density 140 kg/m³)
- 5 Fire protection mastic min. thickness 1 mm
- 6 Stone wool with wired mat on one side, density 66 kg/m³
- 7 Duct
- 8 Apply ISOVER Protect BSK glue on the insulation and stick it to the fire separation construction ***

* Around the perimeter

Used materials - example:**

- 4 Promapyr, Rockwool Steprock HD, Hilti CFS-CT B 1S 140/50
- 5 Promastop - P, K, Hilti CFS-CT
- 6 DN 100 ÷ DN 800 - System ISOVER_ULTIMATE PROTECT, th. 100 mm - EIS 60
- DN 100 ÷ DN 315 - System ISOVER_ULTIMATE PROTECT, th. 120 mm (2x60 mm) - EIS 90
- DN 350 ÷ DN 800 - System ISOVER_ULTIMATE PROTECT, th. 160 mm (100+60 mm) - EIS 90

** Insulation materials can be replaced by another approved fire sealing system with equivalent properties.
The maximum distance of the fire damper from the structure is not limited.

*** When installing the insulation, follow the ISOVER manufacturer's instructions.

The duct at the point of penetration must be anchored to the fire wall construction, see chapter 9.

Fig. 69 Outside of gypsum wall construction - mineral wool, stuffing box, fire protection mastic and cement lime plate

Minimum and maximum distance between the wall and fire damper when installation remote from the wall is unlimited.

EIS 90

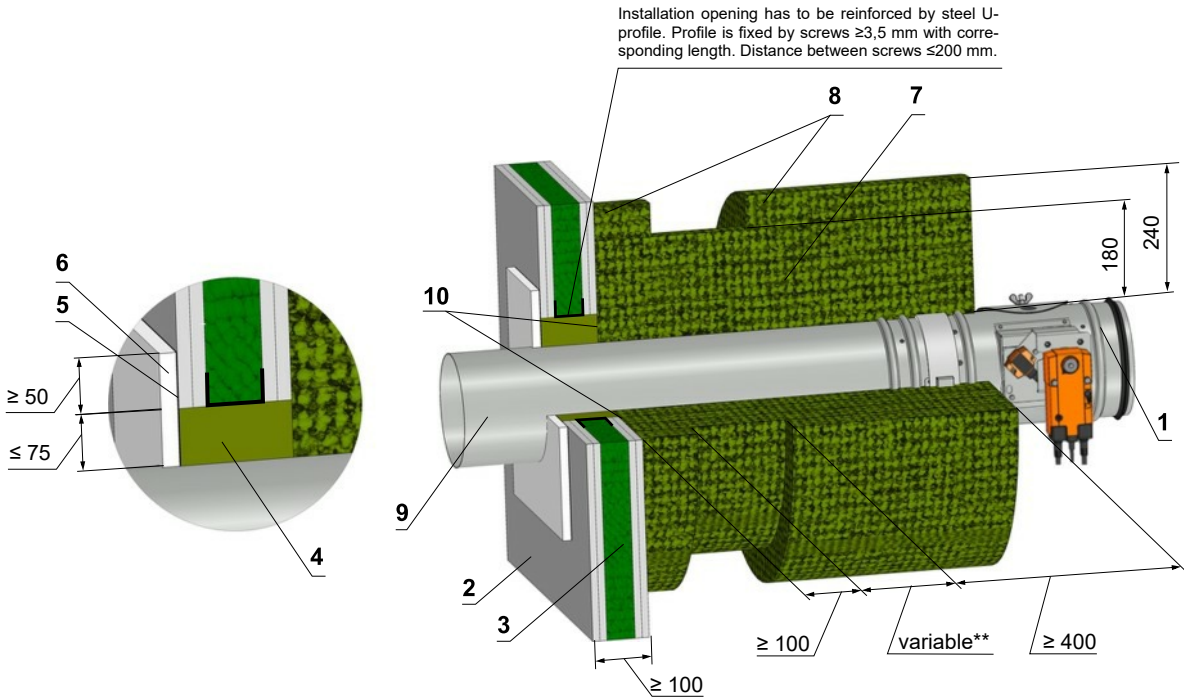

Ensure symmetry with rod location

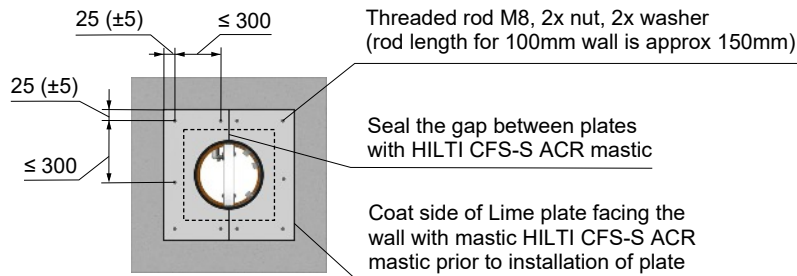

Screws has to be fixed in wall/ceiling construction.
(If it is needed use steel bracket).

Position:

- 1 Fire damper
- 2 Gypsum plate
- 3 Mineral wool (type depending on the type of construction)
- 4 Stuffing box (mineral stone wool min. density 140 kg/m³)
- 5 Fire protection mastic min. thickness 1 mm
- 6 Cement lime plate min. thickness 15 mm (min. density 870 kg/m³)
- 7 Stone wool with one side stitched wire fencing (min. density 105 kg/m³, thickness 180 mm (e.g. 3x60 mm)
- 8 Stone wool with one side stitched wire fencing (min. density 105 kg/m³, thickness 60 mm)
- 9 Duct
- 10 Apply Rockwool Firepro glue on the insulation and stick it to the fire separation construction ***

Used materials - example:*

- 3 Promapyr, Rockwool Steprock HD, Hilti CFS-CT B 1S 140/50
- 4 Promapyr. Rockwool Steprock HD. Hilti CFS-CT C 1S 140/50
- 5 Promastop - P, K, Hilti CFS-CT
- 6 Promatect - H
- 7 Rockwool Wired Mat 105 th. 3x60 mm
- 8 Rockwool Wired Mat 105 th. 60 mm

* Stuffing box, fire protection mastic, cement lime plate and insulation materials can be replaced by another approved fire sealing system for damper installation with equivalent material properties.

** Depends on the distance of the flap from the construction, when the maximum distance from the construct is not limited and according to EN 15882-2 must use the required number of hinges according to EN 13366-1:2014.

*** When installing the insulation, follow the Rockwool manufacturer's instructions.

The duct at the point of penetration must be anchored to the fire wall construction, see chapter 9.

6.6. Installation in solid ceiling construction

Fig. 70 Solid ceiling construction - mortar or gypsum

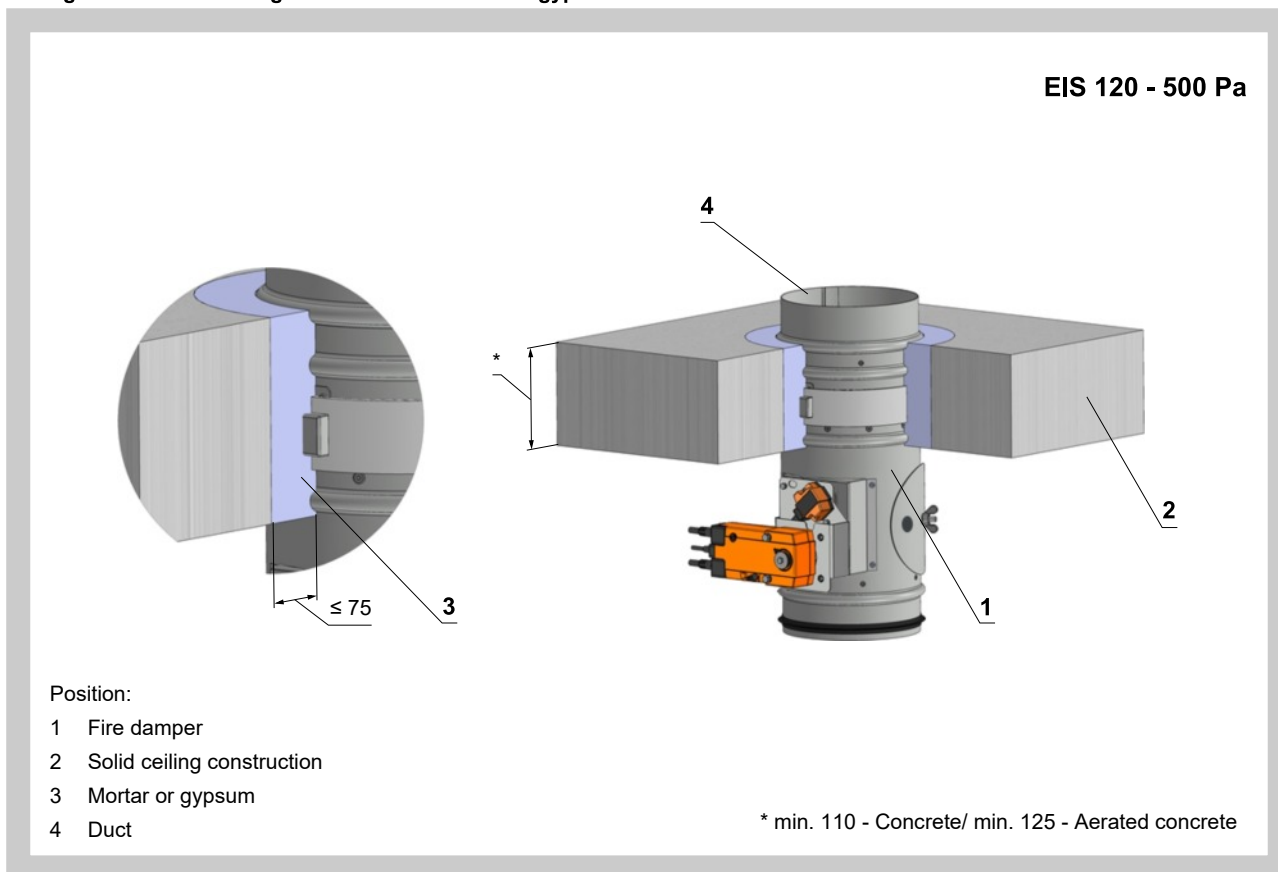

Fig. 71 Solid ceiling construction - stuffing box and fire protection mastic

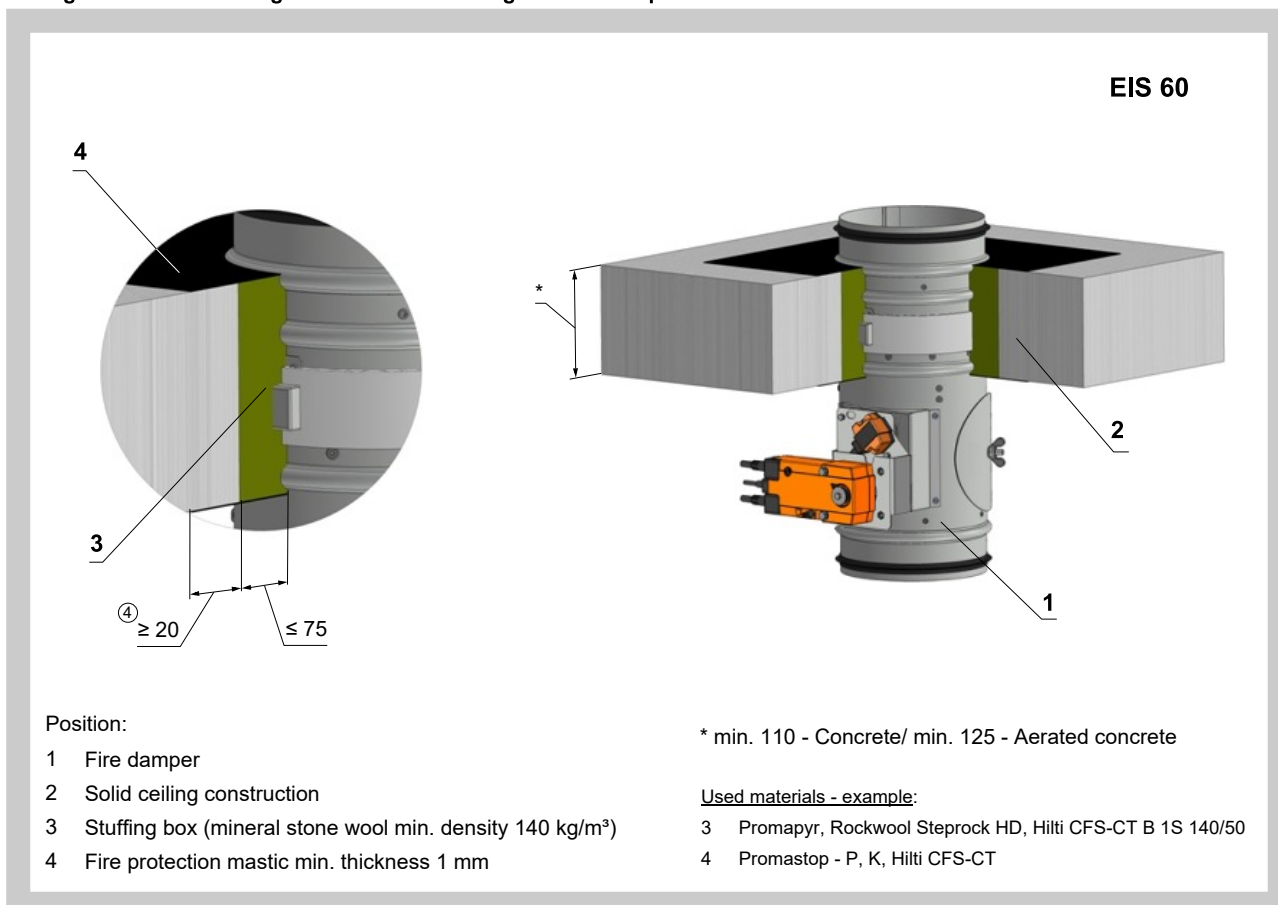
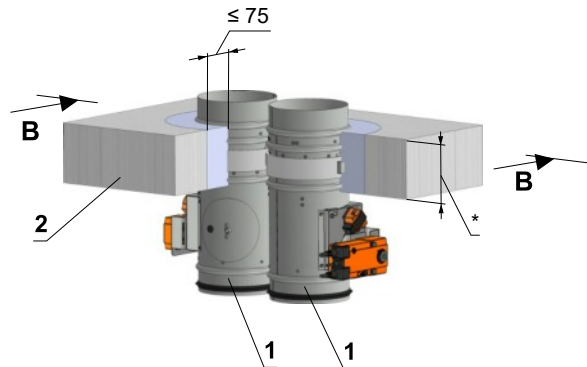
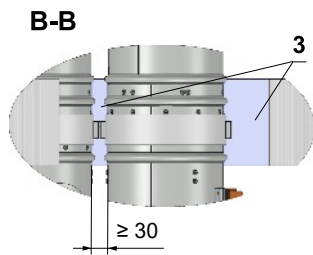
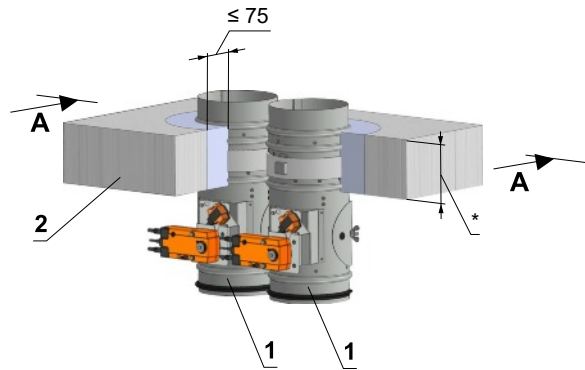
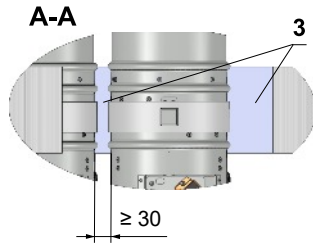

Fig. 72 Solid ceiling construction - flange to flange - mortar or gypsum

EIS 90



* min. 110 - Concrete/ min. 125 - Aerated concrete

Position:

- 1 Fire damper
- 2 Solid wall construction
- 3 Mortar or gypsum

Notice:

- Installation opening for each damper has minimal dimensions D+80 mm (D+160 mm for dampers with flanges)
- Gap between damper and construction is filled by mortar or gypsum
- Distance between dampers 70 mm
- Flange to flange connection - Up to four dampers can be installed

Fig. 73 Solid ceiling construction - stuffing box, fire protection mastic and cement lime plate

EIS 90

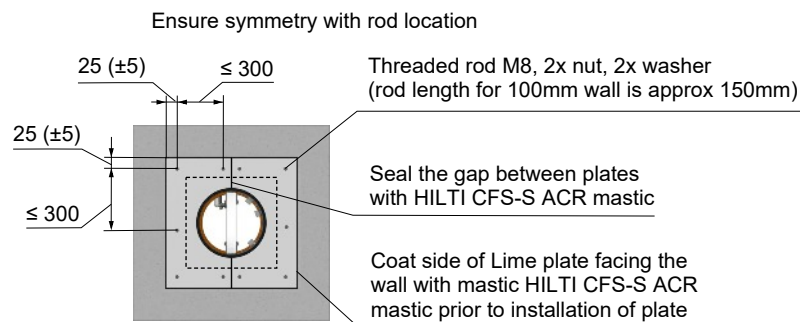
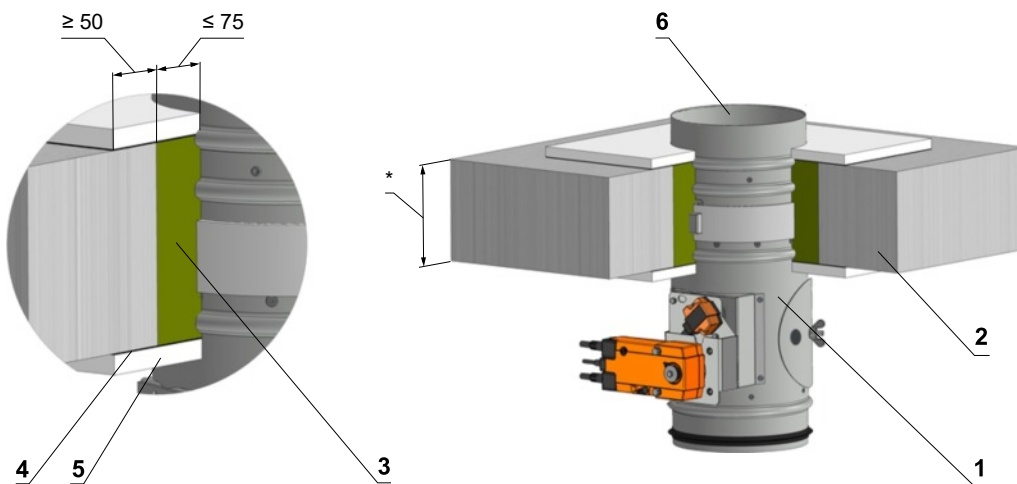

Screws has to be fixed in wall/ceiling construction.
(If it is needed use steel bracket).

* min. 110 - Concrete/ min. 125 - Aerated concrete

Used materials - example:

- 3 Promapyr, Rockwool Steprock HD, Hilti CFS-CT B 1S 140/50
- 4 Promastop - P, K, Hilti CFS-CT
- 5 Promatect - H

Position:

- 1 Fire damper
- 2 Solid ceiling construction
- 3 Stuffing box (mineral stone wool min. density 140 kg/m³)
- 4 Fire protection mastic min. thickness 1 mm
- 5 Cement lime plate min. thick. 15 mm min. density 870 kg/m³
- 6 Duct

Fig. 74 Solid ceiling construction - stuffing box with fire protection mastic and coating

EIS 90

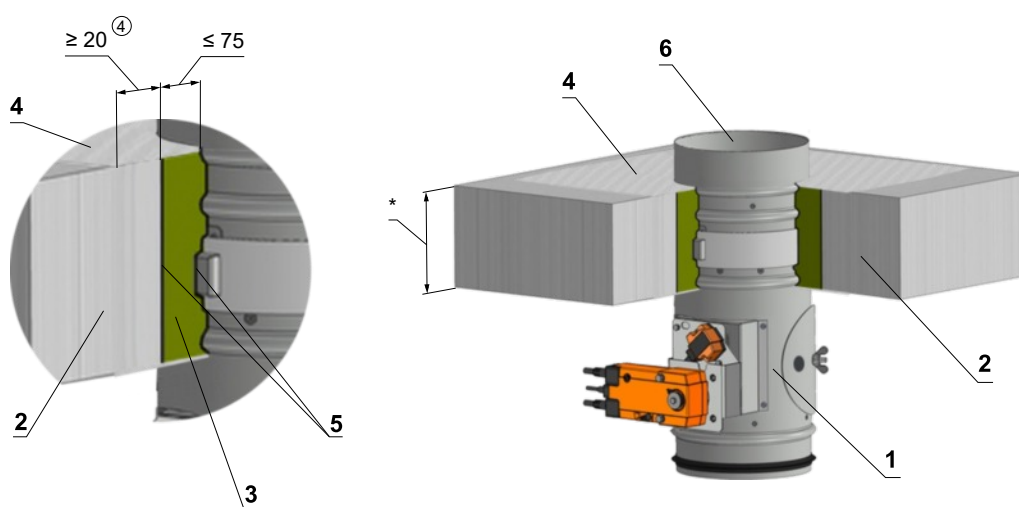

Position:

- 1 Fire damper
- 2 Solid ceiling construction
- 3 Stuffing box (mineral stone wool min. density 150 kg/m³)
- 4 Fire protection coating th. 1 mm
- 5 Fire protection mastic th. 1 mm
- 6 Duct

* min. 110 - Concrete/ min. 125 - Aerated concrete

Used materials - example:

- 3 HILTI CFS-CT B 1S 140/50 or
ROCKWOOL HARDROCK + coating HILTI CFS-CT
- 4 HILTI CFS-CT
- 5 HILTI CFS-S ACR

Fig. 75 Solid ceiling construction - installation frame R1, R2, R3, R4, R5

EIS 90

Installation frame R1, R2

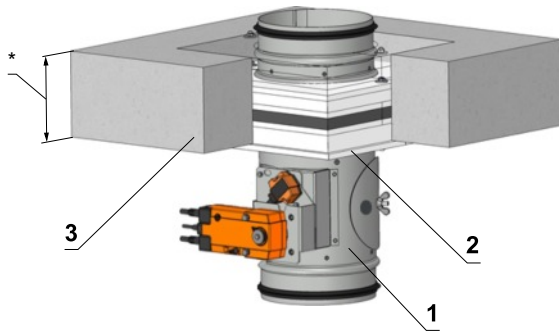

Installation frame R3, R4

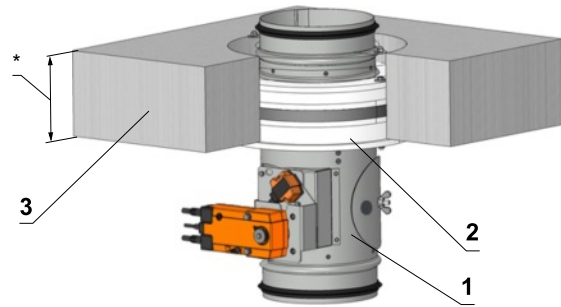

Installation frame R5 (DN 100 - 200)

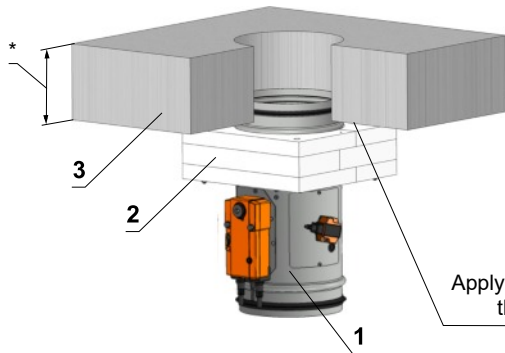

Installation frame R5 (DN 225 - 800)

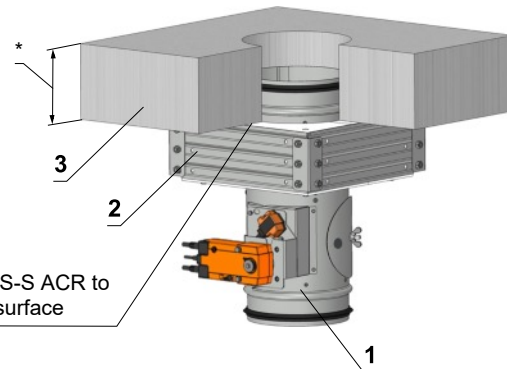

Position:

- 1 Fire damper
- 2 Installation frame
- 3 Solid ceiling construction

* min. 110 - Concrete/ min. 125 - Aerated concrete

Installation details see chapter 8

Fig. 76 Solid ceiling construction - Weichschott / Ablative Coated Batt

EIS 90

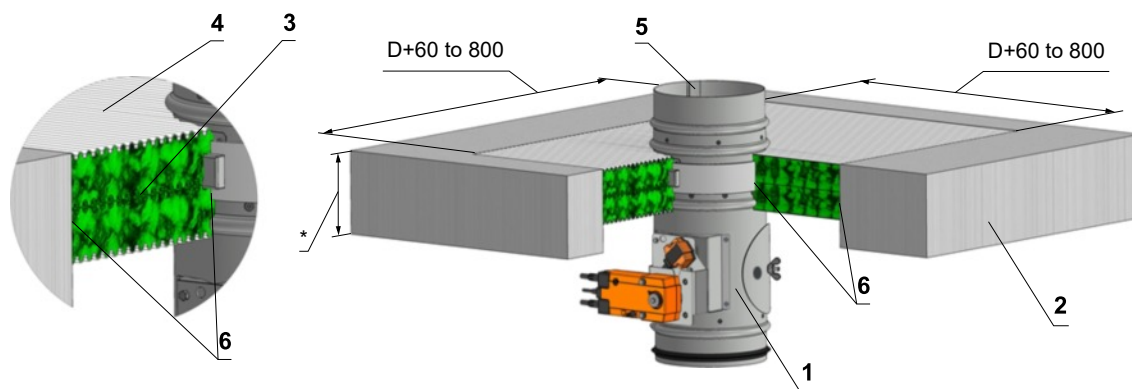

Position:

- 1 Fire damper
- 2 Solid ceiling construction
- 3 Fire resistant board
- 4 Fire stop coating thickness 1 mm
- 5 Duct
- 6 Fire resistant mastic - fill the gap on both sides of the fire separation construction and around the perimeter of penetration and damper body.

* min. 110 - Concrete/ min. 125 - Aerated concrete

Used materials - example:

- 3 Hilti CFS-CT B 1S 140/50
- 4 Hilti CFS-CT
- 6 Hilti CFS-S ACR

Fig. 77 Solid ceiling construction - flange to flange - installation frame R2

EIS 90

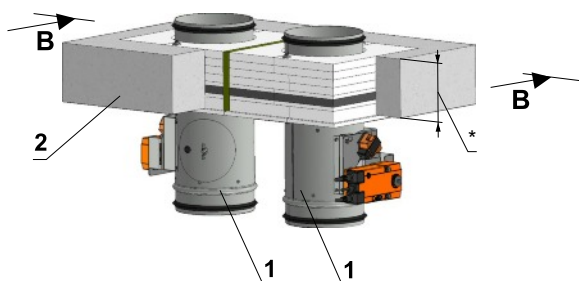
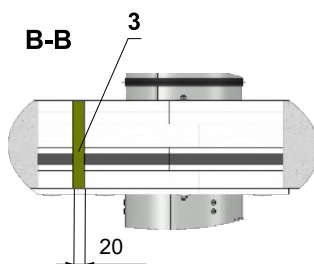
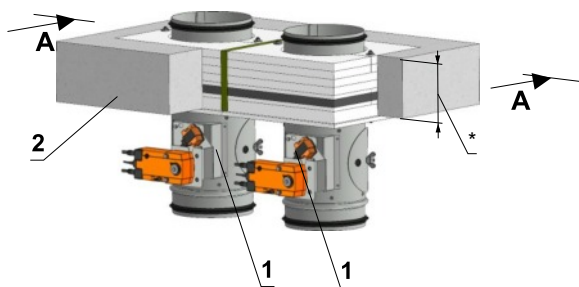
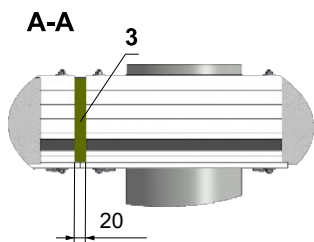

* min. 110 - Concrete/ min. 125 - Aerated concrete

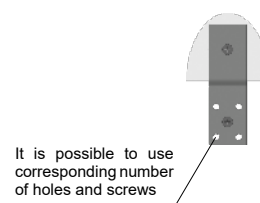

It is possible to use corresponding number of holes and screws

Holders No. X = (2xZB1) + (2xZH1)
Screws No. Y = 2xX

Dimensions	Number ZB1	Number ZH1
D1 ≤ 400	1	1
400 < D1 ≤ 800	2	2
800 < D1 ≤ 1260	3	3
D1 ≤ 1600	4	4

D1 = D or D1 = 2xD

Position:

- 1 Fire damper with installation frame R2
- 2 Solid wall construction
- 3 Mineral stone wool min. density 140 kg/m³

Notice:

- Gap between frame and damper body and frame and construction must be filled by glue (PROMAT K84).
- Distance between dampers 160 mm
- Flange to flange connection - Up to four dampers can be installed

6.7. Installation outside solid ceiling construction

Fig. 78 Outside solid ceiling construction - mineral wool - mortar or gypsum

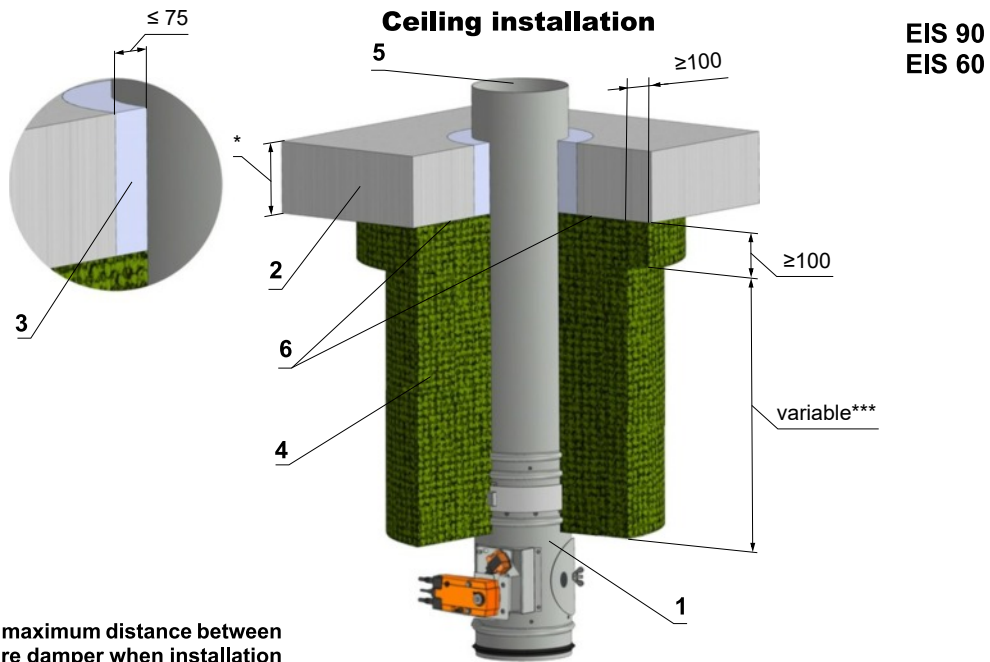

Minimum and maximum distance between the wall and fire damper when installation remote from the wall is unlimited.

* min. 110 - Concrete/ min. 125 - Aerated concrete

Floor installation

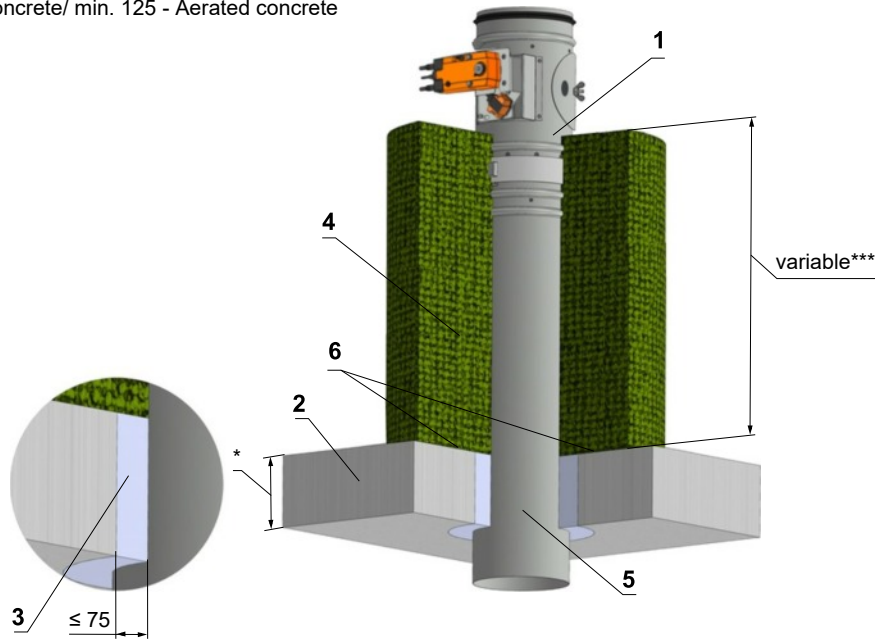

Position:

- 1 Fire damper
- 2 Solid ceiling construction
- 3 Mortar or gypsum
- 4 Stone wool with wired mat on one side, density 66 kg/m³
- 5 Duct
- 6 Apply Rockwool Firepro glue on the insulation and stick it to the fire separation construction ****

Used materials - example:**

- 4 DN 100 ÷ DN 800 - System ISOVER_ULTIMATE PROTECT, th. 100 mm - EIS 60
- DN 100 ÷ DN 315 - System ISOVER_ULTIMATE PROTECT, th. 120 mm (2x60 mm) - EIS 90
- DN 350 ÷ DN 800 - System ISOVER_ULTIMATE PROTECT, th. 160 mm (100+60 mm) - EIS 90

** Stuffing box, fire protection mastic, cement lime plate and insulation materials can be replaced by another approved fire sealing system for damper installation with equivalent material properties.

*** Depends on the distance of the flap from the construction, when the maximum distance from the construct is not limited and according to EN 15882-2 must use the required number of hinges according to EN 13366-1:2014.

**** When installing the insulation, follow the Rockwool manufacturer's instructions.

The duct at the point of penetration does not have to be anchored to the fire wall construction, see chapter 9.

Fig. 79 Outside solid ceiling construction - mineral wool - mortar or gypsum

Minimum and maximum distance between the wall and fire damper when installation remote from the wall is unlimited.

EIS 90

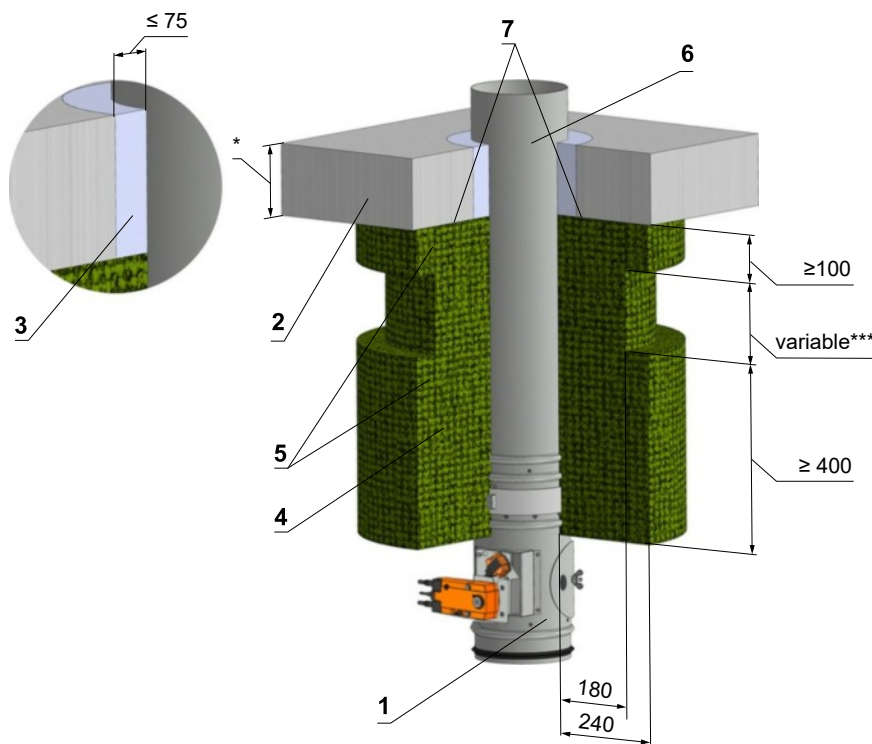

* min. 110 - Concrete/ min. 125 - Aerated concrete

Used materials - example:**

- 4 Rockwool Wired Mat 105 th. 3x60 mm
- 5 Rockwool Wired Mat 105 th. 60 mm

** Stuffing box, fire protection mastic, cement lime plate and insulation materials can be replaced by another approved fire sealing system for damper installation with equivalent material properties.

*** Depends on the distance of the flap from the construction, when the maximum distance from the construct is not limited and according to EN 15882-2 must use the required number of hinges according to EN 13366-1:2014.

Position:

- 1 Fire damper
- 2 Solid ceiling construction
- 3 Mortar or gypsum
- 4 Stone wool with one side stitched wire fencing (min. density 105 kg/m³), thickness 180 mm (e.g. 3x60 mm)
- 5 Stone wool with one side stitched wire fencing (min. density 105 kg/m³), thickness 60 mm
- 6 Duct
- 7 Apply Rockwool Firepro glue on the insulation and stick it to the fire separation construction ****

**** When installing the insulation, follow the Rockwool manufacturer's instructions.

The duct at the point of penetration does not have to be anchored to the fire wall construction, see chapter 9.

Fig. 80 Installation outside of solid ceiling construction - concrete

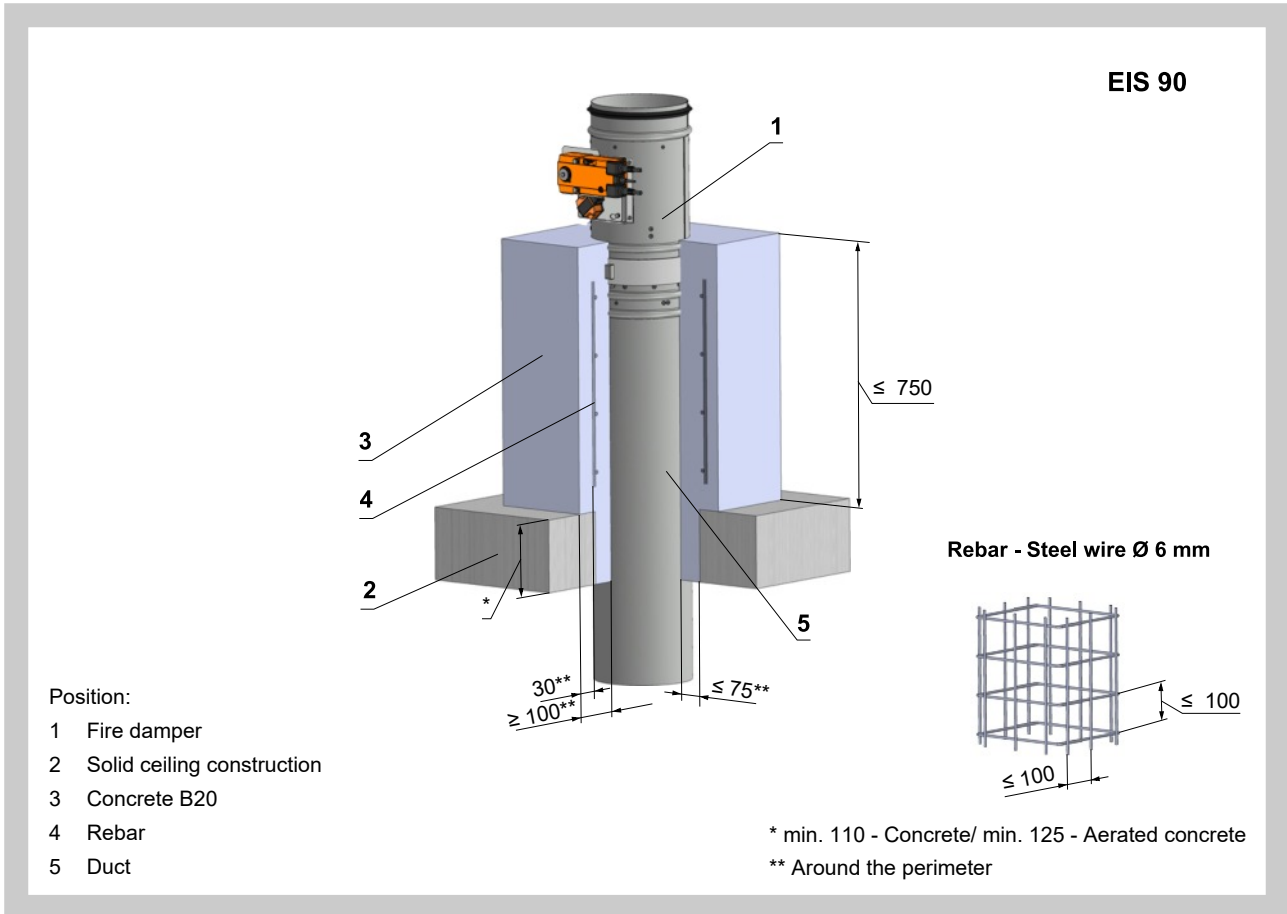

Fig. 81 Installation outside of solid ceiling construction - concrete and installation frame R5

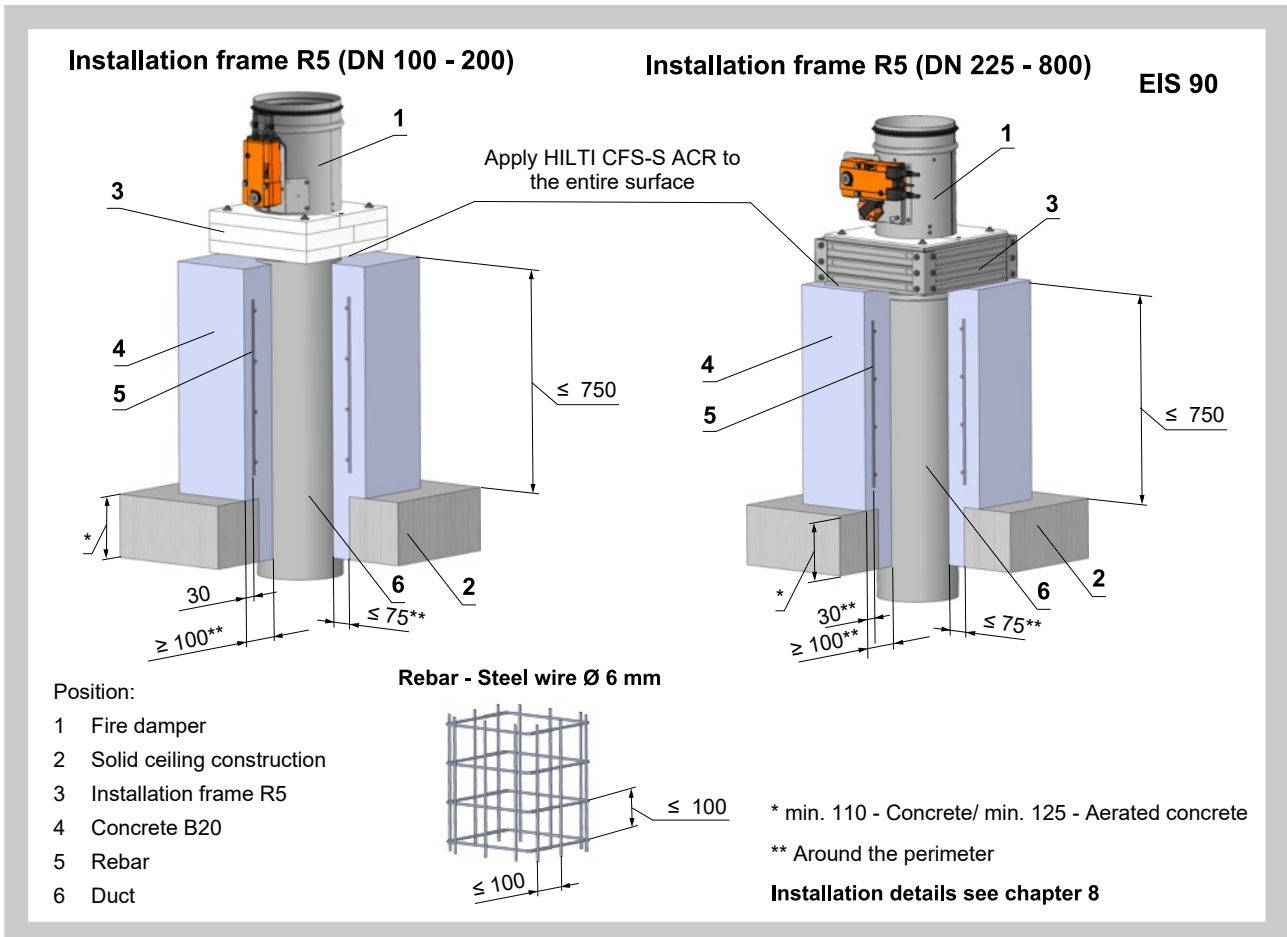
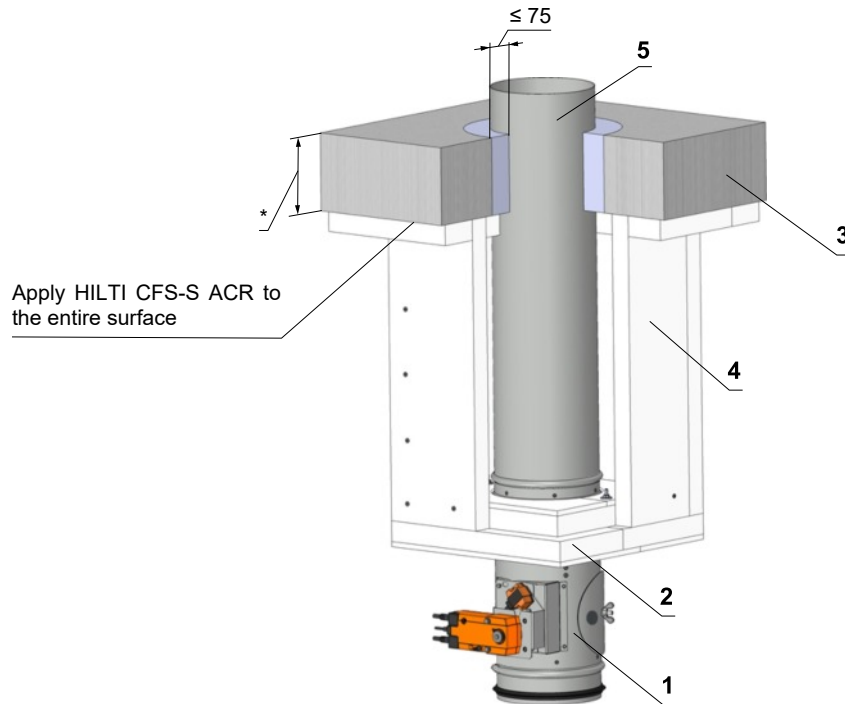

Fig. 82 Installation outside of solid ceiling construction - installation frame R6 with cement lime plates

Installation frame R6

EIS 90

Minimum and maximum distance between the wall and fire damper when installation remote from the wall is unlimited.



Position:

- 1 Fire damper
- 2 Installation frame R6
- 3 Solid ceiling construction
- 4 Cement lime plate - all parts are glued with glue Promat K84 and secured by screws.
- 5 Duct

* min. 110 - Concrete/ min. 125 - Aerated concrete

Installation details see chapter 8.

6.8. Installation in sandwich wall construction

Fig. 83 Sandwich wall construction - stuffing box and fire protection mastic, coating and cement lime plate

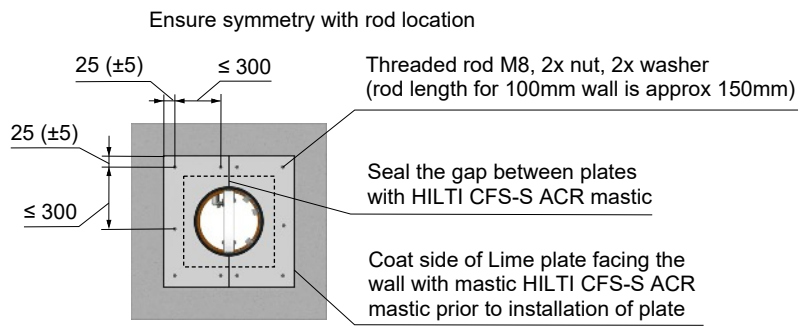
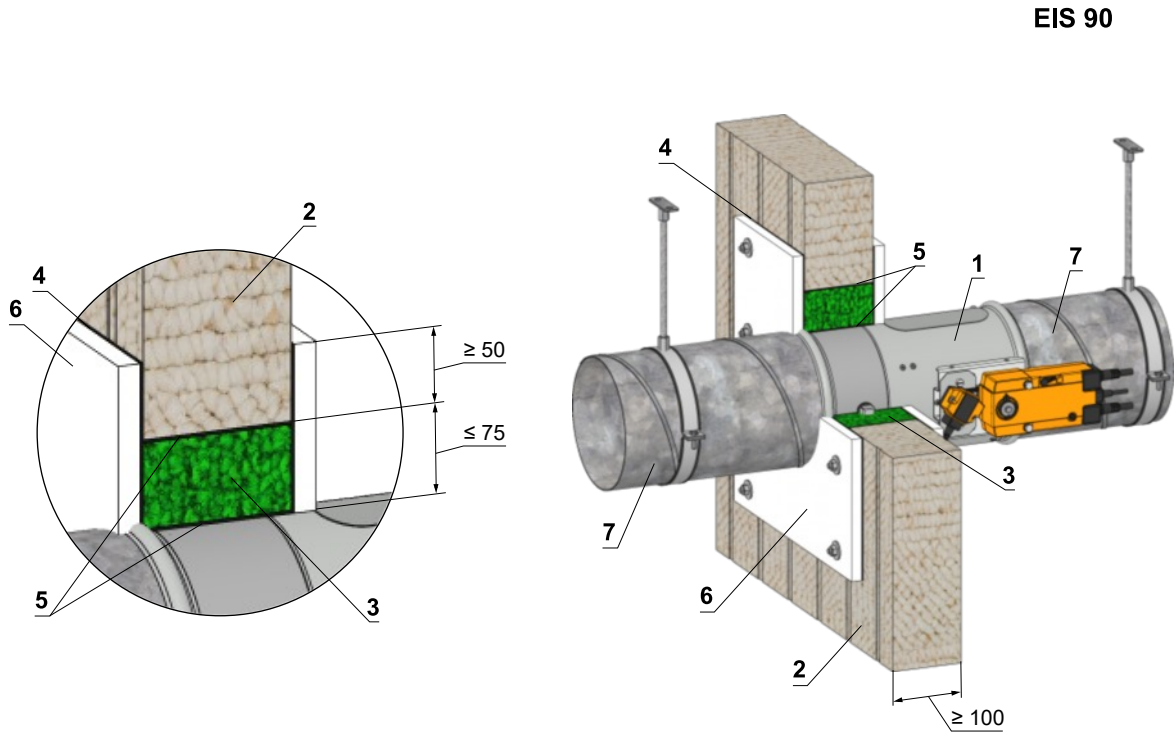

Screws has to be fixed in wall/ceiling construction.
(If it is needed use steel bracket).

Position:

- 1 Fire damper
- 2 Sandwich wall construction
- 3 Stuffing box (mineral stone wool min. density 140 kg/m³)
- 4 Fire protection coating th. 1 mm
- 5 Fire protection mastic th. 1 mm
- 6 Cement lime plate min. thickness 15 mm min. density 870 kg/m³
- 7 Duct

Used materials - example:

- 2 Paroc AST S th. 100 mm or RUUKKI SPB W th. 100 mm
- 3 Promapyr, Rockwool Steprock HD, Hilti CFS-CT B 1S 140/50
- 4 Promastop - P, K, Hilti CFS-CT
- 5 HILTI CFS-S ACR

7. Thin shaft walls

Thin shaft wall description

Shaft wall is a vertical, non-bearing partition construction meeting the double-sided fire requirements. The shaft wall can be mounted only from one side. No mineral insulation is used in the construction.

First of all, the shaft wall structure must be laid out. Apart from other vertical constructions, the perimeter sections must be fitted with connection sealing made from A1 or A2 fire reaction materials (for instance floor strips Orsil N/PP). The perimeter sections must be anchored using steel plugs Ø 6 mm (for example DN6 or ZHOP) with 500 mm span.

Sheathing is carried out using two layers of Glasroc F boards Ridurit with 20 mm thickness, the boards are oriented horizontally. First sheathing layer is fixed with TN 212 screws in spacing 200mm to the support structure. The boards are mounted to tight butt joints without need of cementing. The second sheathing layer is screwed to the first sheathing layer using screws Rodurit in square net 250 mm. Reset of joints of the first and second layer of Ridurit sheathing is set to 600 mm vertically and 300 mm horizontally.

Assembly with support structure

Vertical intermediate R-CW sections are fixed in 1000 mm layout spacing between R-UW sections and vertical perimeter R-CW sections.

Assembly without support structure

Maximum width of the shaft wall is 2 metres in this case (board length). Steel squares made from steel galvanized plate metal 40/20/1 mm are used as perimeter sections, they are anchored to bearing wall using Ø 6 mm steel plugs (for example DN6 or ZHOP) with 500 mm spacing.

Fig. 84

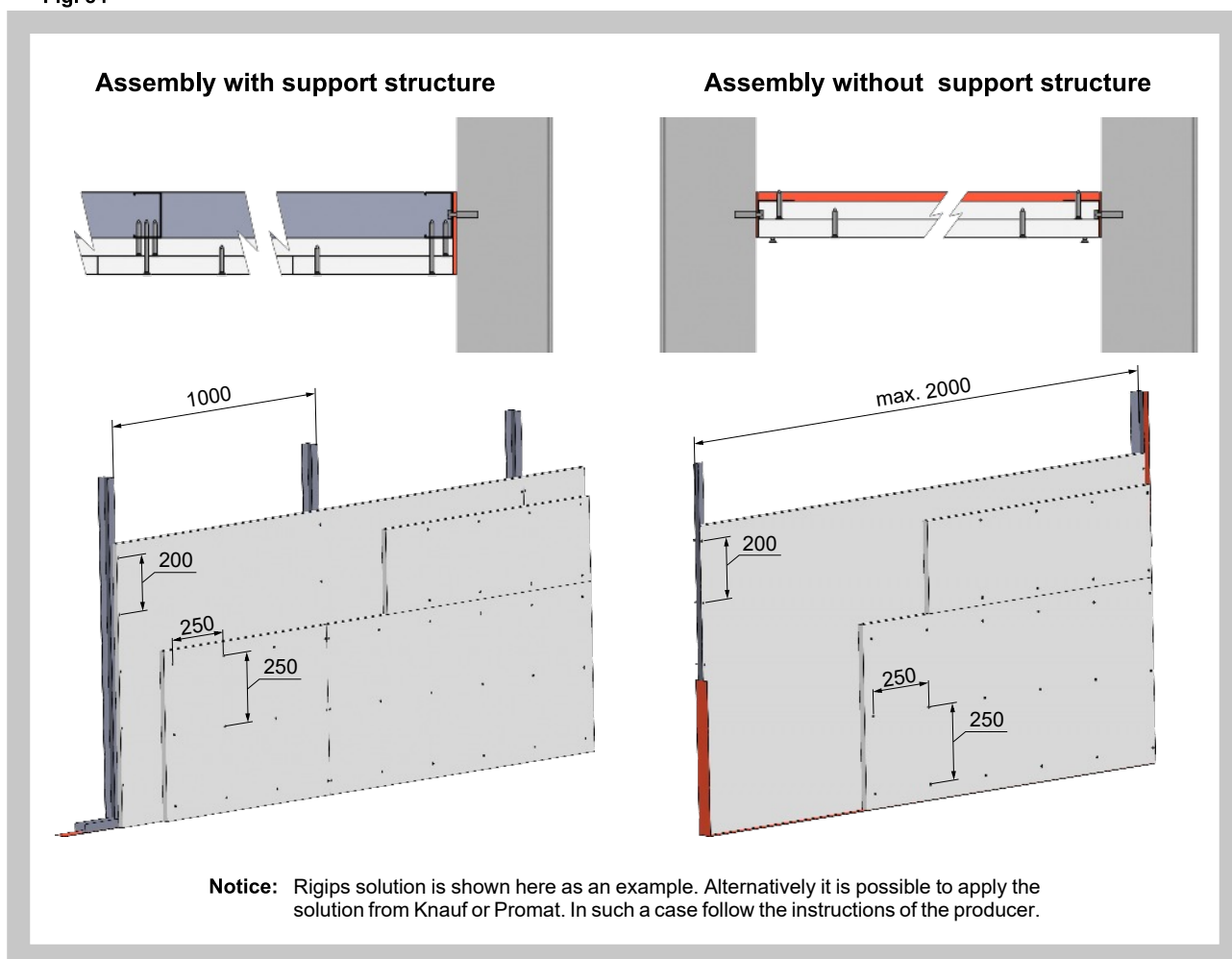
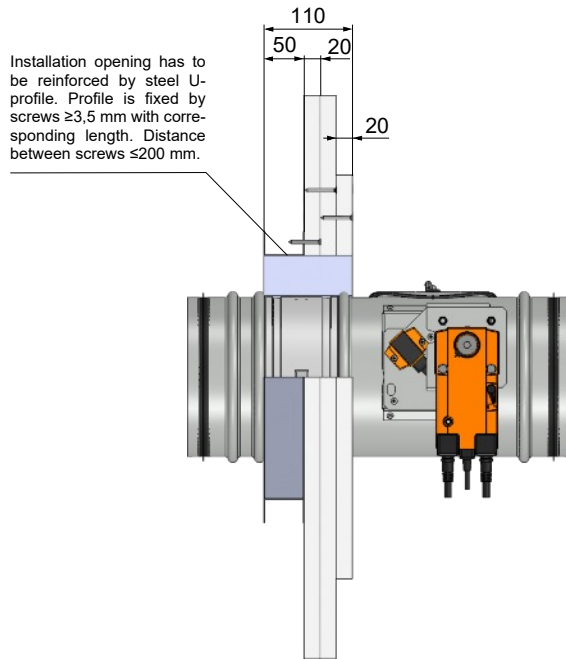
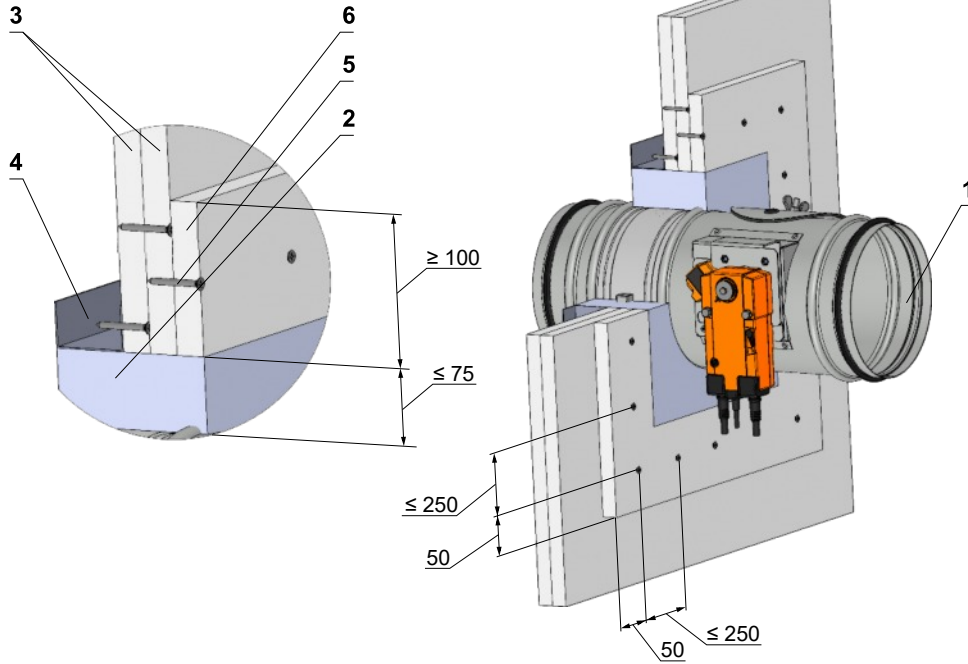

Fig. 85 Thin shaft wall - mortar or gypsum

EIS 90



Installation opening:

$$a \times b = (D + 100 \text{ mm}) \times (D + 100 \text{ mm})$$

Alternatively solution of installation opening

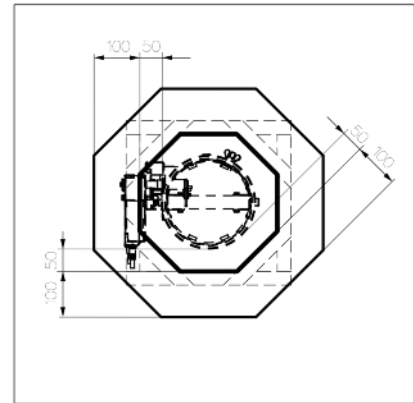

Position:

- 1 Fire damper
- 2 Mortar or gypsum
- 3 Fire resistant board
- 4 Steel U-profile
- 5 Screw
- 6 Additional fire resistant board

Used materials - example:*

- 3 Glasroc F Ridurit th. 20 mm
- 4 Steel U-profile 50
- 5 Screw Ridurit
- 6 Glasroc F Ridurit th. 20 mm

* It is alternatively possible to use Knauf or Promat solution.

Fig. 86 Thin shaft wall - installation frame R1

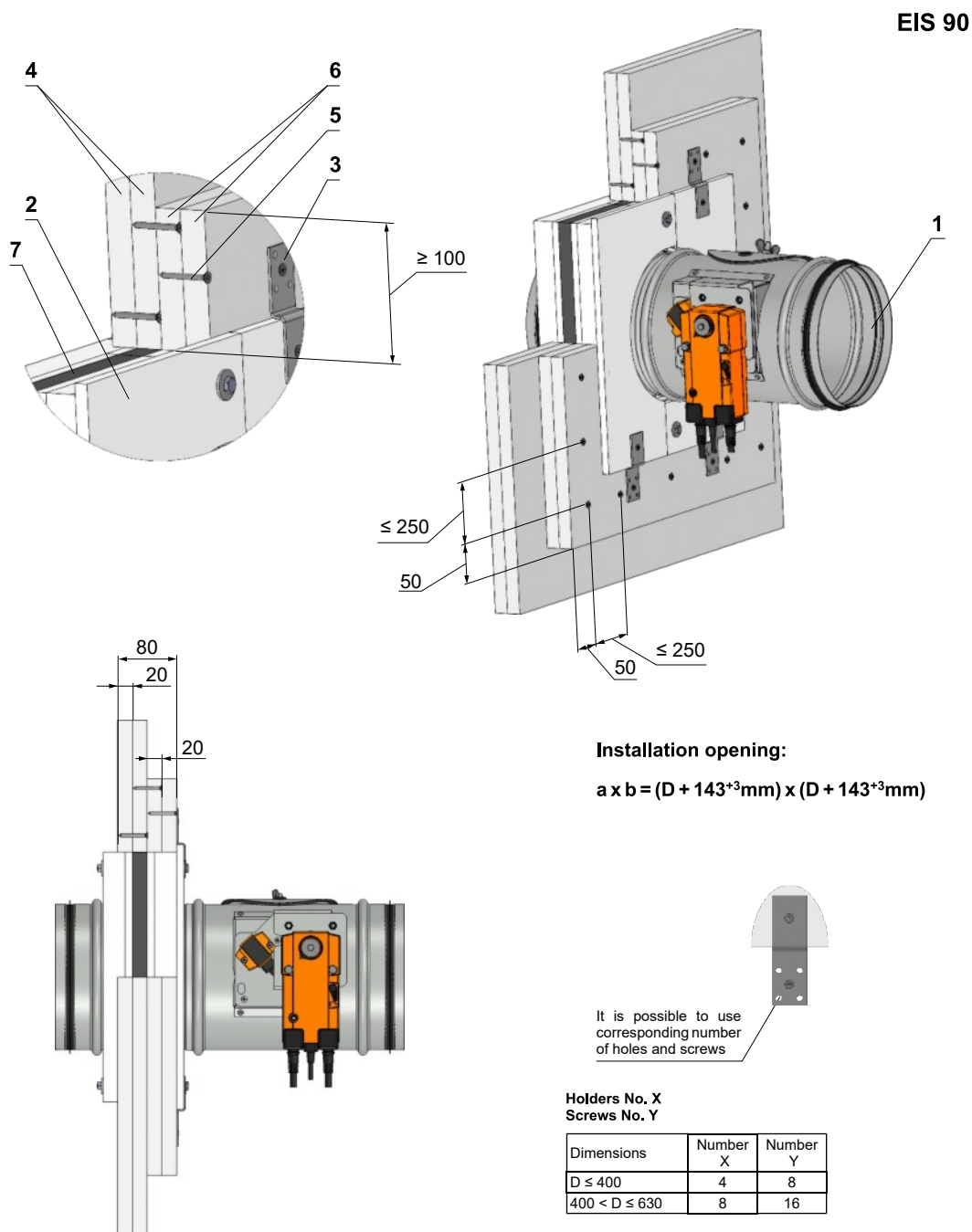

Position:

- 1 Fire damper
- 2 Installation frame R1
- 3 Holder (including in installation frame R1 packing)
- 4 Fire resistant board
- 5 Screw
- 6 Additional fire resistant board
- 7 Fire resistant foam tape

Used materials - example:*

- 4 Glasroc F Ridurit th. 20 mm
- 5 Screw Ridurit
- 6 Glasroc F Ridurit th. 20 mm
- 7 Promaseal XT

* It is alternatively possible to use Knauf or Promat solution.

Notice: Gap between frame and thin shaft wall construction must be filled by glue (PROMAT K84).
 Dampers has to be suspended in an appropriate manner see chapter 9

8. Installation frames

Tab. 8.1.1 List of installation frames and installation options

Frame / Material	Wall thickness [mm]								
	Solid wall construction			Solid ceiling construction			Plasterboard construction		
	In construction	Outside construction	On construction	In construction	Outside construction	On construction	In construction	Outside construction	On construction
R1 / Cement lime	≥100	-	-	≥110 / 125	-	-	≥100	-	-
R2 / Cement lime	≥110 / 125	-	-	≥110 / 125	-	-	≥100	-	-
R3 / Cement lime	≥100	-	-	≥110 / 125	-	-	≥100	-	-
R4 / Cement lime	≥110 / 125	-	-	≥110 / 125	-	-	≥100	-	-
R5* / Cement lime	-	-	≥100	-	≥110 / 125**	≥110 / 125	-	-	≥100
R6 / Cement lime	-	≥100	-	-	≥110 / 125	-	-	-	-
R7 / Cement lime	-	-	-	-	-	-	≥100***	-	-

*Only for SPIRO design (without flanges)

**With concrete

***Ceiling with movement possibility

Fig. 87 Installation frame R1, R2, R3, R4

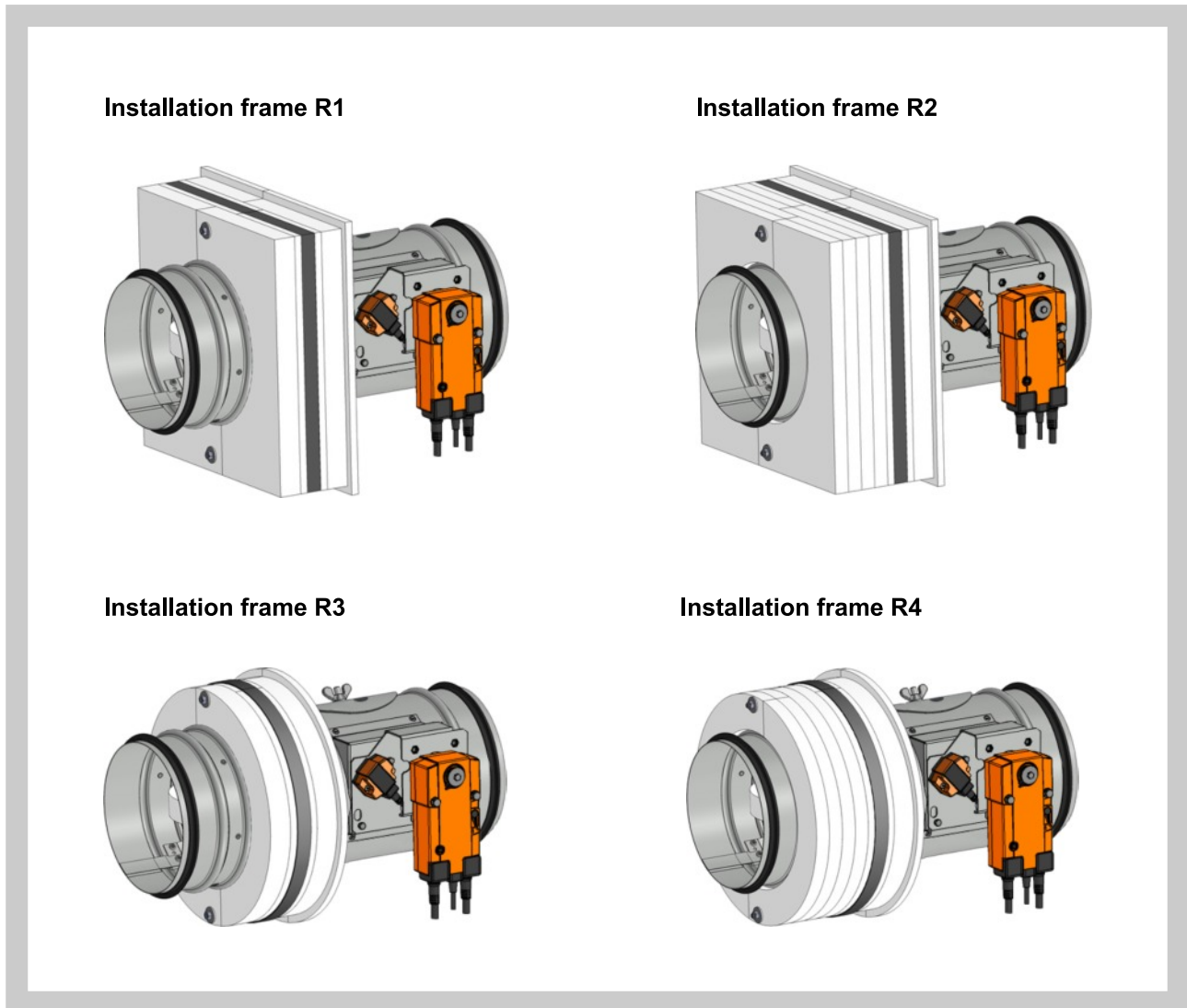
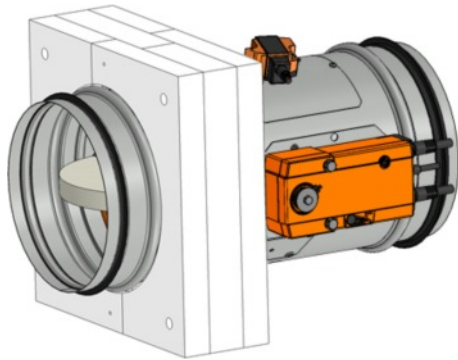
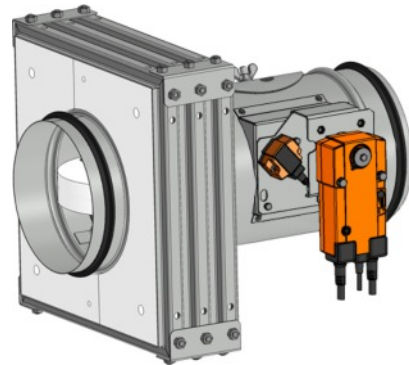

Fig. 88 Installation frame R5, R6, R7

Installation frame R5 (DN 100 - 200)



Installation frame R5 (DN 225 - 800)



Installation frame R6

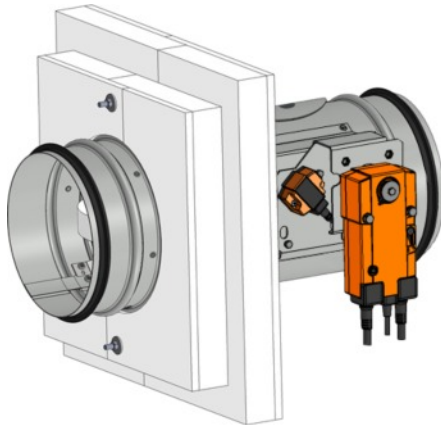

Installation frame R7

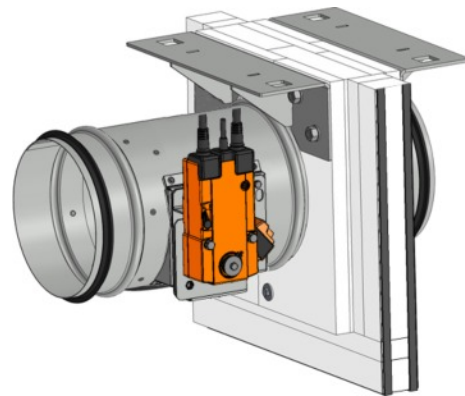

Installation frame can be delivered mounted on the damper body or separately.

Installation frame R1, R2

Installation frames R1, R2 are suitable for:

- Solid wall construction
- Gypsum wall construction
- Solid ceiling construction

On the inside and outside is installation frame equipped by intumescent sealing. It enlarges its capacity and air proofs the gap between damper body and installation frame and between installation frame and wall construction.

Installation frame R1 - solid wall/gypsum wall th. 100mm or solid ceiling th. 150 mm

Installation frame R2 - solid wall/gypsum wall th. 150mm or solid ceiling th. 150 mm

Installation:

- Gypsum wall construction has to be installed according manufacture requirements.

Material:

- Installation frame: cement lime plates
- Fasteners: galvanized plate

Installation opening:

- $a \times b = (D + 143^{+3}mm) \times (D + 143^{+3}mm)$

Fig. 89 Installation frame R1, R2

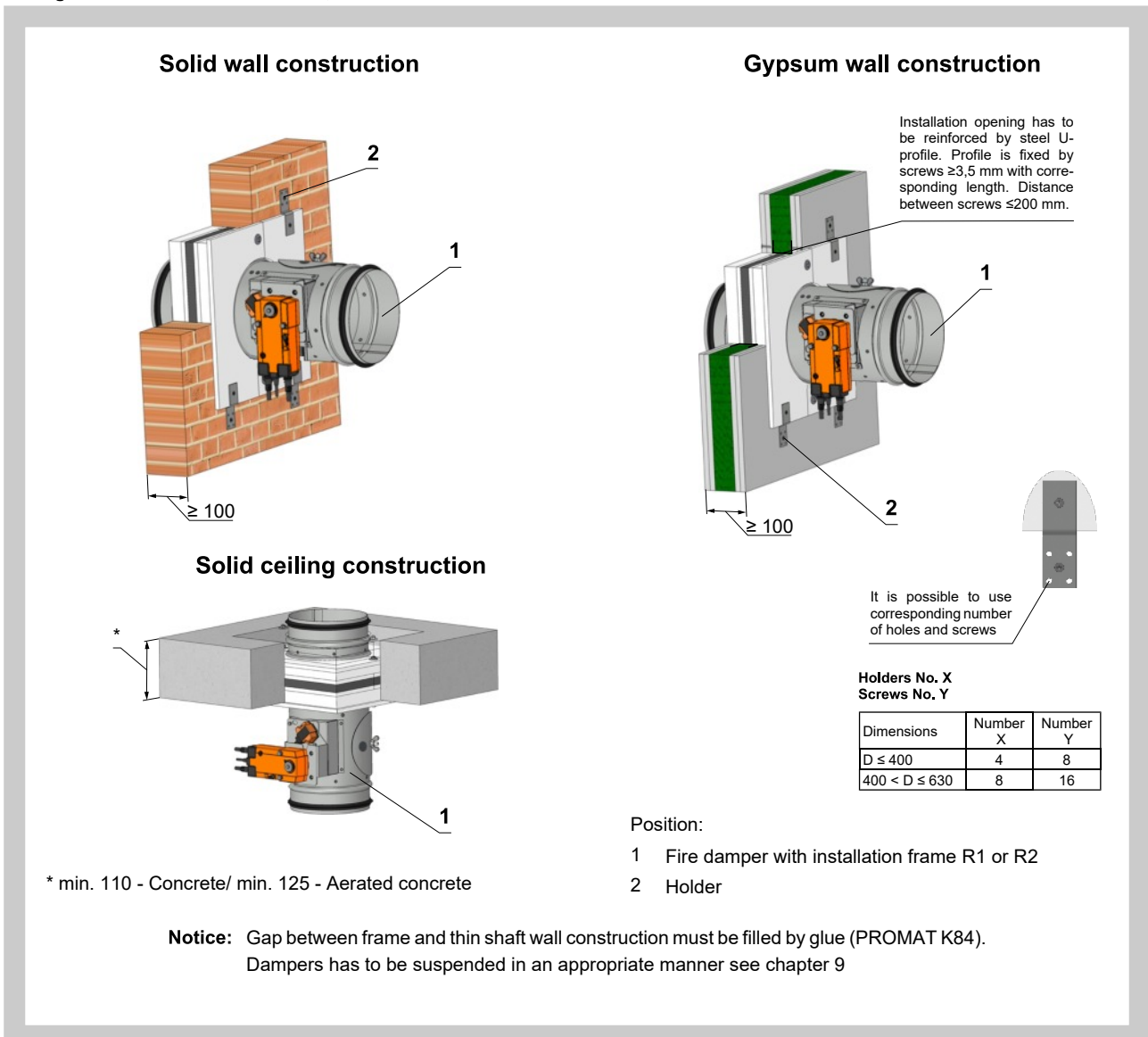

Installation frame R3, R4

Installation frame R3, R4 are suitable for:

- Solid wall construction
- Gypsum wall construction
- Solid ceiling construction

On the inside and outside is installation frame equipped by intumescent sealing. It enlarges its capacity and air proofs the gap between damper body and installation frame and between installation frame and wall construction.

Installation frame R3 - solid wall/gypsum wall th. 100mm or solid ceiling th. 150 mm
Installation frame R4 - solid wall/gypsum wall th. 150mm or solid ceiling th. 150 mm

Installation:

- Gypsum wall construction has to be installed according manufacture requirements.

Material:

- Installation frame: cement lime plates
- Fasteners: galvanized plate

Installation opening:

- $d = (D + 113^{+3}mm)$

Fig. 90 Installation frame R3, R4

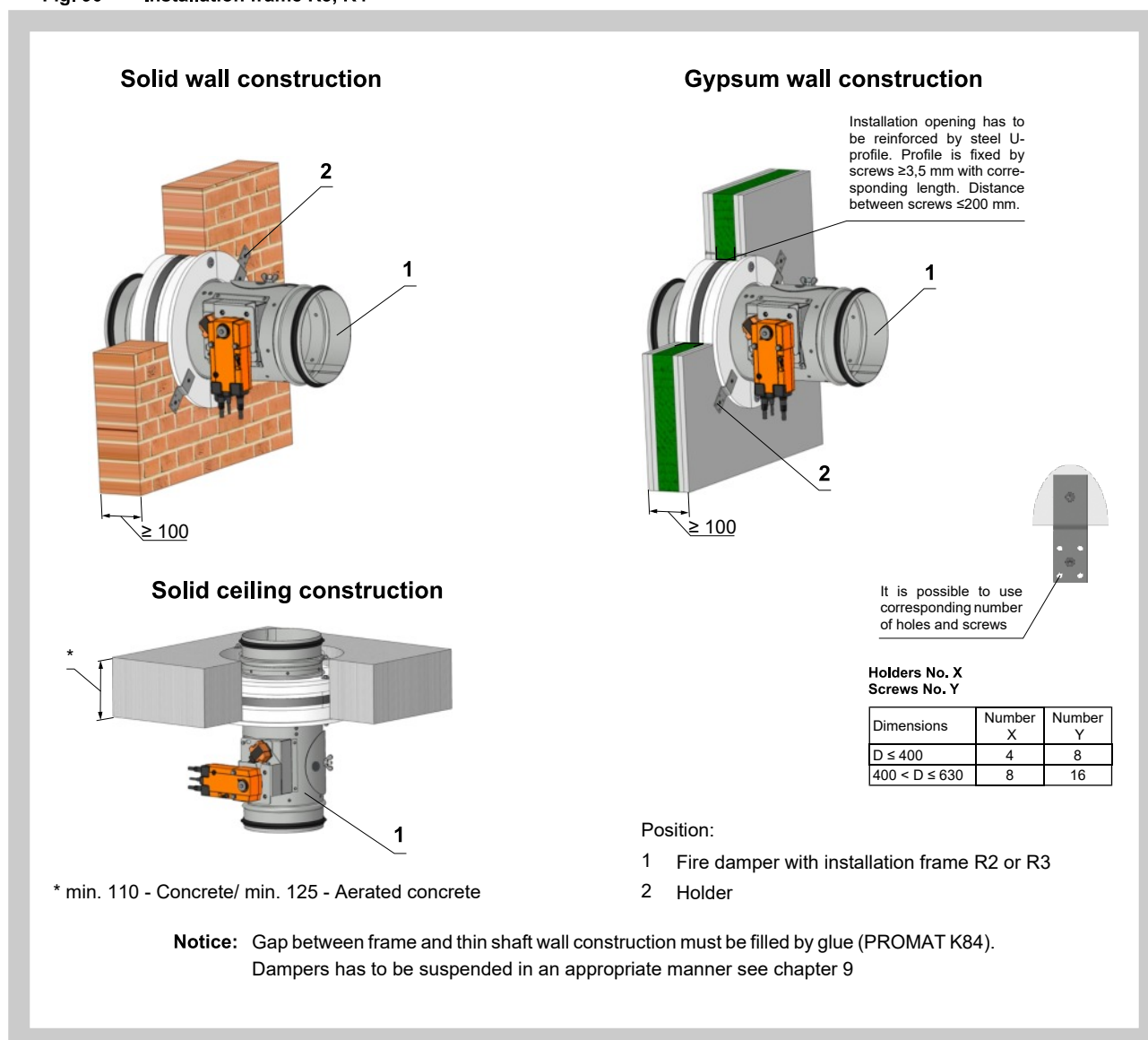

Installation frame R5 (DN 100 - 200)

Installation frame R5 is suitable for:

- SPIRO design only (without flanges)
- Installation on solid wall/ceiling construction
- Installation on gypsum wall construction
- Installation outside solid ceiling constructions with concrete

On the inside is installation frame equipped by intumescent sealing. It enlarges its capacity and air proofs the gap between installation frame and damper body.

Installation:

- Gypsum wall construction has to be installed according manufacture requirements.

Material:

- Installation frame: cement lime plates and galvanized plate
- Fasteners: galvanized plate

Installation opening:

- $d = (D + 10^{+3}mm)$
- $d = (D + 100^{+3}mm)$ installation with concrete

Fig. 91 Installation frame R5 (DN 100 - 200)

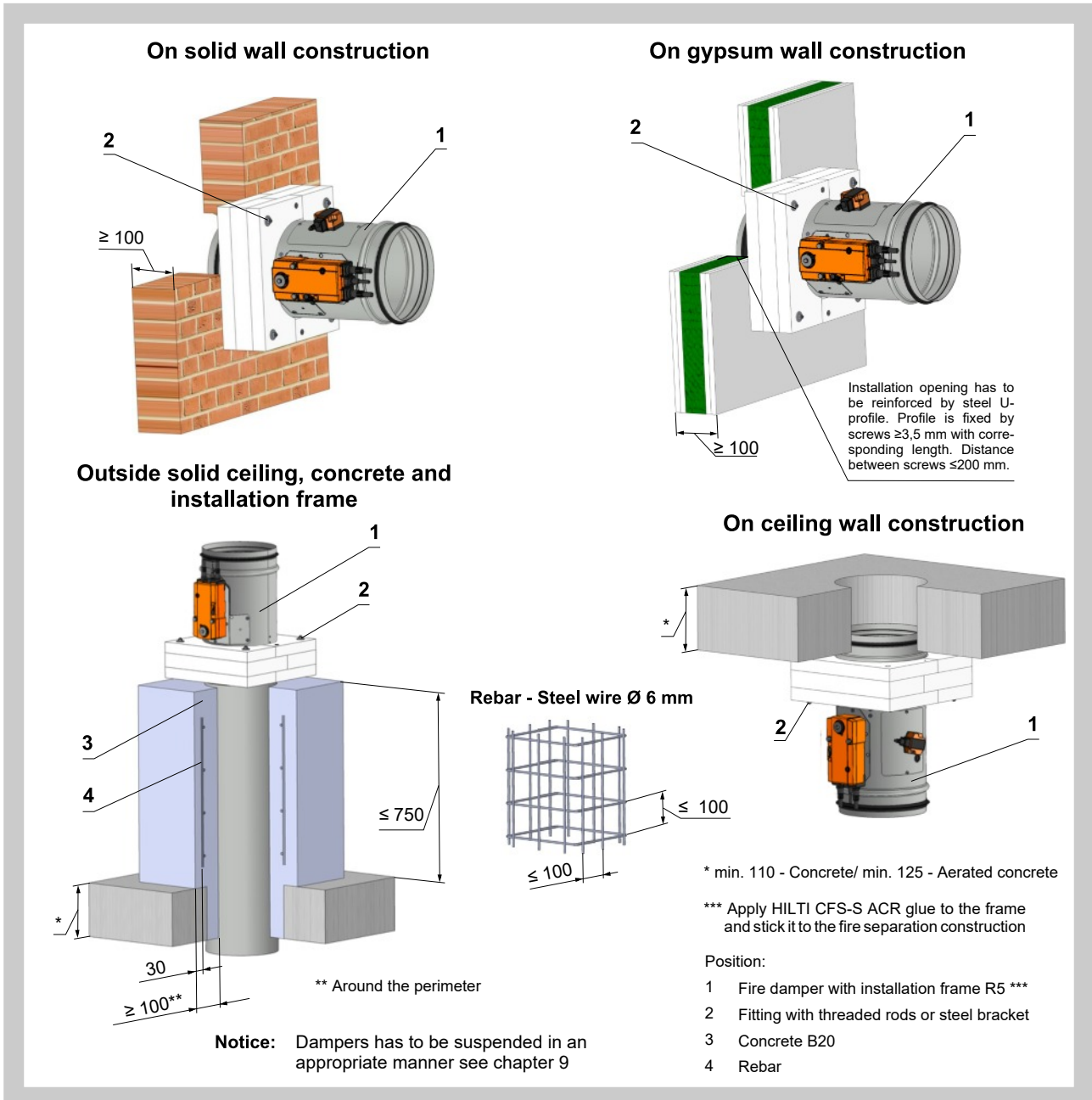

Installation frame R5 (DN 225 - 800)

Installation frame R5 is suitable for:

- SPIRO design only (without flanges)
- Installation on solid wall/ceiling construction
- Installation on gypsum wall construction
- Installation outside solid ceiling constructions with concrete

On the inside is installation frame equipped by intumescent sealing. It enlarges its capacity and air proofs the gap between installation frame and damper body.

Installation:

- Gypsum wall construction has to be installed according manufacture requirements.

Material:

- Installation frame: cement lime plates and galvanized plate
- Fasteners: galvanized plate

Installation opening:

- $d = (D + 10^{+3}mm)$
- $d = (D + 100^{+3}mm)$ installation with concrete

Fig. 92 Installation frame R5 (DN 225 - 800)

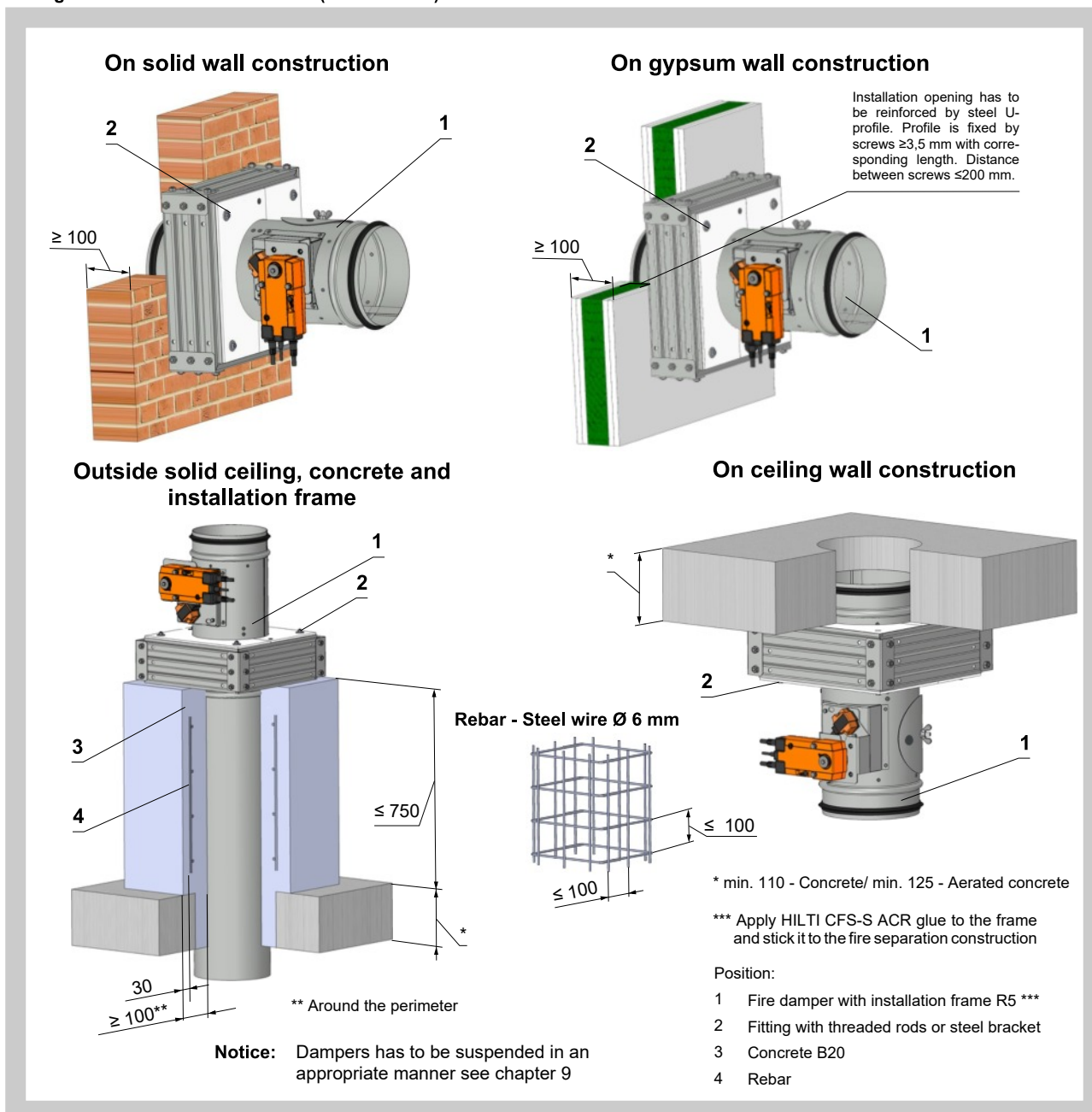

Installation frame R6

Installation frame R6 is suitable for:

- Installation outside solid wall/ceiling construction with cement lime plates

On the inside is installation frame equipped by intumescent sealing. It enlarges its capacity and air proofs the gap between installation frame and damper body.

Material:

- Installation frame: cement lime plates
- Fasteners: galvanized plate

Installation opening:

- $d = (D + 100)^{+3}mm$

Fig. 93 Installation frame R6

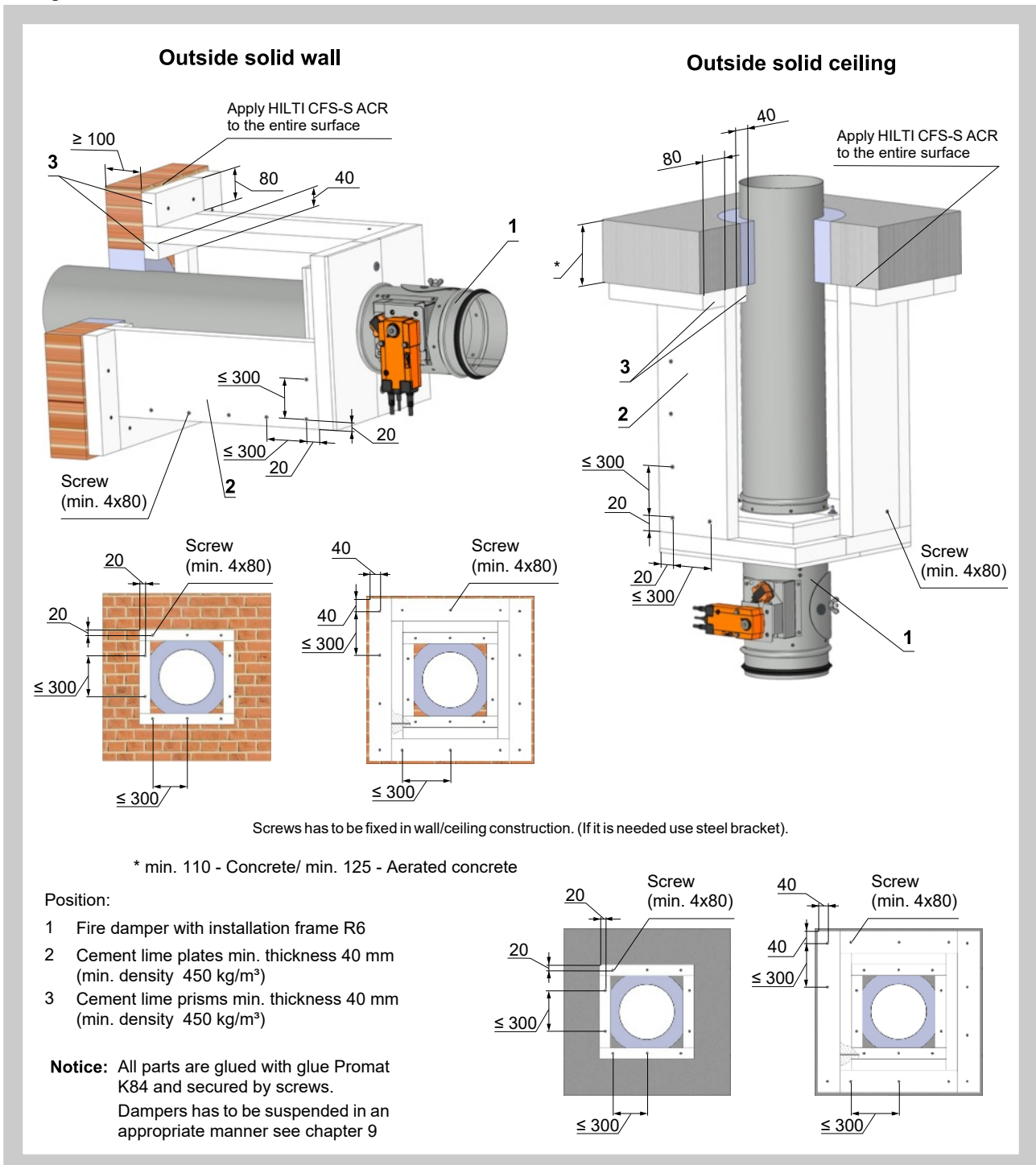

Installation frame R7

Installation frame R7 is suitable for gypsum wall construction with ceiling movement possibility. Distance of movement "x".

On the inside and outside is installation frame equipped by intumescent sealing. It enlarges its capacity and air proofs the gap between damper body and installation frame and between installation frame and wall construction.

Installation:

Damper position:

- Directly on the ceiling
- In distance from ceiling max. 80 mm

Material:

- Installation frame: cement lime plates
- Fasteners: galvanized plate

Notice:

- For ceiling movement ≥ 10 mm

Fig. 94 Installation frame R7

Gypsum wall construction with flexible ceiling (with possibility to move/to sag)

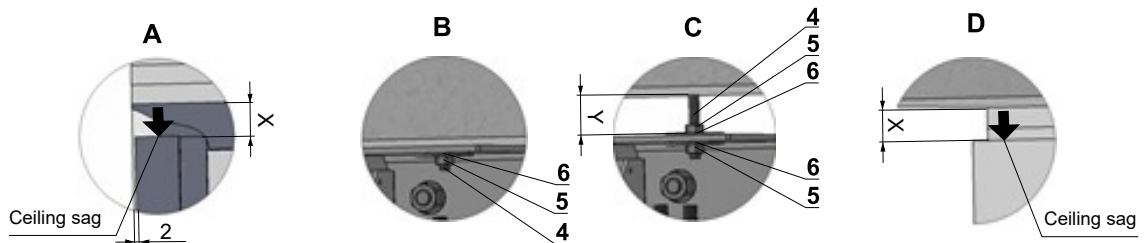

Directly on the ceiling

In distance "y" with filling

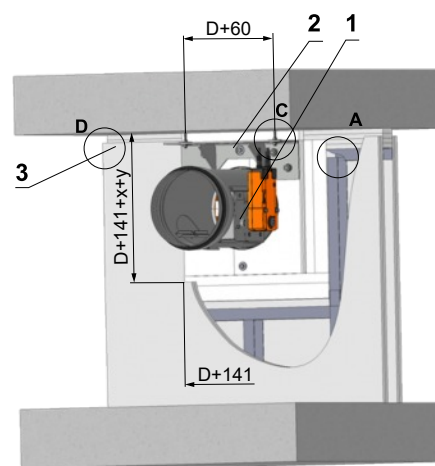
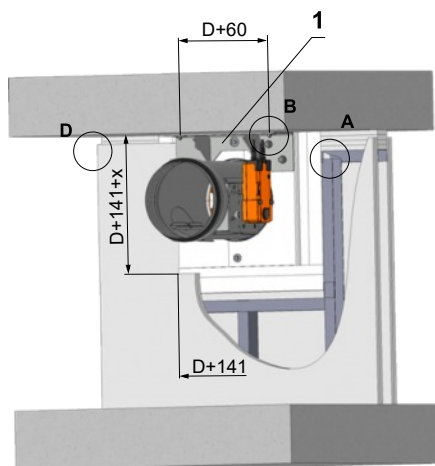

Position:

- 1 Fire damper with installation frame R7
- 2 Cement lime filling min. density 450 kg/m³
- 3 Ceiling movement: construction th. 100 mm
- 4 Threaded rod
- 5 Nut
- 6 Washer \varnothing 35 mm

X = Ceiling movement (max. 40 mm)
 Y = Distance of movement (max. 80 mm)

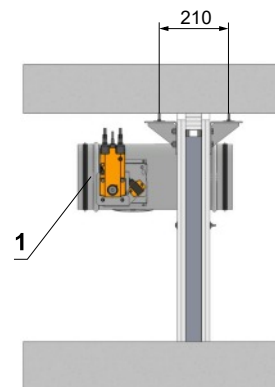

Notice: Fitting with threaded rods or steel bracket.

9. Suspension systems

9.1. Mounting to the ceiling wall

Fig. 95 Mounting to the ceiling wall

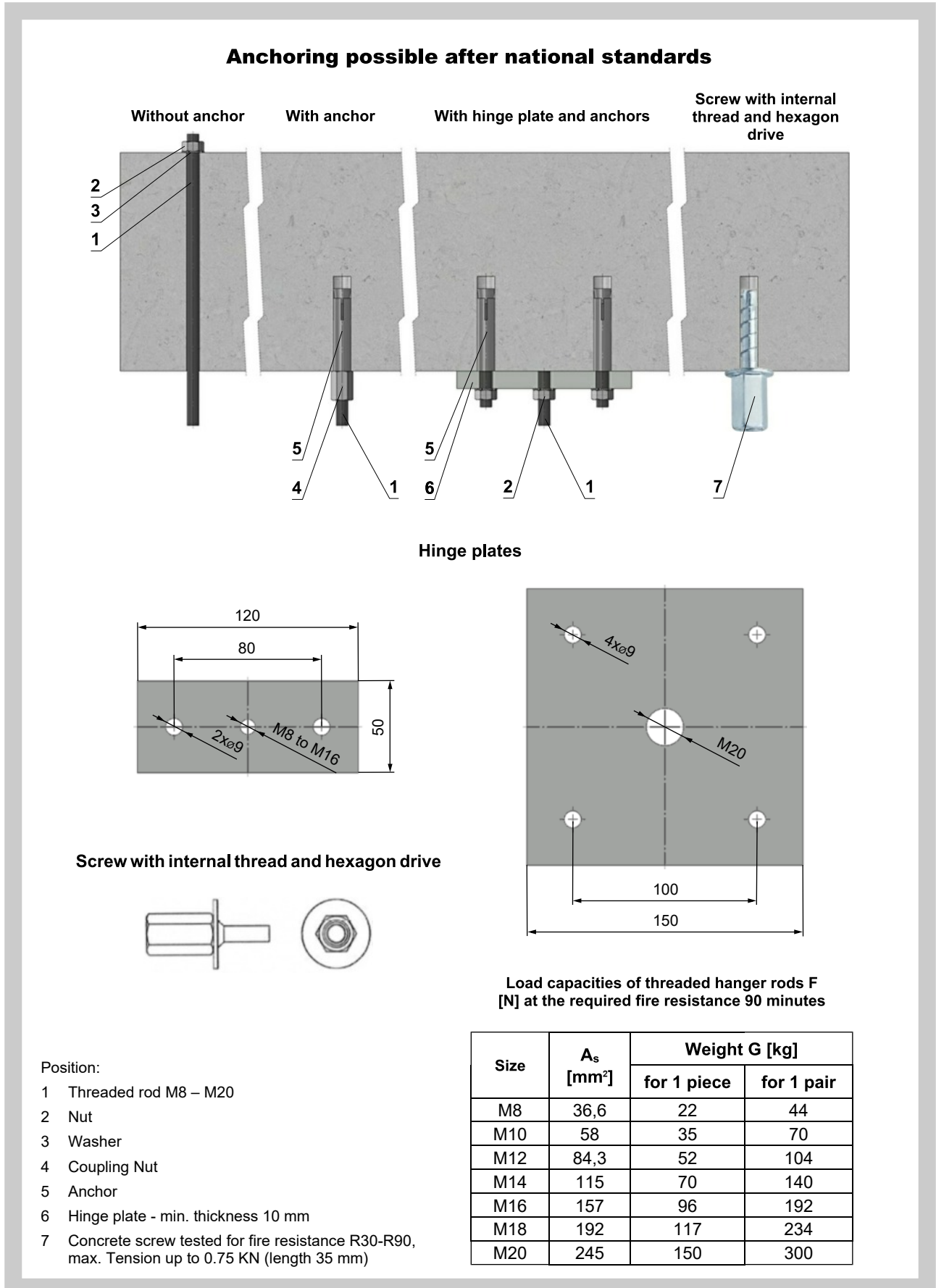

9.2. Fixing fire damper to the wall with stuffing box (stone wool + mastic)

Fig. 96 Fixing fire damper to the wall with stuffing box (stone wool + mastic)

In solid wall construction

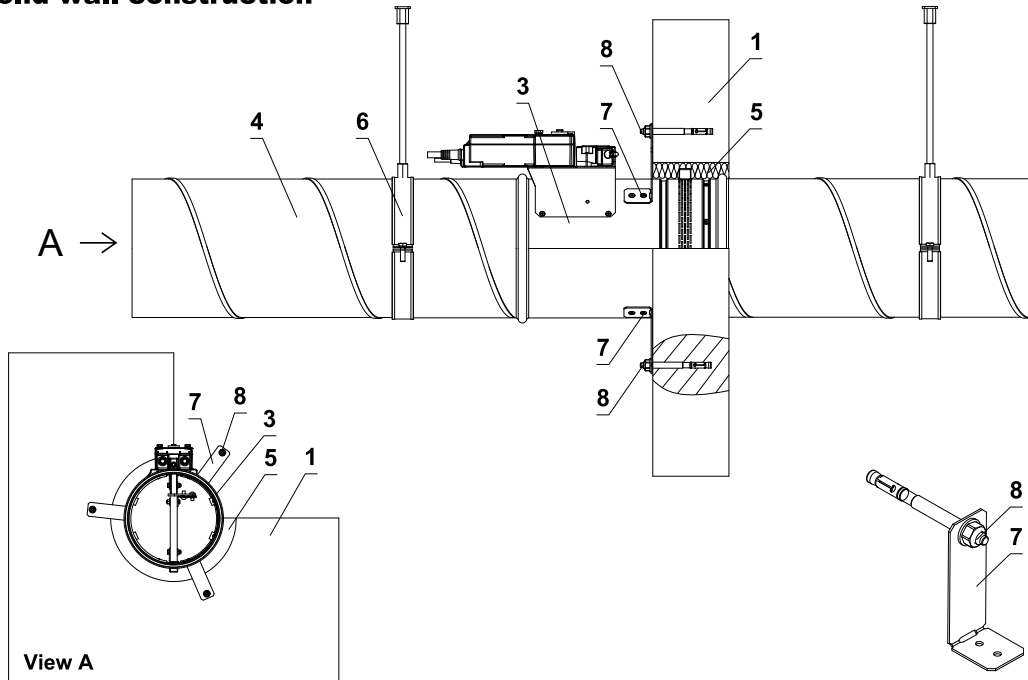

In gypsum wall construction

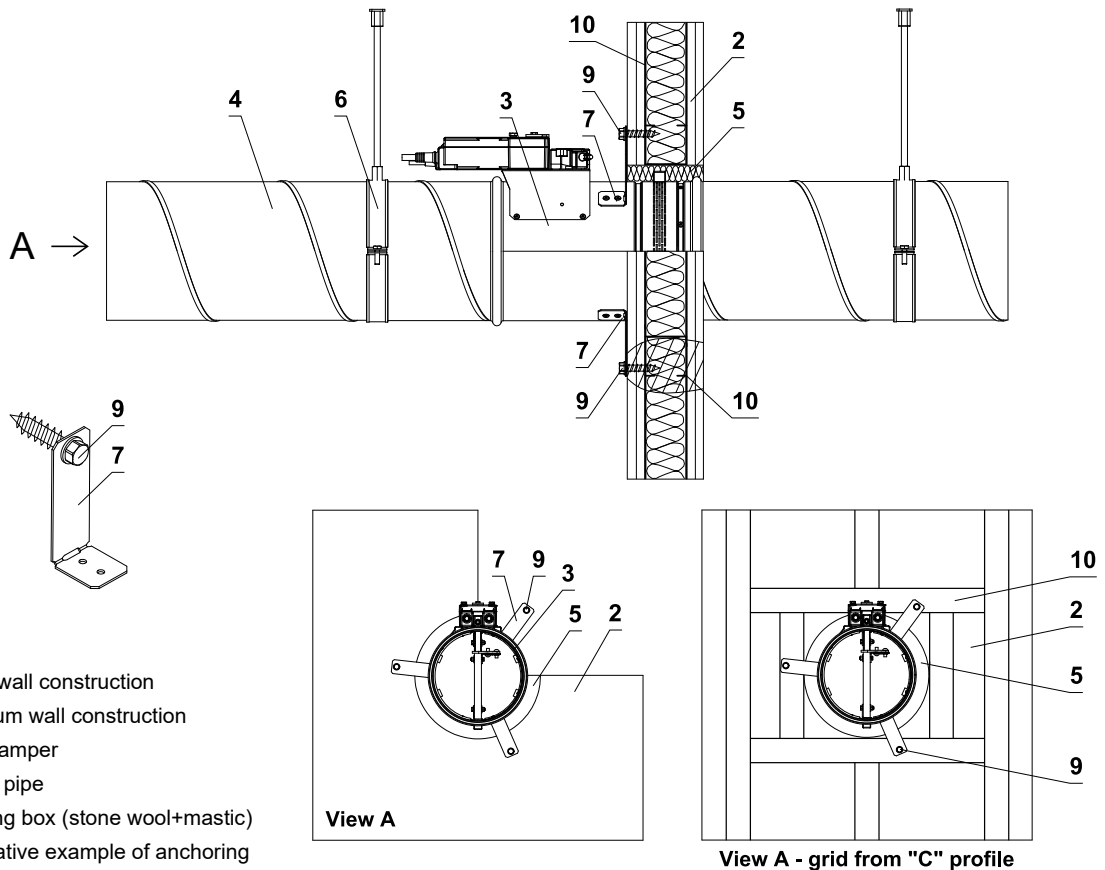

Position:

- 1 Solid wall construction
- 2 Gypsum wall construction
- 3 Fire damper
- 4 Spiral pipe
- 5 Stuffing box (stone wool+mastic)
- 6 Illustrative example of anchoring
- 7 Damper bracket
- 8 Nut M8 with anchor
- 9 Screw with hexagon head
- 10 Gypsum grid from "C" profile

Notice:

Assembly and mounting shown on the picture are illustrative and serve as a guide. The method of attachment must follow the minimum requirements for attachment and connection of ductwork in accordance with national regulations. Also, the elements can be suspended from the top, or supported from bottom, or fastened from the side.

9.3. Fixing fire damper to the ceiling with stuffing box (stone wool + mastic)

Fig. 97 Fixing fire damper to the ceiling with stuffing box (stone wool + mastic)

In solid ceiling construction

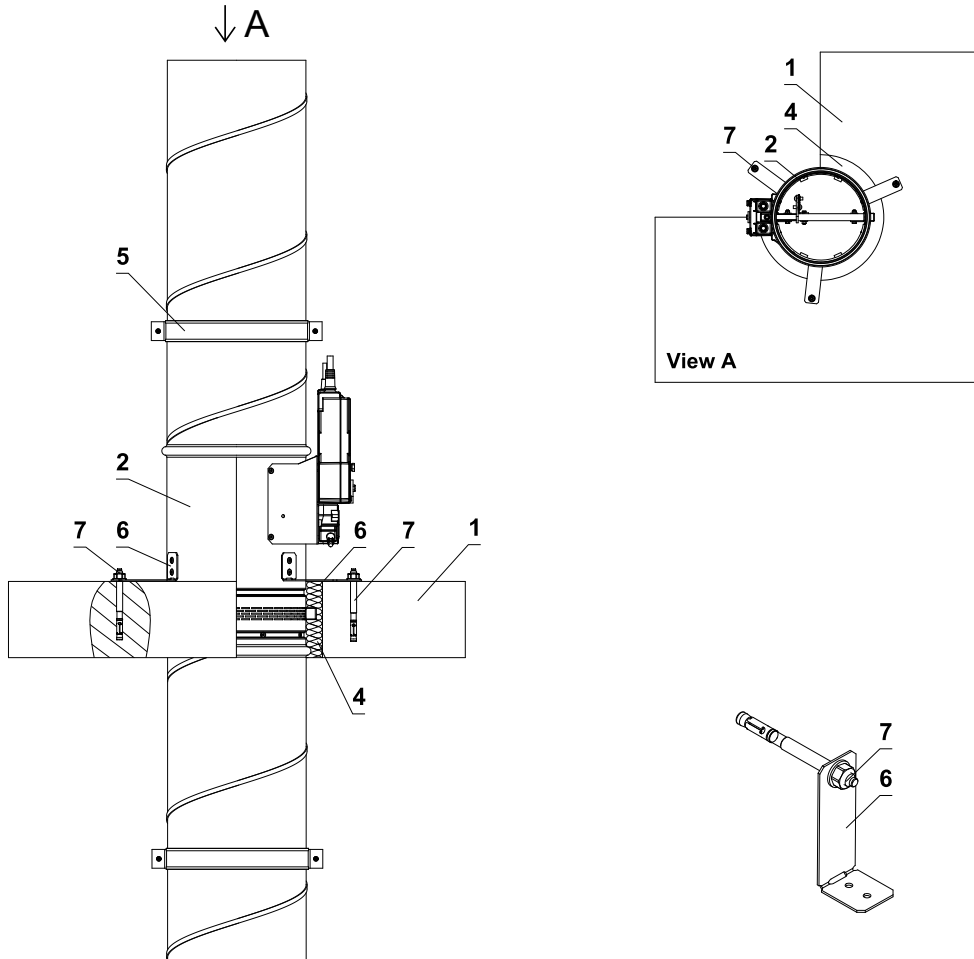

Position:

- 1 Solid ceiling construction
- 2 Fire damper
- 3 Spiral pipe
- 4 Stuffing box (stone wool+mastic)
- 5 Illustrative example of anchoring
- 6 Damper bracket
- 7 Nut M8 with anchor

Notice:

Assembly and mounting shown on the picture are illustrative and serve as a guide. The method of attachment must follow the minimum requirements for attachment and connection of ductwork in accordance with national regulations. Also, the elements can be suspended from the top, or supported from bottom, or fastened from the side.

9.4. Fixing fire damper and pipe, outside wall with insulation, stuffing box (stone wool + mastic)

Fig. 98 Fixing fire damper and pipe, outside wall with insulation, stuffing box (stone wool + mastic)

Outside solid wall construction

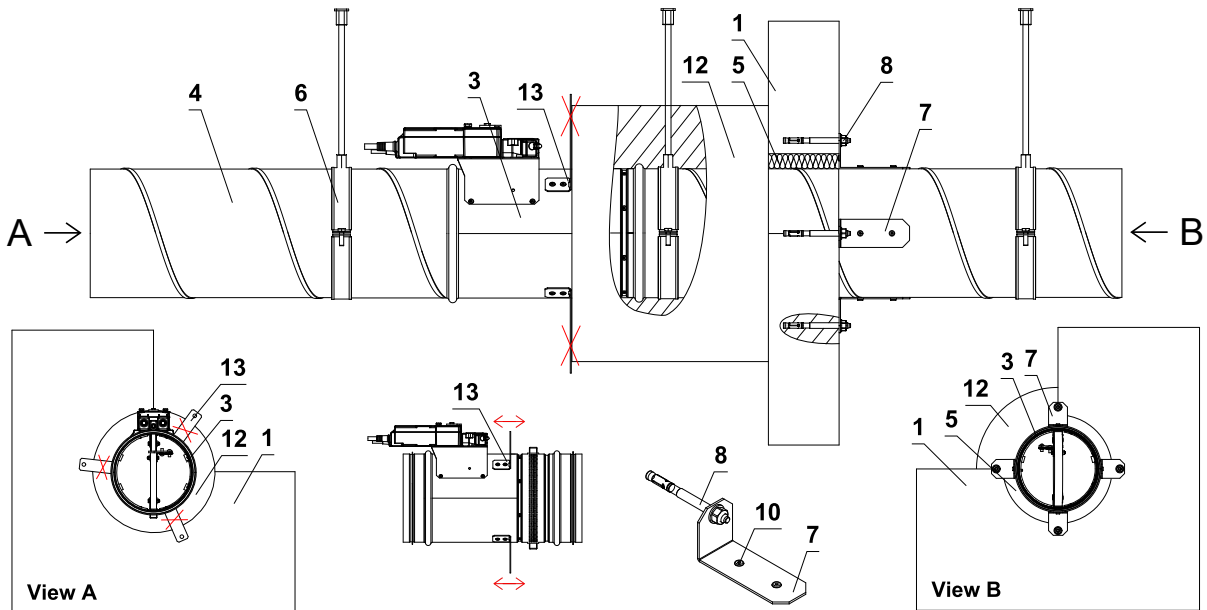

Outside gypsum wall construction

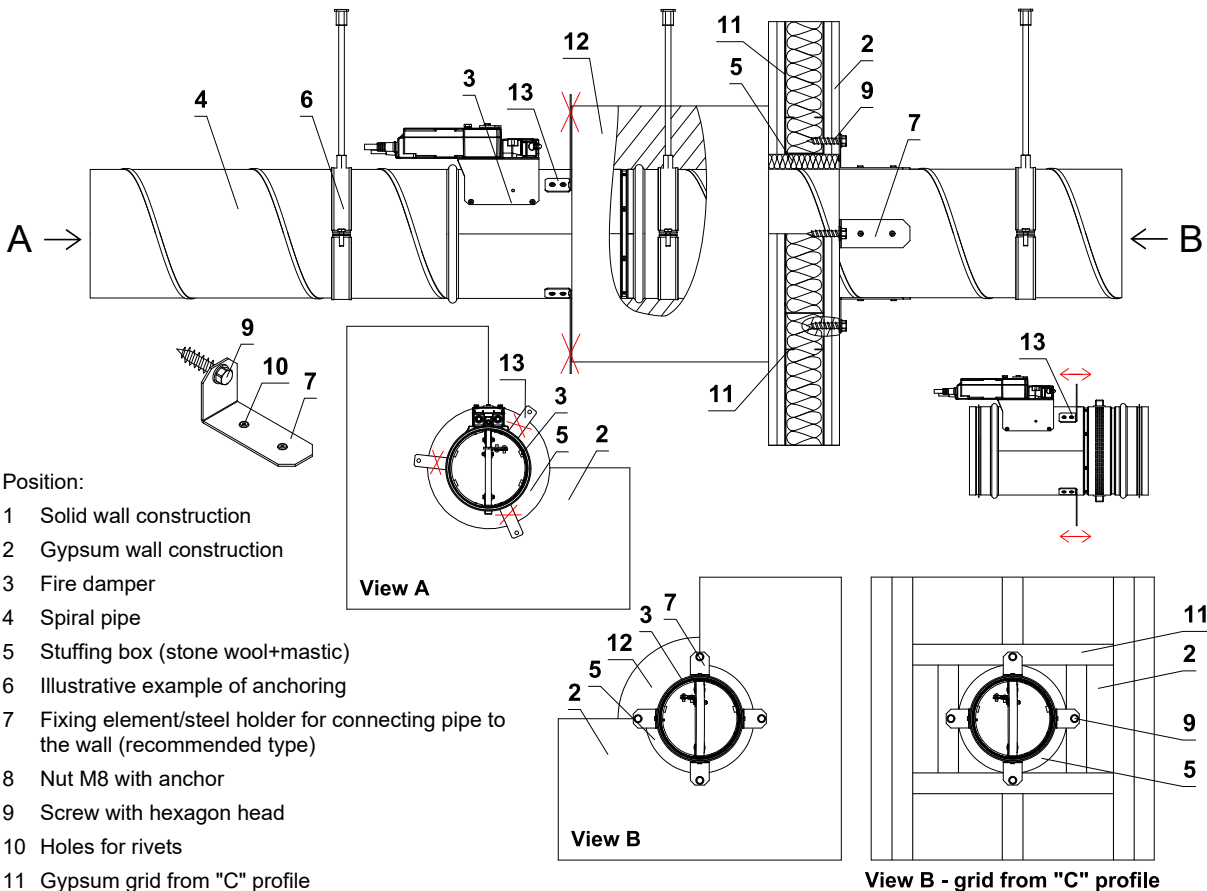

Position:

- 1 Solid wall construction
- 2 Gypsum wall construction
- 3 Fire damper
- 4 Spiral pipe
- 5 Stuffing box (stone wool+mastic)
- 6 Illustrative example of anchoring
- 7 Fixing element/steel holder for connecting pipe to the wall (recommended type)
- 8 Nut M8 with anchor
- 9 Screw with hexagon head
- 10 Holes for rivets
- 11 Gypsum grid from "C" profile
- 12 Pipe insulation
- 13 The brackets determine the min. length of insulation to keep the blade under insulated part. Turn the brackets by 90 degrees. In case of longer insulation than position of brackets, break off the brackets by tilting.

Notice:

Assembly and mounting shown on the picture are illustrative and serve as a guide. The method of attachment must follow the minimum requirements for attachment and connection of ductwork in accordance with national regulations. Also, the elements can be suspended from the top, or supported from bottom, or fastened from the side.

9.5. Fixing fire damper and pipe, outside ceiling with insulation, stuffing box (stone wool + mastic)

Fig. 99 Fixing fire damper and pipe, outside ceiling with insulation, stuffing box (stone wool + mastic)

Outside solid ceiling construction

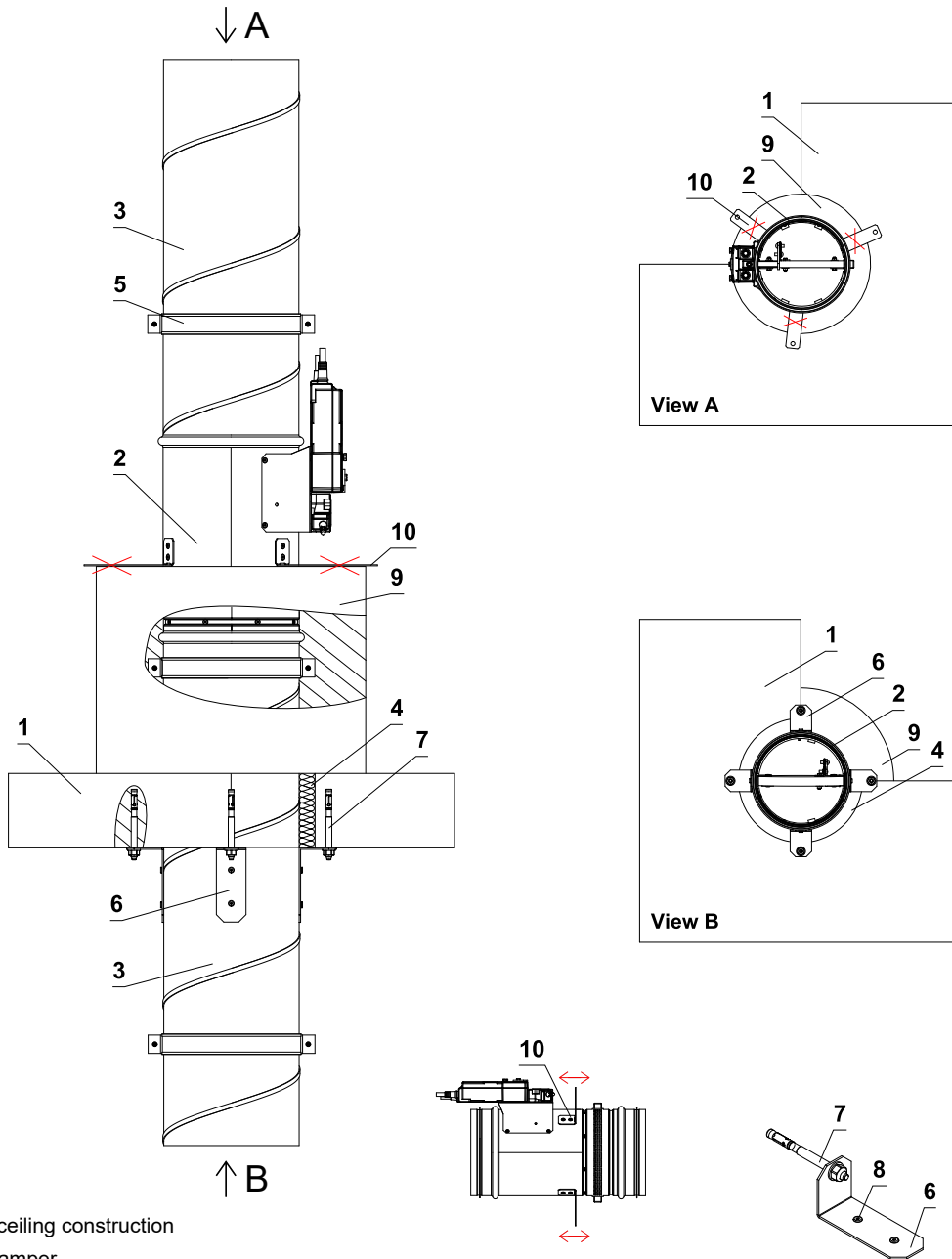

Position:

- 1 Solid ceiling construction
- 2 Fire damper
- 3 Spiral pipe
- 4 Stuffing box (stone wool+mastic)
- 5 Illustrative example of anchoring
- 6 Fixing element/steel holder for connecting pipe to the ceiling (recommended type)
- 7 Nut M8 with anchor
- 8 Holes for rivets
- 9 Pipe insulation
- 10 The brackets determine the min. length of insulation to keep the blade under insulated part. Turn the brackets by 90 degrees. In case of longer insulation than position of brackets, break off the brackets by tilting.

Notice:

Assembly and mounting shown on the picture are illustrative and serve as a guide. The method of attachment must follow the minimum requirements for attachment and connection of ductwork in accordance with national regulations. Also, the elements can be suspended from the top, or supported from bottom, or fastened from the side.

9.6. Horizontal installation

Damper assembly procedures must be done so as all load transfer from the fire separating constructions to the damper body is absolutely excluded. Back-to-back air-conditioning piping must be hung or supported so as all load transfer from the back-to-back piping to the damper is absolutely excluded.

On Fig. 100 is typical mounting situation as an example.

Threaded rods longer than 1,5 m require fire-resistant insulation.

Threaded rod fixing to the ceiling construction - see fig. 95

Fig. 100 Suspension - horizontal duct (soft padding - mineral wool + fire boards)

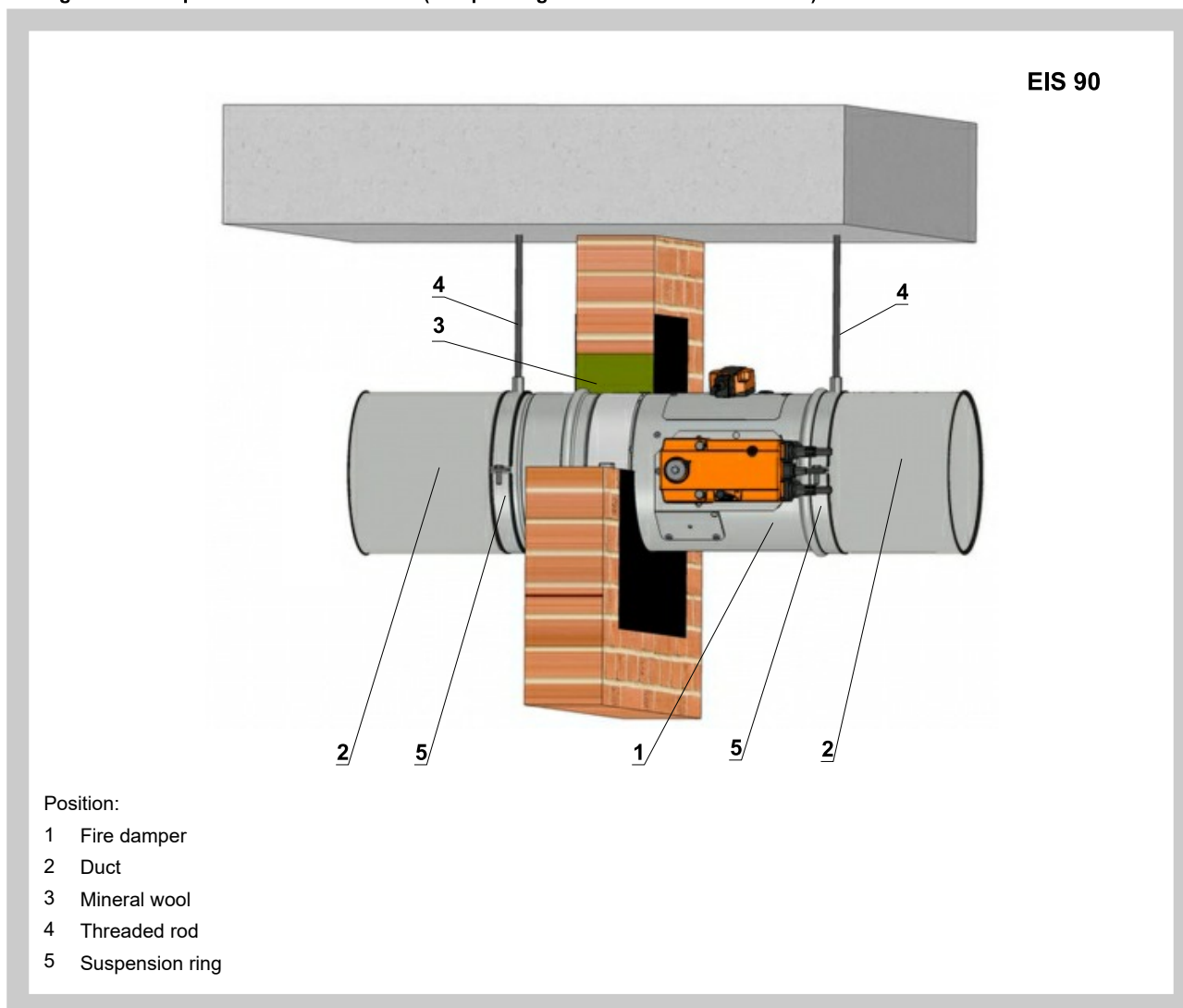

9.7. Vertical installation

The damper must not be suspended or anchored. The duct must be anchored after national rules, like in fig. 101 - as an example. It can be suspended by using threaded rods and a mounting profiles. Load the suspension system depend on weight of the fire damper.

Damper can be suspended from the ceiling construction or supported above the ceiling construction.

Damper assembly procedures must be done so as all load transfer from the fire separating constructions to the damper body is absolutely excluded. Back-to-back air-conditioning piping must be hung or supported so as all load transfer from the back-to-back piping to the damper is absolutely excluded.

Threaded rods longer than 1,5 m require fire-resistant insulation.

Threaded rod fixing to the ceiling construction - see fig. 95

Fig. 101 Suspension - vertical duct

Actuating mechanism is placed above the ceiling construction

EIS 90

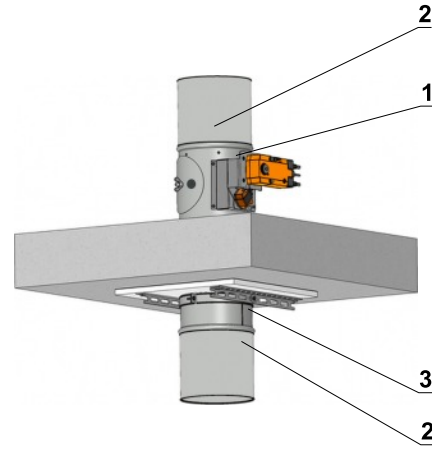
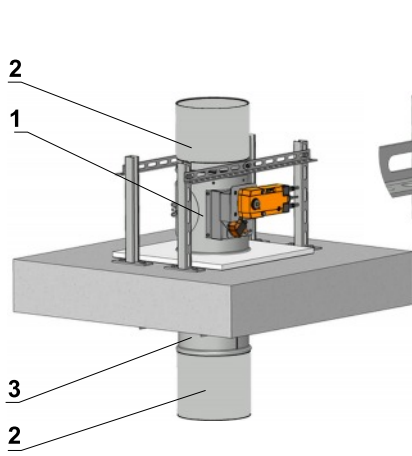

Actuating mechanism is placed under the ceiling construction

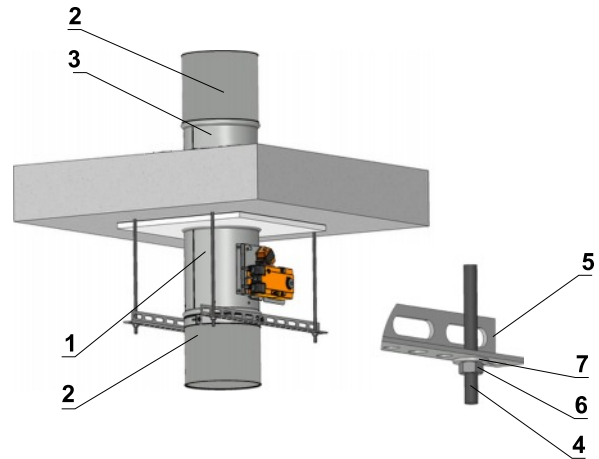
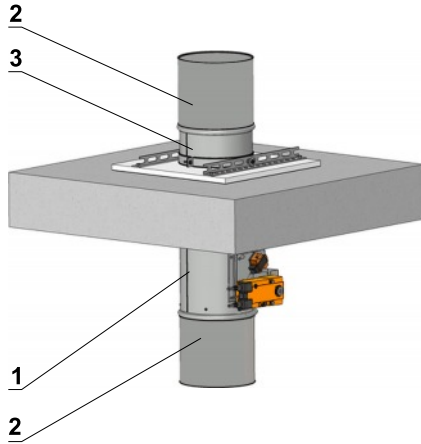

Notice: Damper must be firmly connected with extension piece by screws or rivets.

Suspension ring and mounting rail connected by bolt

Suspension ring and mounting rail connected by screw or rivet

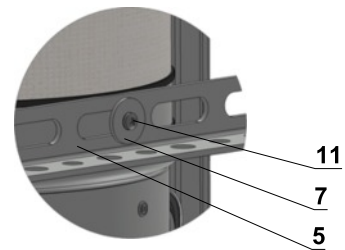
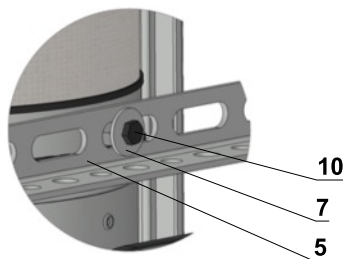

Position:

- 1 Fire damper
- 2 Damping pad
- 3 Extension piece
- 4 Threaded rod
- 5 Mounting rail
- 6 Nut
- 7 Washer
- 8 Screw connection
- 9 Mounting profile
- 10 Bolt
- 11 Screw or rivet

Examples of using materials: HILTI, SIKLA, MÜPRO etc.

9.8. Rectangular fire damper suspension remote from the wall - horizontal installation

Fire dampers installed remote from the wall must be suspended.
The duct must be suspended on both sides of damper after national rules.

Duct between fire damper and fire separating construction must be suspended by using threaded rods and mounting profiles, or another anchoring system according national standards. Load the suspension system depend on weight of the fire damper and duct system.

Max. length between two suspension systems is 1500 mm.

Damper assembly procedures must be done so as all load transfer from the fire separating constructions to the damper body is absolutely excluded. Back-to-back air-conditioning piping must be hung or supported so as all load transfer from the back-to-back piping to the damper is absolutely excluded.

Threaded rods longer than 1,5 m require fire-resistant insulation.

If the threaded rod is located inside the duct insulation, distance between threaded rod and duct is max 30 mm. If the treaded rod is located outside the duct isolation, distance between threaded rod and isolation is max. 40 mm. Thickness of the insulation under mounting profile must be min. 30 mm.

Threaded rod fixing to the ceiling construction - see fig. 95

The insulation boards are fastened to the duct.

For more information see documentation of insulation manufacturer.

Fig. 102 Suspension remote from the wall - horizontal installation

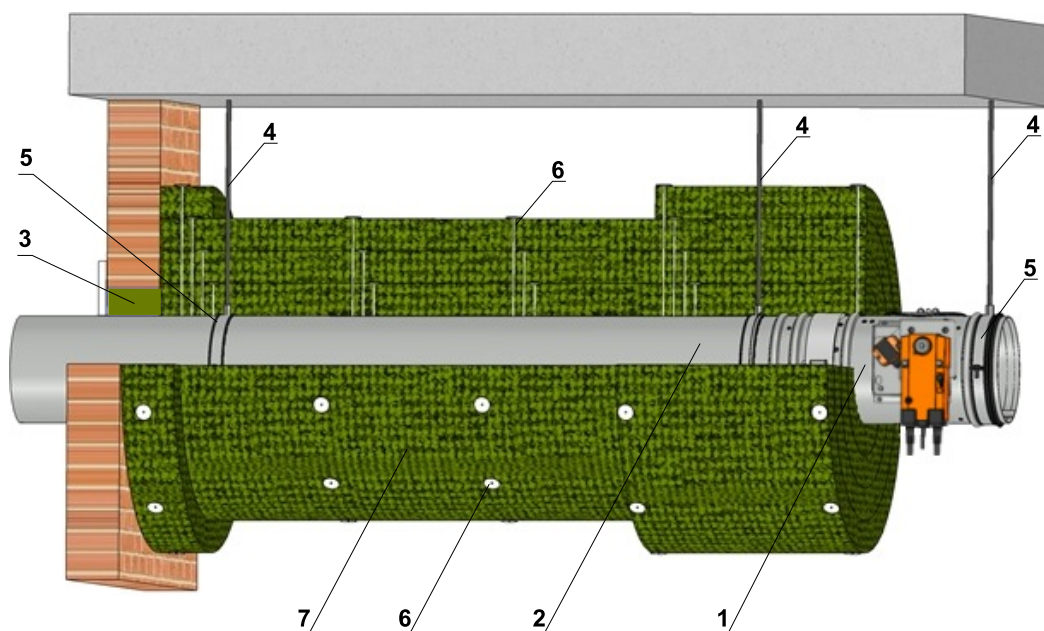

Position:

- 1 Fire damper
- 2 Duct
- 3 Soft padding (stone wool + fire board)
- 4 Threaded rod
- 5 Suspension ring
- 6 Weld pin
- 7 Insulation*

* Fixing the insulation to duct acc. to fire insulation supplier's instructions.

III. TECHNICAL DATA

10. Pressure loss

10.1. Pressure loss calculation

$$\Delta p = \xi \cdot \rho \cdot \frac{w^2}{2}$$

Δp	[Pa]	pressure loss
w	[m.s ⁻¹]	air flow speed in nominal damper section
ρ	[kg.m ³]	air density
ξ	[-]	coefficient of local pressure loss for the nominal damper section (see Tab. 11.1.1.)

10.2. Determination of pressure loss by using diagram $\rho = 1,2 \text{ kg.m}^3$

Diagram 10.2.1. Pressure losses for air density $\rho = 1,2 \text{ kg.m}^3$

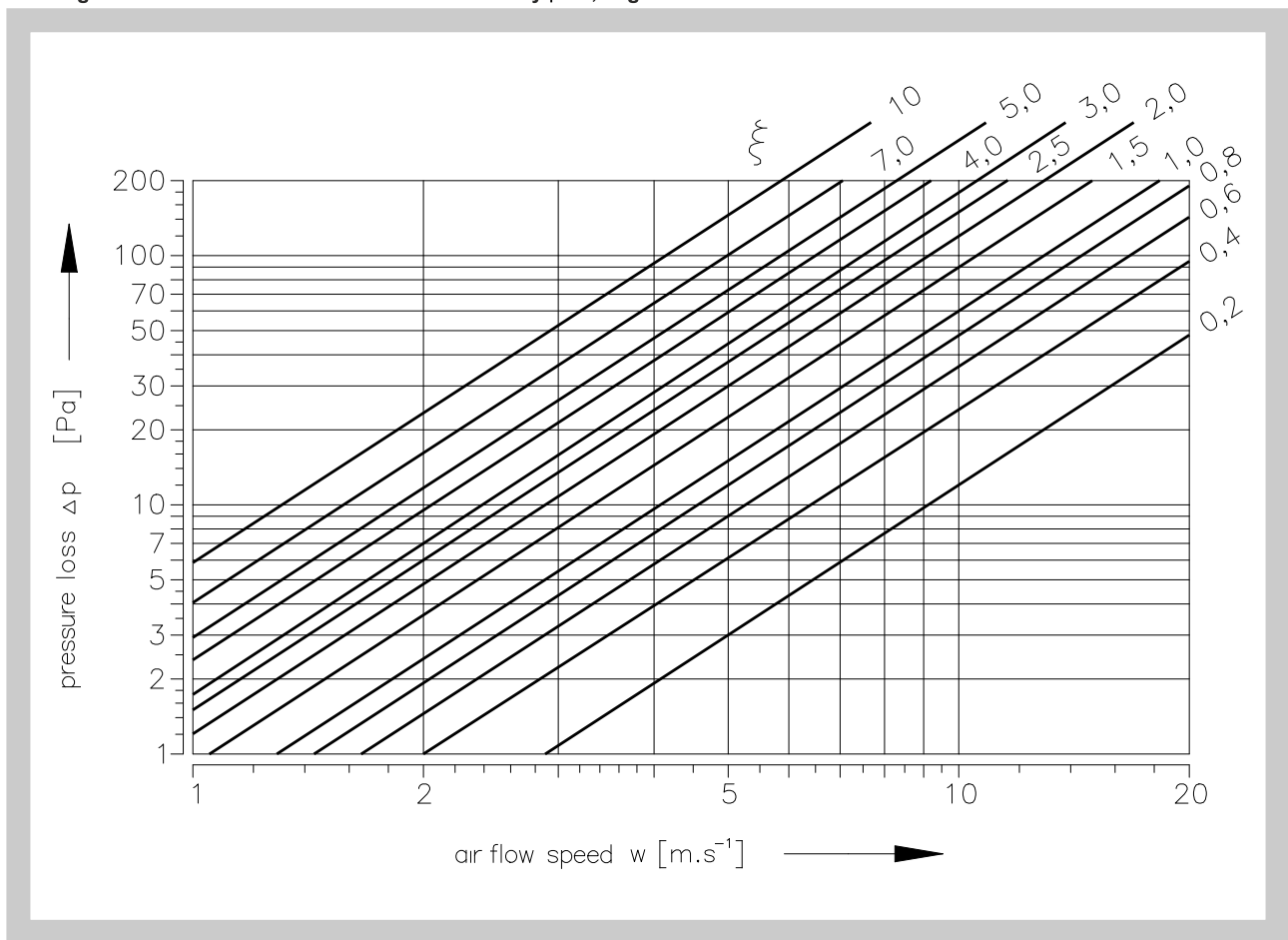

11. Coefficient of local pressure loss

11.1. Coefficient of local pressure loss ξ (-)

Tab. 11.1.1. Coefficient of local pressure loss

D	100	125	140	150	160	180	200	225	250	280
ξ	2,736	2,099	1,781	1,527	1,272	0,929	0,636	0,892	0,747	0,627
D	315	355	400	450	500	560	630	710	800	
ξ	0,531	0,455	0,393	0,344	0,307	0,273	0,243	0,111	0,099	

12. Noise data

12.1. Level of acoustic output corrected with filter A.

$$L_{WA} = L_{W1} + 10 \log(S) + K_A$$

L_{WA} [dB(A)] level of acoustic output corrected with filter A.

L_{W1} [dB] level of acoustic output L_{W1} related to the 1 m² section (see Tab. 12.3.1.)

S [m²] duct cross section

K_A [dB] correction to the weight filter A (see Tab. 12.3.2.)

12.2. Level of acoustic output in octave ranges.

$$L_{Woct} = L_{W1} + 10 \log(S) + L_{rel}$$

L_{Woct} [dB] spectrum of acoustic output in octave range

L_{W1} [dB] level of acoustic output L_{W1} related to the 1 m² section (see Tab. 12.3.1.)

S [m²] duct cross section

L_{rel} [dB] relative level expressing the shape of the spectrum (see Tab. 12.3.3.)

12.3. Table of acoustics values

Tab. 12.3.1. Level of acoustic output L_{w1} [dB] related to the 1 m² section

w [m.s ⁻¹]	ξ [-]											
	0,1	0,2	0,3	0,4	0,6	0,8	1	1,5	2	2,5	3	3,5
2	9	11,5	14,7	16,9	20,1	22,3	24,1	27,2	29,4	31,2	32,6	33,8
3	16,7	22,1	25,3	27,5	30,7	32,9	34,6	37,8	40	41,7	43,2	44,4
4	24,2	29,6	32,8	35	38,1	40,4	42,1	45,3	47,5	49,2	50,7	51,9
5	30,0	35,4	38,6	40,8	44	46,2	47,9	51,1	53,3	55,1	56,5	57,7
6	34,8	40,2	43,3	45,6	48,7	51	52,7	55,8	58,1	59,8	61,2	62,4
7	38,8	44,2	47,3	49,6	52,7	55	56,7	59,9	62,1	63,8	65,2	66,4
8	42,3	47,7	50,8	53,1	56,2	58,4	60,2	63,3	65,6	67,3	68,7	69,9
9	45,4	50,7	53,9	56,1	59,3	61,5	63,3	66,4	68,6	70,4	71,8	73
10	48,1	53,5	56,6	58,9	62	64,3	66	69,1	71,4	73,1	74,5	75,7
11	50,6	56	59,1	61,4	64,5	66,7	68,5	71,6	73,9	75,6	77	78,2
12	52,8	58,2	61,4	63,6	66,8	69	70,7	73,9	76,1	77,9	79,3	80,5

Tab. 12.3.2. Correction to the weight filter A

w [m.s ⁻¹]	2	3	4	5	6	7	8	9	10	11	12
K_A [dB]	-15,0	-11,8	-9,8	-8,4	-7,3	-6,4	-5,7	-5,0	-4,5	-4,0	-3,6

Tab. 12.3.3. Relative level expressing the shape of the spectrum L_{rel}

w [m.s ⁻¹]	f [Hz]							
	63	125	250	500	1000	2000	4000	8000
2	-4,5	-6,9	-10,9	-16,7	-24,1	-33,2	-43,9	-56,4
3	-3,9	-5,3	-8,4	-13,1	-19,5	-27,6	-37,4	-48,9
4	-3,9	-4,5	-6,9	-10,9	-16,7	-24,1	-33,2	-43,9
5	-4,0	-4,1	-5,9	-9,4	-14,6	-21,5	-30	-40,3
6	-4,2	-3,9	-5,3	-8,4	-13,1	-19,5	-27,6	-37,4
7	-4,5	-3,9	-4,9	-7,5	-11,9	-17,9	-25,7	-35,1
8	-4,9	-3,9	-4,5	-6,9	-10,9	-16,7	-24,1	-33,2
9	-5,2	-3,9	-4,3	-6,4	-10,1	-15,6	-22,7	-31,5
10	-5,5	-4	-4,1	-5,9	-9,4	-14,6	-21,5	-30
11	-5,9	-4,1	-4	-5,6	-8,9	-13,8	-20,4	-28,8
12	-6,2	-4,3	-3,9	-5,3	-8,4	-13,1	-19,5	-27,6

IV. MATERIAL, FINISHING

13. Material

- 13.1.** Damper bodies are supplied in the design made of galvanized plate without any other surface finishing.

Damper blades are made of fire resistant asbestos free boards made of mineral fibres.

Control devices of dampers has cover from mechanically resistant and standing plastic and rest of the parts is galvanised without further surface treatment.

Springs are galvanized.

Thermal protective fuses are made of sheet brass, thickness = 0.5 mm.

Fasteners is galvanized. Fasteners is galvanized.

- 13.2.** According to the customer's requirements, damper can be made of stainless material.

Specifications for stainless-steel models – classification of stainless steel:

- Class A2 – Food-grade stainless steel (AISI 304 – EN 17240)
- Class A4 – Chemistry-grade stainless steel (AISI 316, 316L – EN 17346, 17349)

The respective stainless steel is the material for all components present or accessing the damper interior; components outside the damper body are typically from galvanised sheet metal (fasteners for mounting the servo drive or mechanics, mechanics components except Item 4), frame components.

The following components, including the fasteners, are made from stainless steel at all times:

- 1) Damper body and all components permanently attached
- 2) Leaf holders, including pins, metal parts of leaf
- 3) Control components inside the damper (leaf angle selector, pin with lever)
- 4) Mechanical components entering the interior of damper body (lower sheet of mechanics, lock holder "1", lock lever "2", lock spring, 8 dia. stopper pin, mechanics pin)
- 5) Inspection hole cover including the clip and fasteners (if they are parts of the cover)
- 6) Bearing for torque transfer from the lever with pin on the angle selector at the leaf (made from AISI 440C)

The leaf of the damper is made of one homogeneous material, Promatect-H or Promatect MST, thickness according to damper size or is composite from two Promatect-H sheets, thickness 20 mm, connected with galvanised nailed "U" connectors which are sealed with Promat K84 from the outside.

Plastic, rubber and silicon components, sealants, foaming bands, glass-ceramic seals, housings, brass bearings of the leaf, servo drives, and end switches are identical for all material variants of the dampers.

The thermal fuse is identical for all material variants of the dampers. At customer's wish, the thermal fuse can be made of stainless metal sheet, mat. A4.

The temperature-dependent initiator of the servo drive (sensor) is modified for stainless-steel variants of the dampers; the standard galvanised screws are replaced with stainless-steel M4 screws of corresponding class the counterpart has stainless-steel riveting M4 nuts.

Some fasteners and components are available in one class of stainless steel; the type will be used in all stainless-steel variants.

The leaf in the variants for chemical environments (Class A4) is always treated with a coating of chemically resistant Promat SR.

Any other requirements for the design shall be considered atypical and shall be addressed on an individual basis.

V. INSPECTION, TESTING

14. Inspection

- 14.1.** Sizes are checked by common measuring instruments according to the standard of non-tolerated sizes, used in air conditioning industry.

Interoperational checks of components and main sizes are carried out according to drawing documentation.

15. Testing

- 15.1.** After workshop installation, a 100% check of function of closing mechanism and electric components is carried out.

VI. TRANSPORTATION AND STORAGE

16. Logistic terms

- 16.1.** The dampers are delivered as bulk cargo. Any other packing methods must be agreed with the manufacturer in advance. The potential packages will be considered non-returnable and their price will not be included in the product price.

The dampers are transported by box freight vehicles; no sharp shocks must occur and the ambient temperature must not exceed +40°C. For handling during transport, the dampers must be protected against mechanical damages and weather impact. If the customer wishes it, the dampers can be transported on pallets. During transport, the damper blade must be in the "CLOSED" position.

Unless another method of reception is specified in the purchase order, the handover of the dampers to the forwarder shall be understood as reception.

- 16.2.** The dampers must be stored in covered buildings, in an environment without aggressive vapours, gases and dust. A temperature in a range of -5°C and +40°C and a relative humidity of max. 80% must be maintained in the buildings.
For handling during storage, the dampers must be protected against mechanical damage.

- 16.3.** The delivery includes the complete damper and the delivery note.

17. Warranty

- 17.1.** The manufacturer provides a warranty of 24 months from the date of dispatch for the dampers.

The warranty for fire dampers FDMR, provided by the manufacturer, shall become completely null and void if the starting, closing and control devices are unprofessionally handled by untrained workers or if electric components, i.e. limit switches, actuating mechanisms, communication and supply devices and thermoelectric starting mechanisms are dismantled (see Art. 18.1 of the technical conditions). The warranty shall also become null and void if the dampers are used for other purposes, devices and working conditions than those allowed by these technical conditions or if the dampers are mechanically damaged during handling.

- 17.2.** If the dampers are damaged by transport, a record must be written down with the forwarder at reception for later complaint.

VII. ASSEMBLY, ATTENDANCE, MAINTENANCE AND REVISIONS

18. Assembly

- 18.1. The assembly of the dampers must be carried out while observing all applicable safety standards and regulations.
- 18.2. All flange and screw joints must be conductively connected during the assembly to provide protection against dangerous contact. 2 fan-shaped washers in galvanized version are to be used for conductive connection; they are to be situated under the head of one bolt and under the screwed nut.
- 18.3. If the damper is equipped with limit switches and the said devices are not used during operation (e.g. because of a project change), they can be left on the damper and not connected (they need not be dismantled). On the other hand, if a limit switch is to be added to the damper design, the change can be implemented by adding the required device to the base plate of the damper. The said facts must be recorded in the respective operation documentation of the damper (record books of the damper, fire logs, etc.) and subsequently, adequate function checks must be carried out.
- 18.4. The damper body should not be deformed in the course of bricking in. Once the damper is built in, its blade should not grind on the damper body during opening or closing.

Fig. 103 Potential flattening/ovality during installation process - Prevention

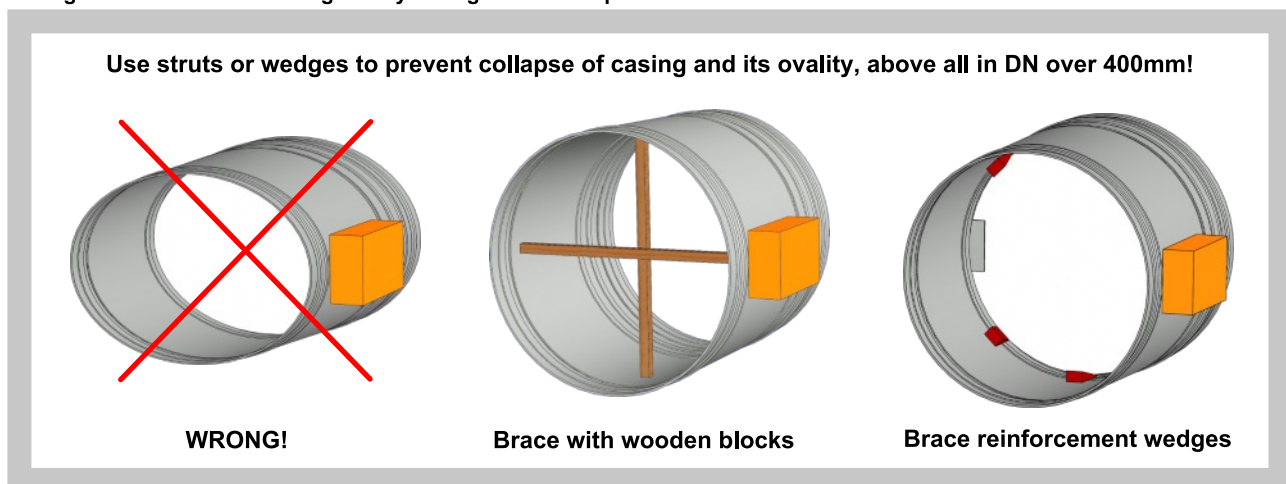

- 18.5. To ensure reliable fire damper function it is necessary to avoid blocking the closing mechanism and contact surfaces with collected dust, fibre and sticky materials and solvents.
- 18.6. Control of actuating mechanism without electric voltage:

You can set the damper blade in any position with the help of a special wrench (included in the delivery of the actuating mechanism). By turning the wrench in the direction of the arrow, the damper blade will move to the open position. By stopping the damper blade in any position, the actuating mechanism will be locked according to the instructions on the actuating mechanism. The mechanism can be unlocked manually according to the instructions on the mechanism or by means of supply voltage.

WARNING!

If the actuating mechanism is manually locked, the damper blade will not close in case of fire after activation of the thermoelectric starting mechanism BAT. To restore the correct function of the damper, the actuating mechanism must be unlocked (manually or by means of supply voltage).

19. Entry into service and revisions

- 19.1.** Before entering the dampers into operation after their assembly and by sequential checks, the following checks must be carried out. Visual inspection of proper damper integration , inside damper area, damper blade, contact surfaces and silicon sealing. Check of thermal protective fuse and closing mechanism. Check the closing function of the damper blade. This can be done by removing of thermal fuse from damper body.

Before entering the dampers with actuating mechanism into operation after their assembly and by sequential checks. Check of blade displacement into the breakdown position "CLOSED" can be done after cutting off the actuating mechanism supply (e.g. by pressing the RESET button at the thermoelectrical starting mechanism BAT or cutting off the supply from ELECTRICAL FIRE SIGNALISATION). Check of blade displacement back into the "OPEN" position can be done after restoration of power supply (e.g. by releasing the RESET button or restoration of supply from ELECTRICAL FIRE SIGNALISATION). Without power supply, the damper can be operated manually and fixed in any required position. Release of the locking mechanism can be achieved manually or automatically by applying the supply voltage. It is recommended to provide periodical checks, maintenance and service actions on Fire Equipment by Authorized persons. The authorized persons can be trained by Producer, or by authorized Distributor. All effective safety standards and directives must be observed during fire damper assembly.

For regular or exceptional inspection of interior of fire damper, micro-camera device can be used. On each fire damper is inspection hole. In the case of inspection by camera, take out the black rubber cap, insert the camera inside the damper, check interior and at the end of inspection, put the rubber cap back tightly to cover the empty hole.

- 19.2.** Before putting the dampers into operation and during subsequent function checks, the following checks must be carried out for all designs:

Visual check of correct installation of the damper, of the damper interior, of the damper blade, of the seating faces of the blade and of the silicone seal.

Disassembly of inspection hole cover: Remove the button-headed screws (2) and tilt the cover to take it out.

- 19.3.** For dampers with mechanical control (designs .01, .11, .80), the following checks must be carried out:

Check of closing mechanism and thermal fuse

To check the function of the mechanism proceed as follows:

Move the damper blade to "CLOSED" position as follows:

- The damper is in "OPEN" position.
- Press the control button of the mechanism to move the damper to "CLOSED" position.
- Check the damper blade shift to "CLOSED" position.
- The closing must be brisk; the control lever and the blade in the damper must be in "CLOSED" position.

Move the damper blade to "OPEN" position as follows:

- Turn the control lever by 90°.
- The lever will automatically lock in "OPEN" position.
- Check the damper blade shift to "OPEN" position.

Check of function and condition of the thermal fuse:

- To check the function and the condition of the thermal fuse, you can dismount the whole mechanism from the fire damper body - the mechanism is fixed to the damper body with four M6 screws.
- By removing the thermal fuse from the holder of the fuse of the starting mechanism, check its correct function.
- The mechanism size is marked with M1 to M5, according to the strength of the closing spring.

19.4. For the designs with actuating mechanisms, the following checks must be carried out:

Check the shift of the blade to "CLOSED" failure position after cutting off the power supply to the actuating mechanism (e.g. by pressing the reset button on the thermoelectric starting mechanism BAT, by cutting off the power supply from electrical fire signalization). Check the shift of the blade back to "OPEN" position by restoring the power supply to the actuating mechanism (e.g. by releasing the reset button, by restoring the power supply from electrical fire signalization).

19.5. The check of function of the damper with actuating mechanism can be carried out as follows:

- a) by cutting off and restoring the power supply, e.g. by a signal from electrical fire signalization
- b) directly on the installed damper, with the help of the button on the thermoelectric starting mechanism BAT (simulating fuse tripping).

19.6. Before putting the dampers into operation and during subsequent function checks, the following checks must be carried out for dampers with optical smoke detector, see section 19.1.:

The function checks of the optical smoke detector are to be carried out by employees of an authorized organization who have corresponding electrotechnical qualification and have been provably trained by the manufacturer. The function checks are to be carried out as a part of function checks of the fire dampers, at least 1x a year.

19.7. For the function checks, the dampers should be moved to "CLOSED" position with the fan off or with closed regulation valve situated between the fan and the fire damper.

20. Spare parts

20.1. Spare parts are supplied only on basis of an order.

21. Restore function of actuating mechanism after fuses initiation

21.1. If tripping of the thermal fuse Tf1 occurs (due to temperature around the fire damper), the actuating mechanism including the thermoelectric starting mechanism must be changed.

21.2. If tripping of the thermal fuse Tf2 occurs (due to temperature inside the piping), the self-standing spare part ZBAT72 or ZBAT95, respectively (according to actuating temperature), must be changed.

VIII. ORDERING INFORMATION

22. Ordering key

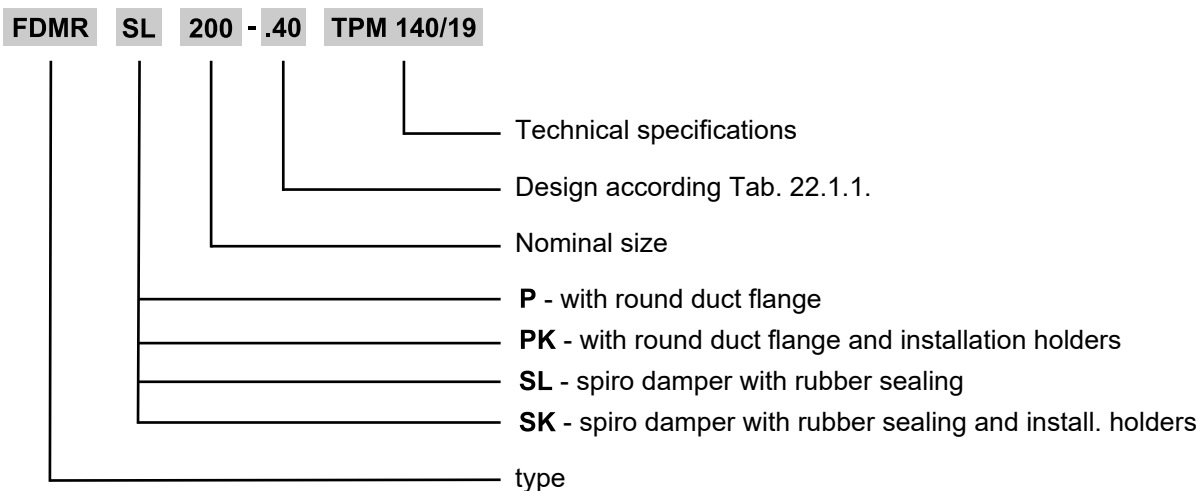

If dampers with installation frame are required, that must be separately specified in the purchase order.
The installation frame can be delivered installed on the damper or dismantled.

Tab. 22.1.1. Dampers design

Dampers design	Additional digit
Manual and thermal	.01
Manual and thermal (Zone 1,2)	.02
Manual and thermal with a terminal switch („CLOSED“)	.11
Manual and thermal with a terminal switch („CLOSED“) (Zone 1,2)	.12
With actuating mechanism BF 230-TN (BFL, BFN 230-T) - voltage AC 230 V	.40
With actuating mechanism BF 24-TN (BFL, BFN 24-T), with smoke detector ORS 142 K and with supply device BKN 230-24-MOD (voltage AC 230 V)	.41*
With actuating mechanism ExMax-15-BF (AC 230 V, AC/DC 24 V) with thermoelectric activation mechanism (Zone 1,2)	.42
With actuating mechanism BF 24-TN (BFL, BFN 24-T) - voltage AC/DC 24 V	.50
With actuating mechanism BF 24-TN (BFL, BFN 24-T), with smoke detector ORS 142 K (voltage AC/DC 24 V)	.51*
With communication and supply device BKN 230-24 and actuating mechanism BF 24-TN-ST (BFL, BFN 24-T-ST)	.60
With communication and supply device BKN 230-24-C-MP, with actuating mechanism BF 24-TN-ST (BFL, BFN 24-T-ST) and with smoke detector ORS 142 K	.61*
With communication and supply device BKN 230-24MP and with actuating mechanism BF 24TL-TN-ST (Top-Line) for connection to MP-Bus	.62
With communication and supply device BKN 230-24-MOD, with actuating mechanism BF 24-TN-ST (BFL, BFN 24-T-ST) and with smoke detector ORS 142 K	.63*
With communication and supply device BKN 230-24LON and with actuating mechanism BF 24TL-TN-ST (Top-Line) for connection to LonWorks	.64
Manual and thermal with two terminal switches („OPEN“, „CLOSED“)	.80
Manual and thermal with two terminal switches („OPEN“, „CLOSED“) (Zone 1,2)	.81

* The smoke detector sensor is not part of the fire damper in the case of dampers in diameters from DN 100 mm to DN 200 mm (including). The smoke sensor is supplied separately.

IX. PRODUCT DATA

23. Data label

23.1. Data label is placed on the damper body.

Fig. 104 Data label

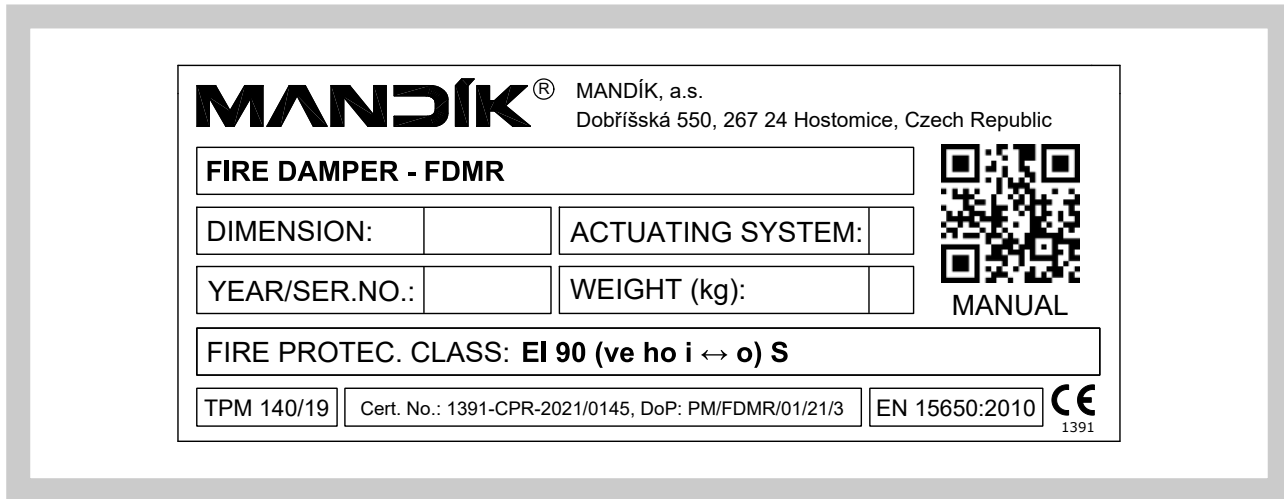

MANDÍK, a.s.
 Dobříšská 550
 26724 Hostomice
 Czech Republic
 Tel.: +420 311 706 706
 E-Mail: mandik@mandik.cz
 www.mandik.com

The producer reserves the right for innovations of the product. For actual product information see www.mandik.com