

EN 15650:2010-09

# MANDÍK<sup>®</sup>

## FIRE DAMPER CFDM and CFDM-V

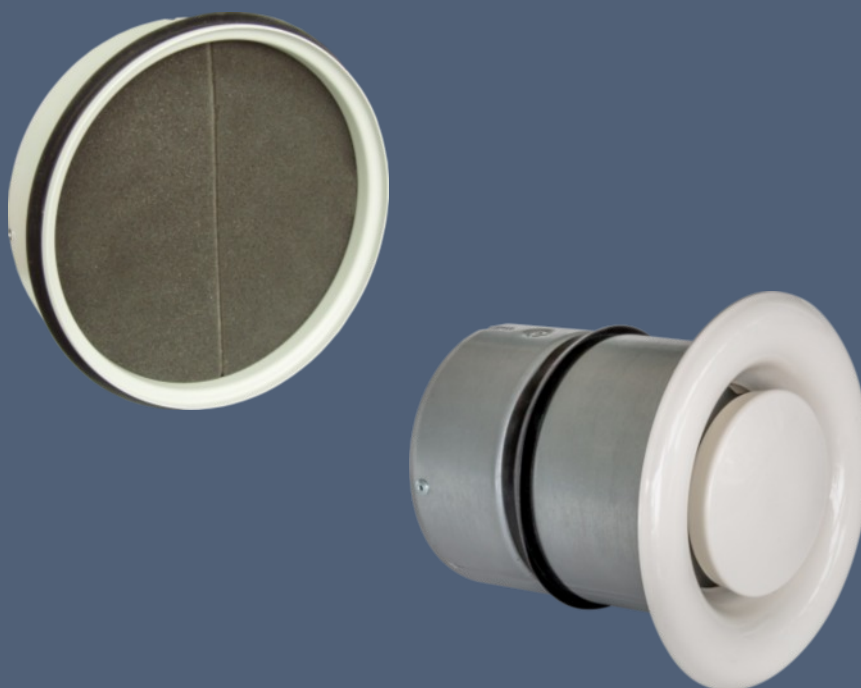

These technical specifications state a row of manufactured sizes and models of fire dampers (further only dampers) CFDM / CFDM-V. It is valid for production, designing, ordering, delivery, assembly and operation.

**I. CONTENT**

<b>II. GENERAL INFORMATION</b>	<b>3</b>
1. Description.....	3
2. Damper design.....	4
3. Dimensions, weights.....	5
4. Placement and Assembly.....	6
5. Statement of installations.....	8
<b>III. TECHNICAL DATA</b>	<b>17</b>
6. Pressure loss of CFDM.....	17
7. Coefficient of local pressure loss of CFDM.....	17
8. Basic parameters of CFDM-V.....	18
<b>IV. MATERIAL, FINISHING</b>	<b>21</b>
9. Material.....	21
<b>V. INSPECTION, TESTING</b>	<b>21</b>
10. Inspection, testing.....	21
<b>VI. TRANSPORTATION AND STORAGE</b>	<b>21</b>
11. Logistic terms.....	21
<b>VII. ASSEMBLY, ATTENDANCE, MAINTENANCE AND REVISIONS</b>	<b>21</b>
12. Assembly.....	21
13. Entry into service and revisions.....	21
<b>VIII. DATA OF PRODUCT</b>	<b>22</b>
14. Data label.....	22
15. Quick review.....	22
<b>IX. ORDERING INFORMATION</b>	<b>23</b>
16. Ordering key.....	23

## II. GENERAL INFORMATION

### 1. Description

- 1.1. Fire dampers are shutters in duct systems of air-conditioning devices that prevent spreading the fire and combustion products from one fire segment to the other one by means of closing the air duct in the points of fire separating constructions.

Dampers blade automatically closes air duct using a shutting spring.

The damper is sealed with a plastic foam packing against smoke penetration after closing the blade. At the same time, the damper blade is bedded in a material which enlarges its capacity and air-proofs the air duct.

Fire damper can be directly equipped with the dish valve in both combinations - exhaust (TVOM) and supply (TVPM). The valve is fixed in the damper body by springs and can be easily put out from the damper. In the case the fire damper was extended casing.

Fig. 1 CFDM



Fig. 2 CFDM-V with supply and exhaust dish valve



- 1.2. Damper characteristics

- CE certified acc. to EN 15650
- Tested in accordance with EN 1366-2
- Classified acc. to EN 13501-3+A1
- Fire resistance EIS 120, EIS 90, EIS 60
- Internal leakage class 2 acc. to EN 1751, external leakage is equal to ducting system
- Corrosion resistant acc. to EN 15650
- ES Certificate No. 1391-CPR-2018/0129
- Declaration of Performance No. PM/CFDM/01/20/1, PM/CFDM-V/01/20/1
- Hygienic assessment of fire dampers - Report No. 1.6/pos/19/19b

- 1.3. Working conditions

Exact damper function is provided under the following conditions:

- a) Maximum air circulation speed: 12 m/s  
Maximum pressure difference: 1200 Pa
- b) The air circulation in the whole damper section must be secured as steady on whole surface.

Operation of the damper does not depend on the direction of air circulation. The dampers can be located in an arbitrary position.

Dampers are suitable for ventilation systems, where air does not contain any abrasive, chemical or adhesive particles.

Dampers are designed for macroclimatic areas with mild climate according to EN 60 721-3-3. Temperature in the place of installation is permitted to range from -30°C to +50°C.

**2. Damper design**

**2.1. Design with mechanical control**

**Design .01**

Design with mechanical control with a thermal protective fuse (inner mechanical control) which actuates the shutting device within 120 seconds at latest after the nominal start temperature 72°C has been reached. Automatic initiation of the shutting device is not activated if the temperature does not exceed 70°C.

By CFDM, CFDM-V the design .01 with mechanical control can be equipped by one or two limit switches signalling position of the damper blade "CLOSED".

Fig. 3 CFDM



Fig. 4 CFDM-V with dish valve

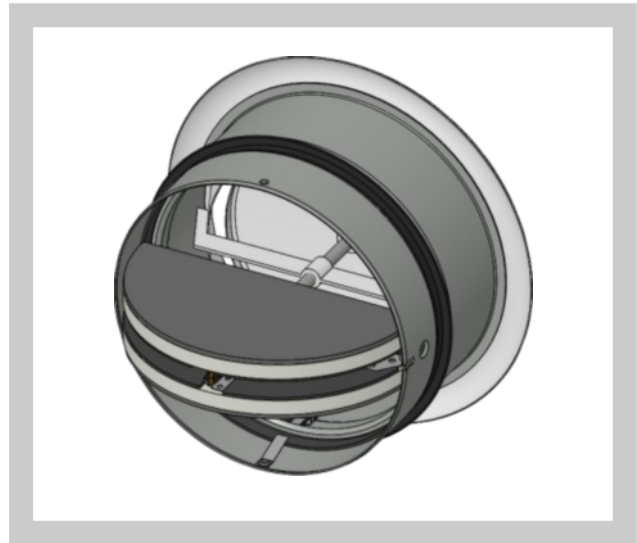

**Design .11, .15**

Design .01 with mechanical control can be equipped by one or two limit switches signalling position of the damper blade "CLOSED". Connection wires of the end-switches of CFDM fire dampers are done through the bushing opening in the air-duct. In the case of CFDM-V dampers (fire damper with integrated air-valve), it is possible to connect the end-switches appropriately around the valve or through the hole in the body, air-duct and in the construction.

Fig. 5 CFDM - limit switches

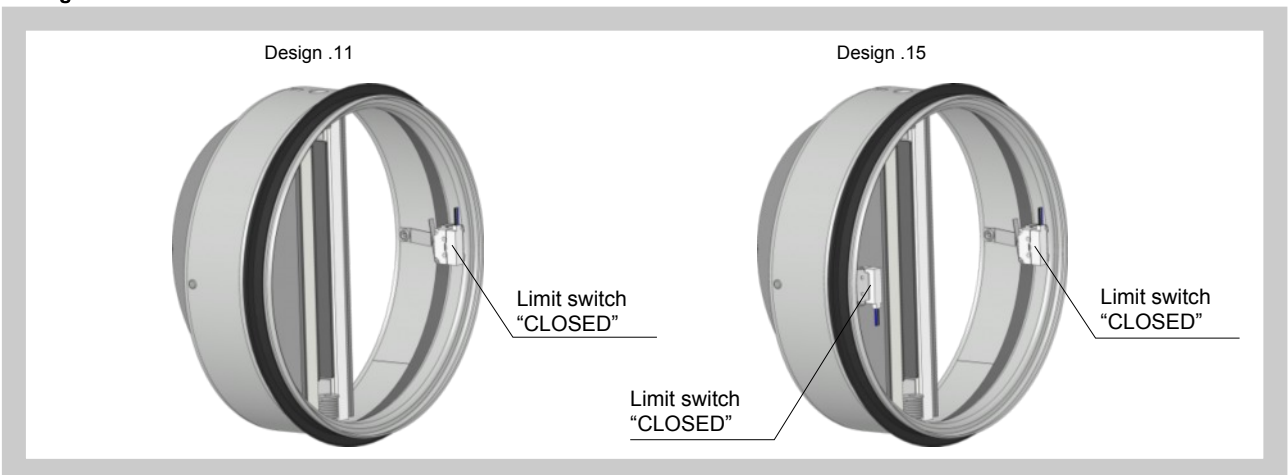

**2.2. Design according to fire resistance**

- EIS 120
- EIS 90
- EIS 60

Fig. 6 Limit switch G905-300E05W1

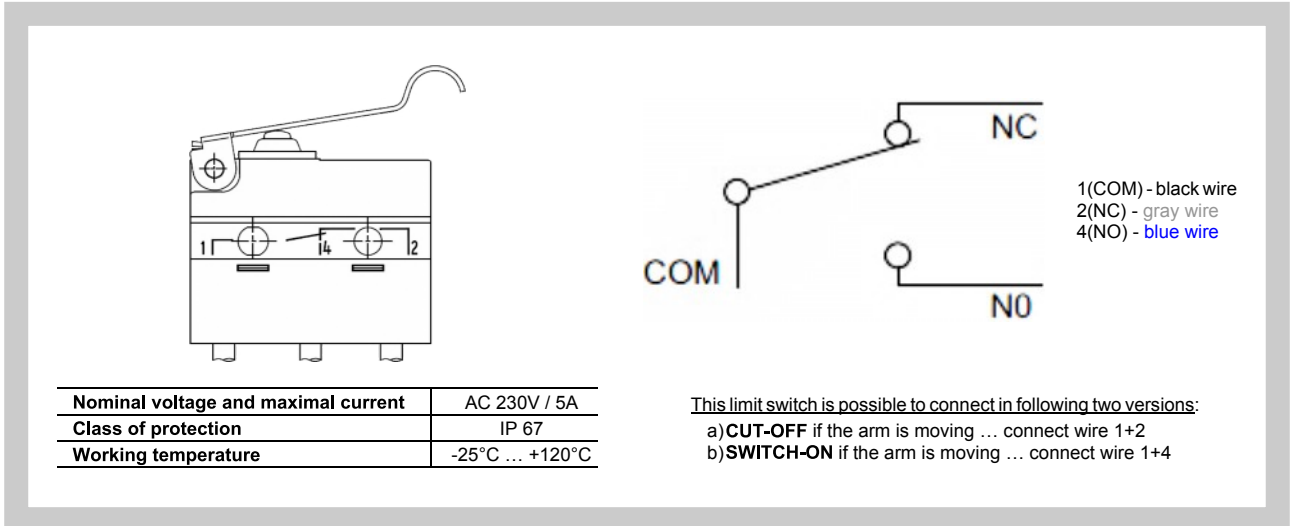

3. Dimensions, weights

3.1. Dimensions

Fig. 7 CFDM

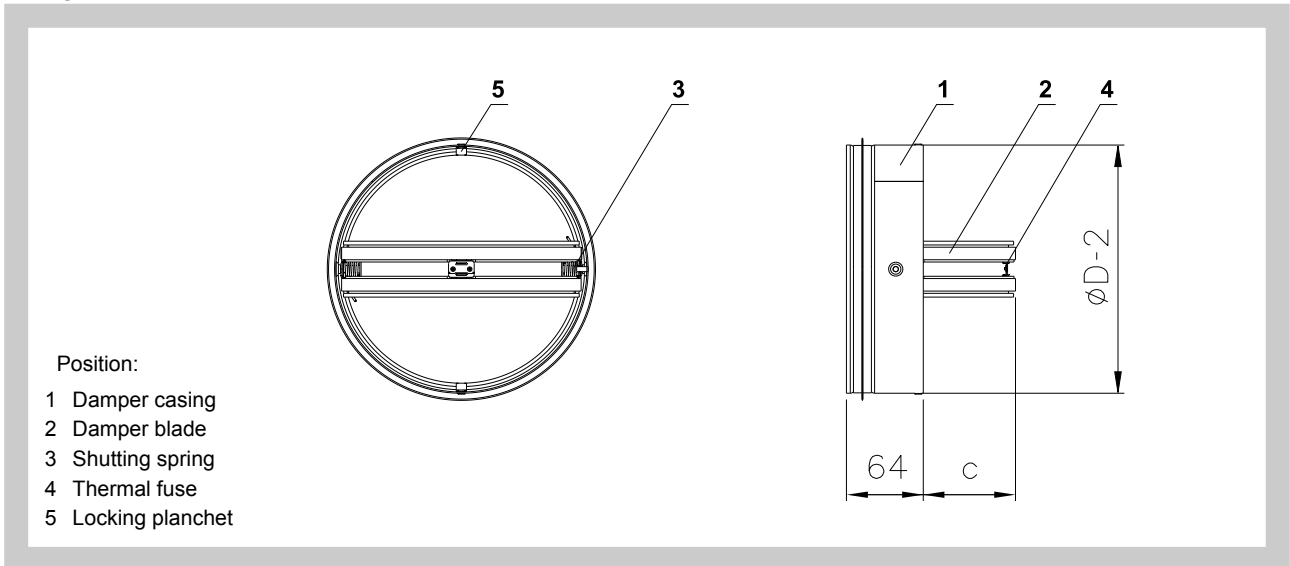
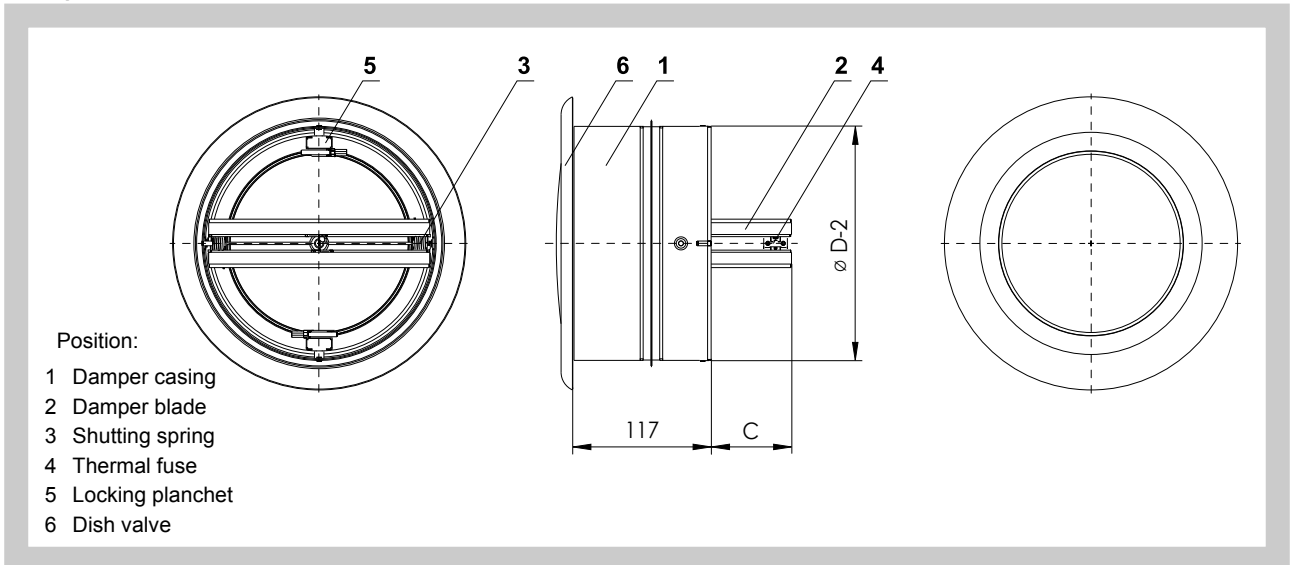

Fig. 8 CFDM-V with dish valve



3.2. Weights and effective area CFDM / CFDM-V

Tab. 3.2.1. Weights and effective area CFDM / CFDM-V

Size $\varnothing D$ [mm]	Weight CFDM [kg]	Weight CFDM-V * [kg]	Weight TVPM [kg]	Weight TVOM [kg]	Effective area $S_{ef}$ [m <sup>2</sup> ]	Blade overlap "c" [mm]
100	0,3	0,45	0,19	0,17	0,0030	17,5
125	0,4	0,58	0,27	0,23	0,0060	30,2
160	0,55	0,79	0,42	0,38	0,0119	48
200	0,75	1	0,59	0,51	0,0209	68

\* It is necessary to add the weight of selected dish valve to the CFDM-V (TVPM or TVOM).

4. Placement and assembly

4.1. Fire dampers are suitable for installation in arbitrary position in vertical and horizontal passages of fire separating constructions. Duct assembly procedures must be done so as all load transfer from the fire separating constructions to the duct in the placement of fire damper installation is absolutely excluded. Installation gap must be filled by approved material perfectly in all the installation space volume (installation gap).

To provide needed access space to the control device, all other objects must be situated at least 350 mm from the control parts of the damper. Inspection hole must be accessible.

**Notice:** Damper has to be accessible for regular checks and maintenance.

Fire damper is inserted inside the duct. Blade has to be inside of fire separating construction (after closing).

The distance between the fire damper and the construction (wall, ceiling) must be at least 75 mm. In case that two or more dampers are supposed to be installed in one fire separating construction, the distance between the adjacent dampers must be at least 200 mm according to EN 1366-2 paragraph 13.5.

Fig. 9 Construction

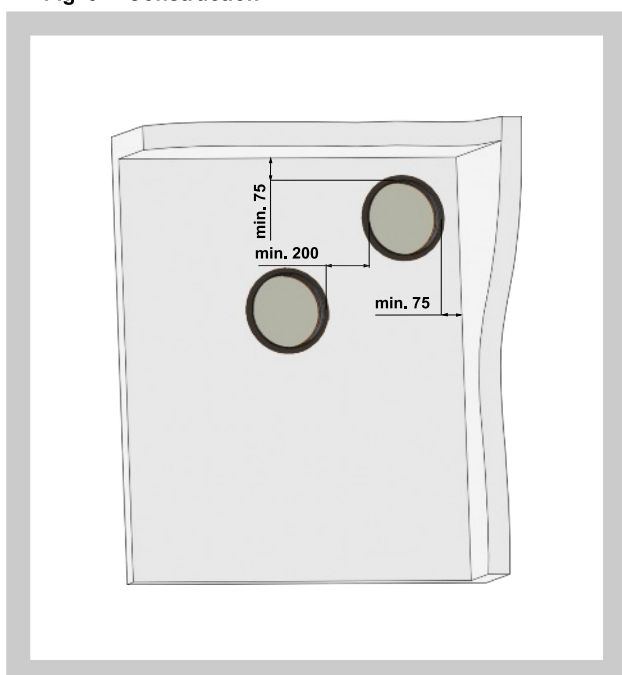
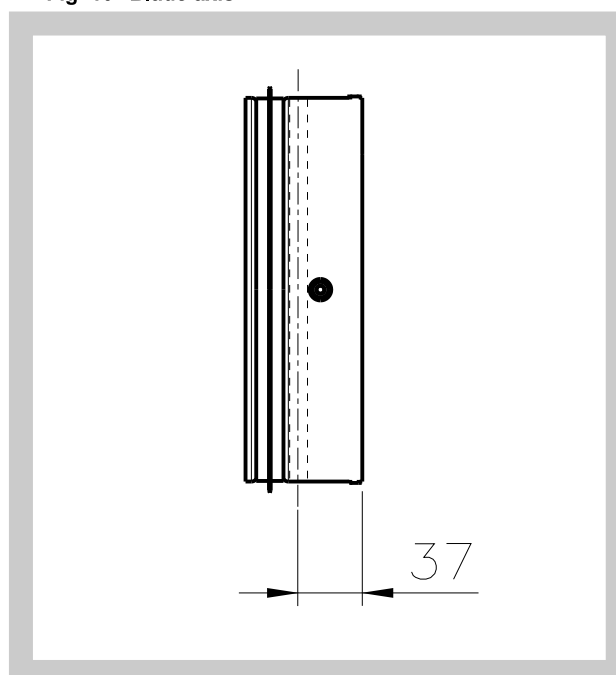
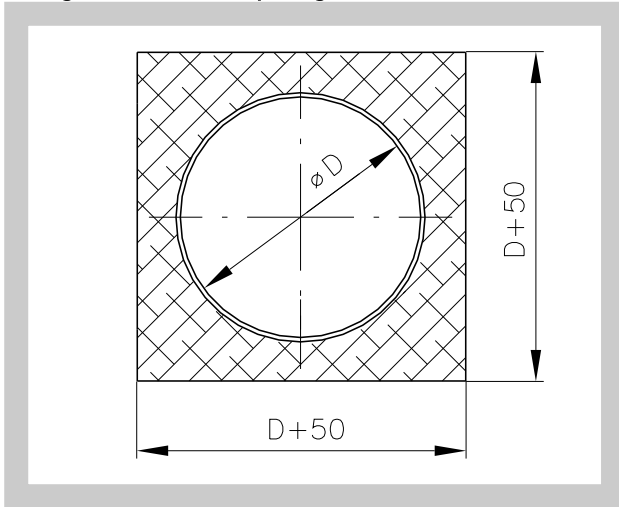

Fig. 10 Blade axis



**4.2. Installation opening dimensions**

**Fig. 11 Installation opening**



**Fig. 12 Installation opening**

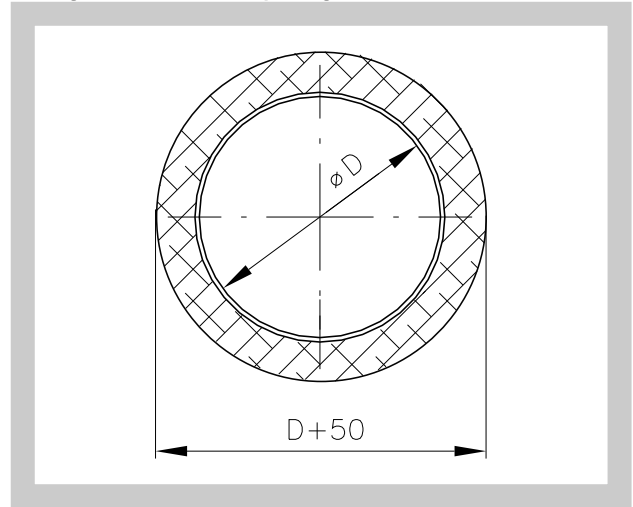

**Fig. 13 Installation opening - mineral wool boards with fire resistant coating**

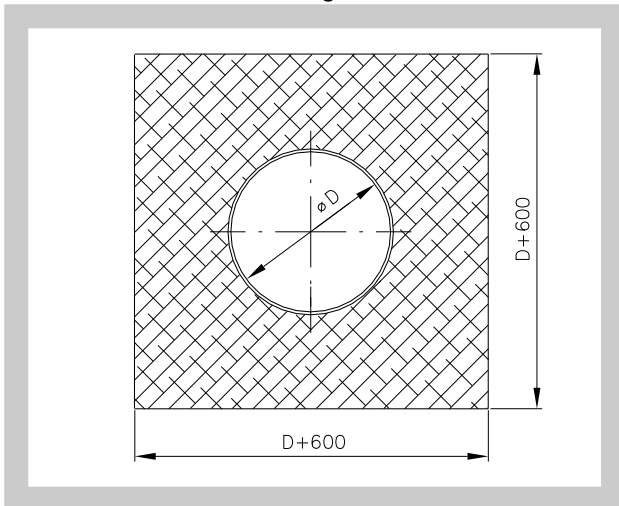

**4.3. Examples of fire damper installing**

The fire damper can be integrated into a solid wall construction made e.g. of normal concrete/ masonry, porous concrete with minimum thickness 100 mm or into solid ceiling construction made e.g. of normal concrete with minimum thickness 110 mm or porous concrete with minimum thickness 125 mm.

The fire damper can be integrated into a gypsum wall construction with fire classification EI 120 or EI 90.

5. Statement of installations

5.1. Statement of installations the fire dampers CFDM / CFDM-V

Tab. 5.1.1. Statement of installations the fire dampers

Construction	Installation	Material of stuffing box	Figure
Solid wall construction	Wet	mortar or gypsum	14
	Dry	mineral wool boards with fire resistant coating	15
	Dry	Mineral stone wool with fire stop coating and cement lime plate	16
Gypsum wall construction	Wet	mortar or gypsum	17
	Dry	mineral wool boards with fire resistant coating	18
	Dry	Mineral stone wool with fire stop coating and cement lime plate	19
Solid ceiling construction	Wet	mortar or gypsum	20
	Dry	mineral wool boards with fire resistant coating	21

Fig. 14 Solid wall construction - mortar or gypsum

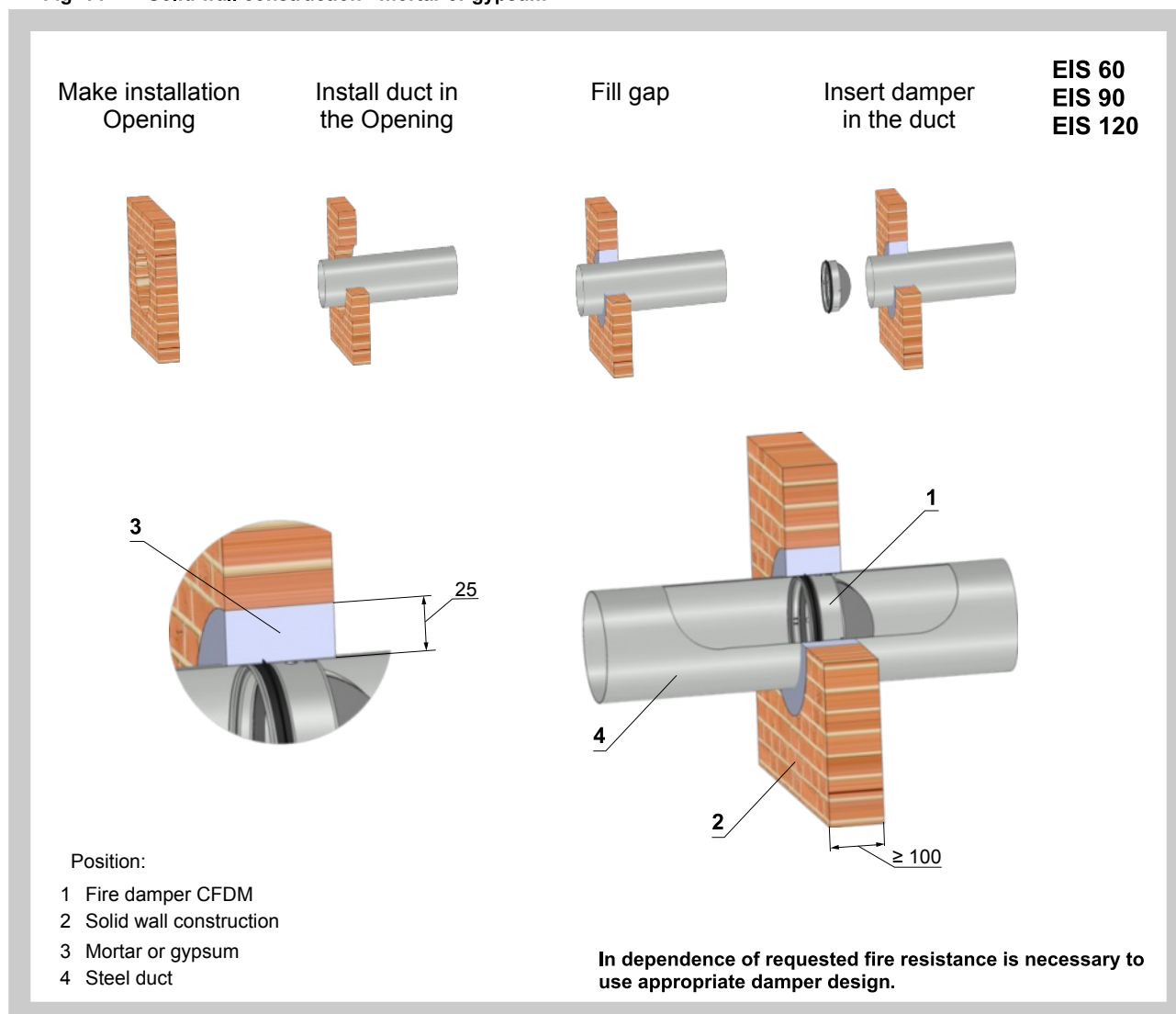



Fig. 15 Solid wall construction - mineral wool boards with fire resistant coating

EIS 60  
EIS 90

Make installation  
Opening



Install duct  
in the Opening

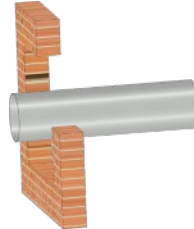

Fill gap and cover  
duct by fire resistant  
coating

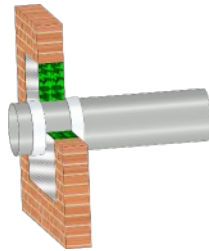

Insert damper  
in the duct

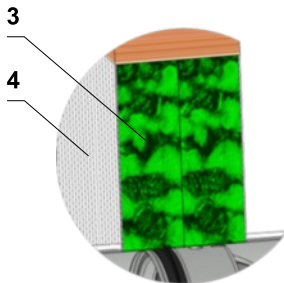
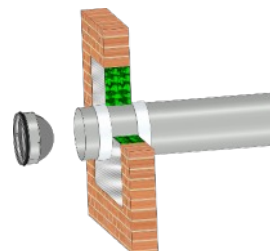

D+60 to 800  
max. 2050

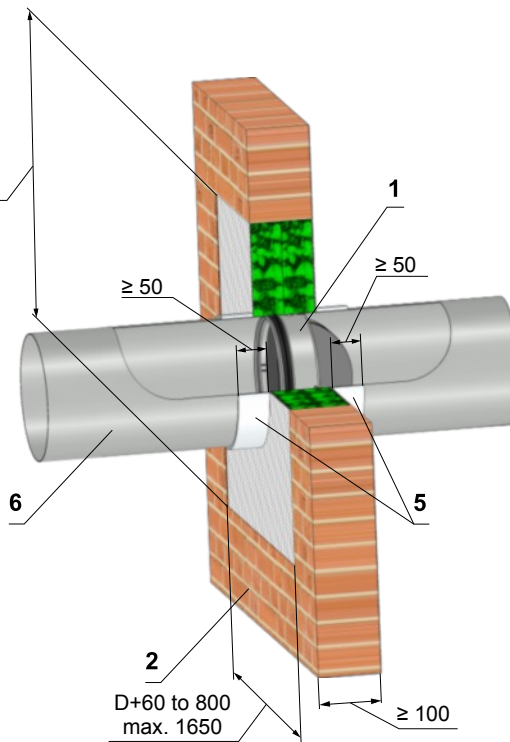

Used materials - example\*:

- 3 - Hilti CFS-CT B 1S 140/50
- 4 - Hilti CFS-CT

Position:

- 1 Fire damper CFDM
- 2 Solid wall construction
- 3 Fire resistant board
- 4 Fire stop coating thickness 1 mm
- 5 Glass fiber felt with aluminium foil width 50 mm, thickness 5 mm
- 6 Steel duct

**Notice:**

\* Fire resistant board and fire stop coating can be replaced by another approved fire sealing system for damper installation with equivalent material properties.

**In dependence of requested fire resistance is necessary to use appropriate damper design.**

Fig. 16 Solid wall construction - mineral stone wool with fire stop coating and cement lime plate

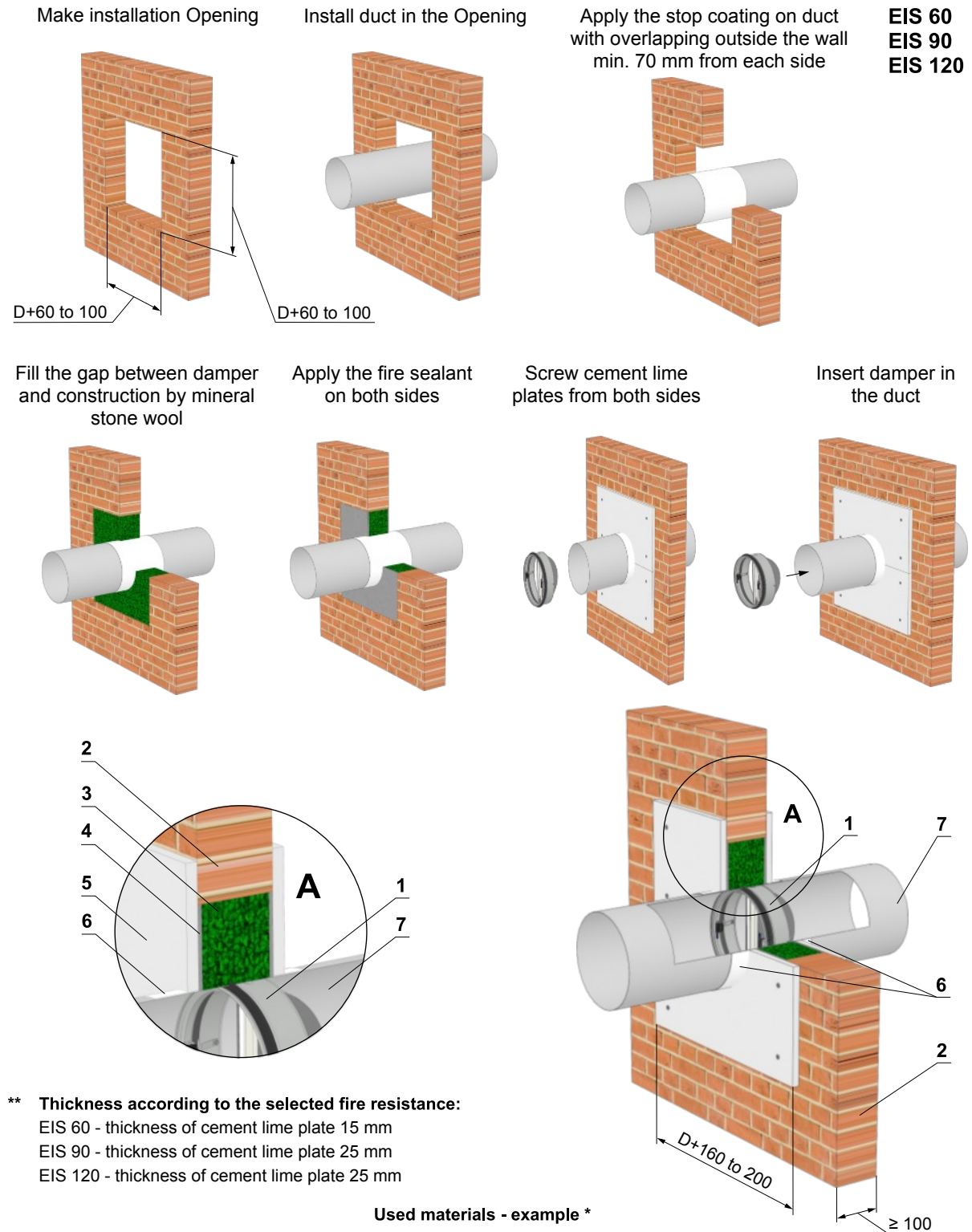

EIS 60  
EIS 90  
EIS 120

\*\* Thickness according to the selected fire resistance:  
EIS 60 - thickness of cement lime plate 15 mm  
EIS 90 - thickness of cement lime plate 25 mm  
EIS 120 - thickness of cement lime plate 25 mm

Used materials - example \*  
3 - Mineral stone wool min. density 65 kg/m<sup>3</sup>  
4 - PROMASTOP-P (-I), Hilti CFS-S ACR  
6 - PROMASTOP-E (-CC), Hilti CFS-CT

- Position:
- 1 Fire damper CFDM
  - 2 Solid wall construction
  - 3 Mineral stone wool
  - 4 Fire sealant thickness 1 mm
  - 5 Cement lime plate in min. density 500 kg/m<sup>3</sup> \*\*
  - 6 Fire stop coating thickness 1 mm
  - 7 Duck

**Notice**  
\* Fire resistant board and fire stop coating can be replaced by another approved fire sealing system for damper installation with equivalent material properties.  
**In dependence of requested fire resistance is necessary to use appropriate damper design.**

Fig. 17 Gypsum wall construction - mortar or gypsum

EIS 60  
EIS 90  
EIS 120

Make installation  
Opening

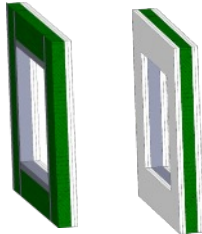

Install duct in  
the Opening

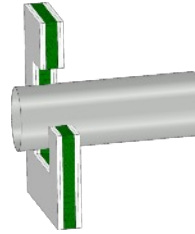

Fill gap

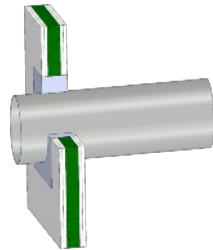

Insert damper  
in the duct

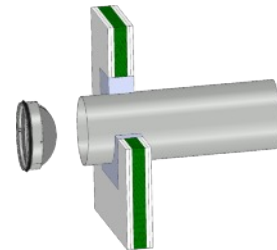

Installation opening has to be reinforced by profile (UW, CW). Profil is fixed by screws  $\geq 3,5$  mm with corresponding length. Distance between screws  $\leq 200$  mm.

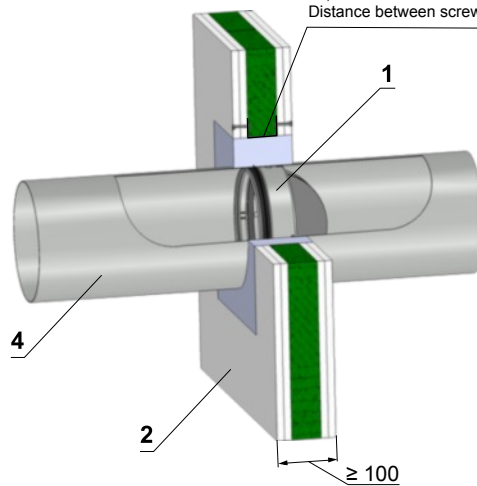
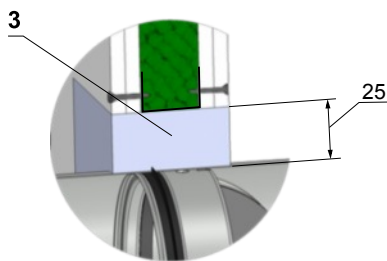

Position:

- 1 Fire damper CFDM
- 2 Solid wall construction
- 3 Mortar or gypsum
- 4 Steel duct

In dependence of requested fire resistance is necessary to use appropriate damper design.

Fig. 18 Gypsum wall construction - mineral wool boards with fire resistant coating

EIS 60  
EIS 90

Make installation  
Opening

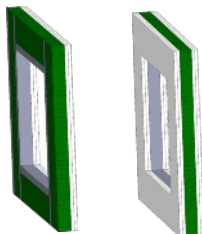

Install duct in  
the Opening

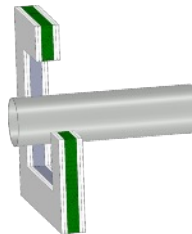

Fill gap and cover  
duct by fire resistant  
coating

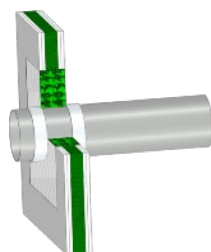

Insert damper  
in the duct

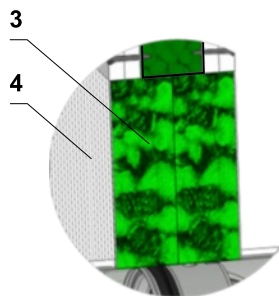
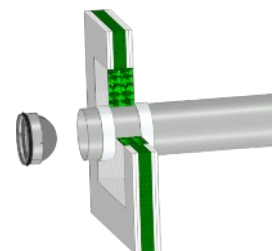

D+60 to 800  
max. 2050

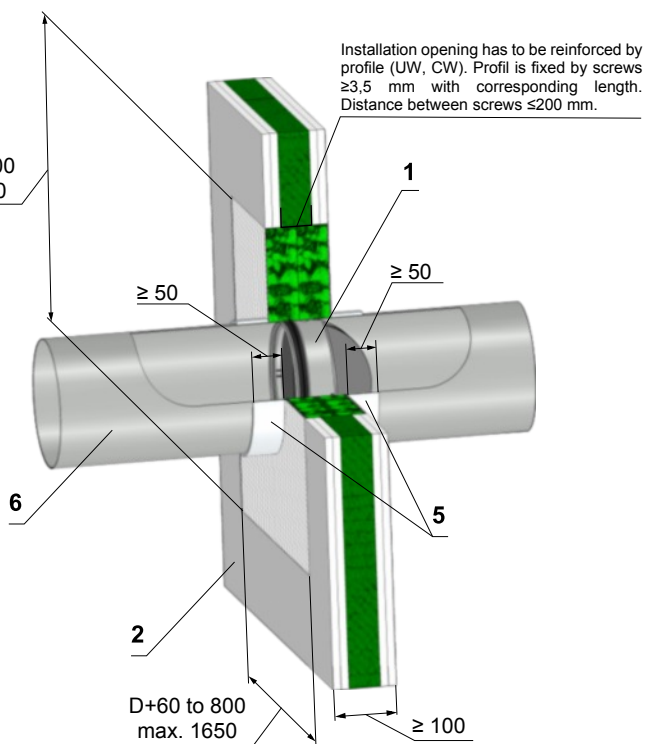

Used materials - example\*:

- 3 - Hilti CFS-CT B 1S 140/50
- 4 - Hilti CFS-CT

Position:

- 1 Fire damper CFDM
- 2 Gypsum wall construction
- 3 Fire resistant board
- 4 Fire stop coating thickness 1 mm
- 5 Glass fiber felt with aluminium foil width 50 mm, thickness 5 mm
- 6 Steel duct

**Notice:**

\* Fire resistant board and fire stop coating can be replaced by another approved fire sealing system for damper installation with equivalent material properties.

**In dependence of requested fire resistance is necessary to use appropriate damper design.**

Fig. 19 Gypsum wall construction – mineral stone wool with fire stop coating and cement lime plate

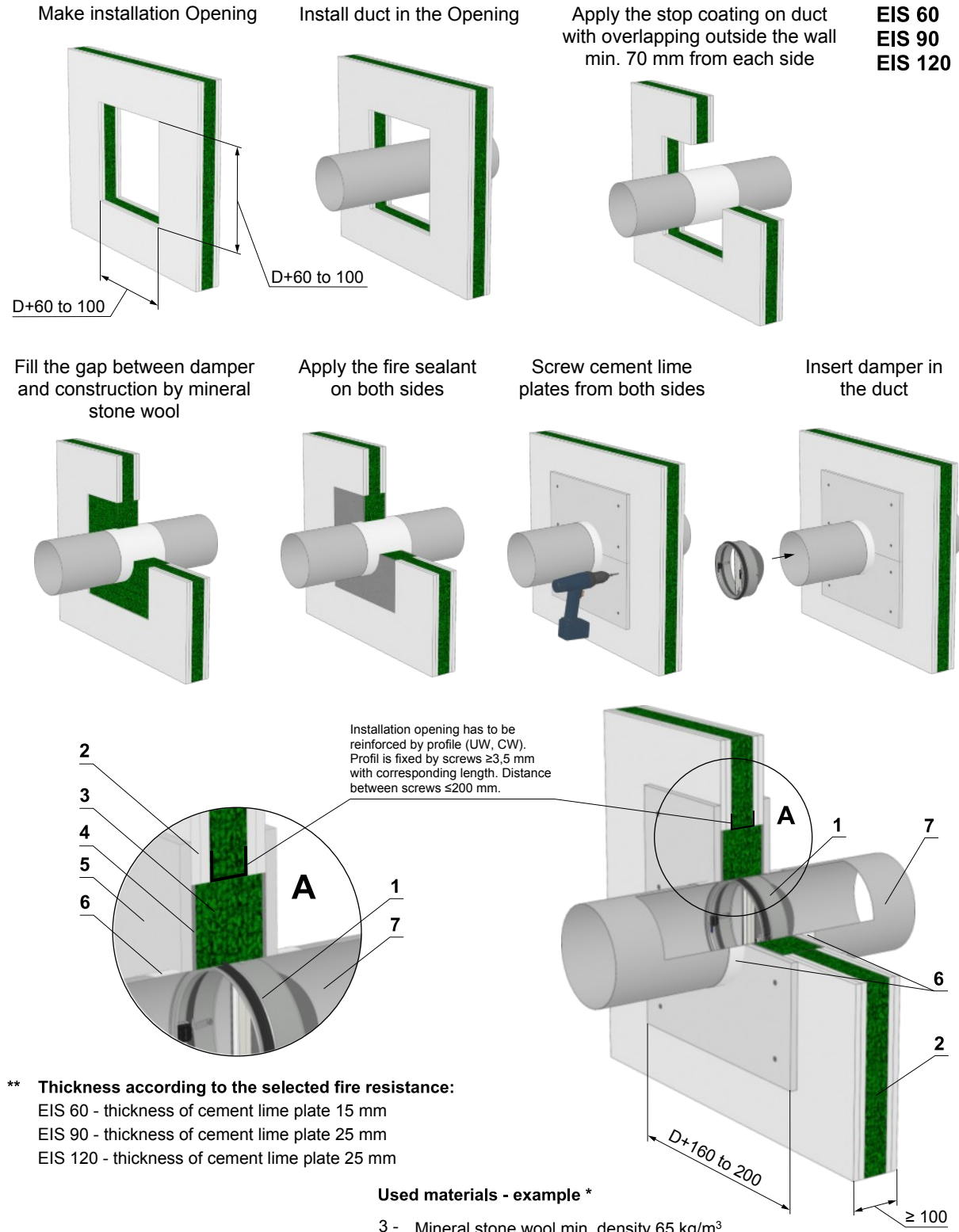

- Position:
- 1 Fire damper CFDM
  - 2 Gypsum wall construction
  - 3 Mineral stone wool
  - 4 Fire sealant thickness 1 mm
  - 5 Cement lime plate in min. density 500 kg/m<sup>3</sup> \*\*
  - 6 Fire stop coating thickness 1 mm
  - 7 Duck

**Notice**

\* Fire resistant board and fire stop coating can be replaced by another approved fire sealing system for damper installation with equivalent material properties.

**In dependence of requested fire resistance is necessary to use appropriate damper design.**

Fig. 20 Solid ceiling construction - mortar or gypsum

EIS 60  
EIS 90

Make installation  
Opening

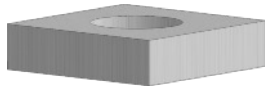

Install duct in  
the Opening

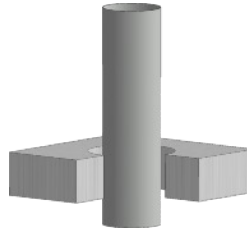

Fill gap

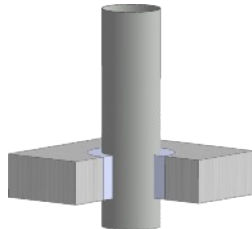

Insert damper  
in the duct

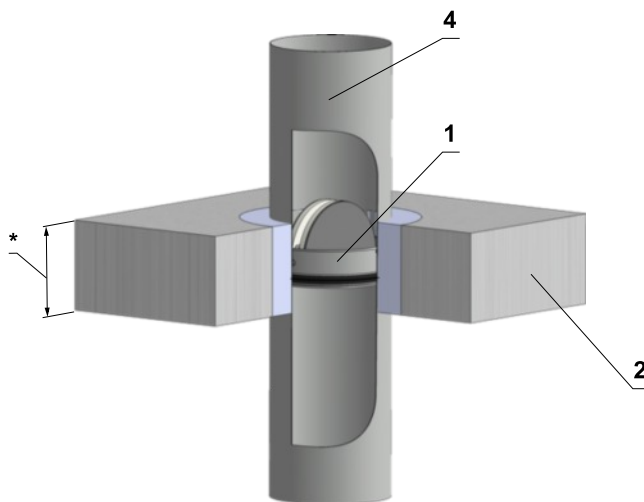
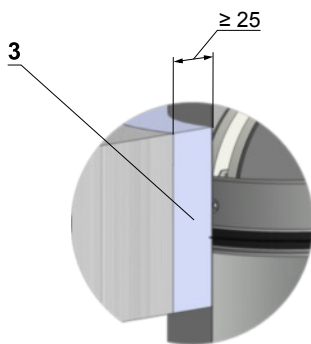
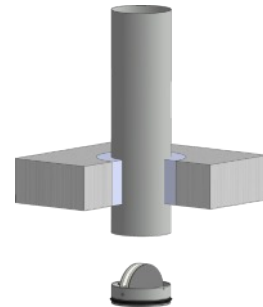

Position:

- 1 Fire damper CFDM
- 2 Solid wall construction
- 3 Mortar or gypsum
- 4 Steel duct

\* min. 110 - Concrete/ min. 125 - Aerated concrete

**In dependence of requested fire resistance is necessary to use appropriate damper design.**

Fig. 21 Solid ceiling construction - mineral wool boards with fire resistant coating

EIS 60  
EIS 90

Make installation  
Opening



Install duct in  
the Opening

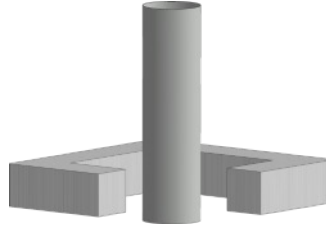

Fill gap and cover  
duct by fire resistant  
coating

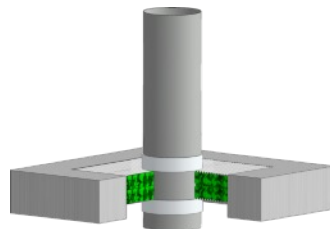

Insert damper  
in the duct

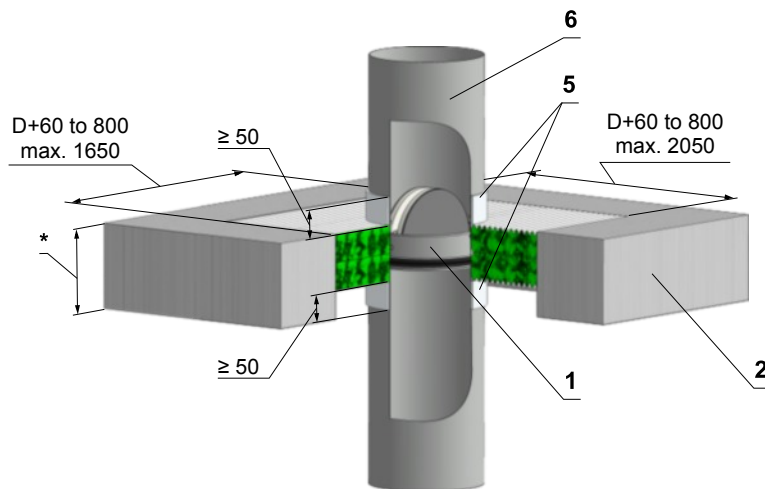
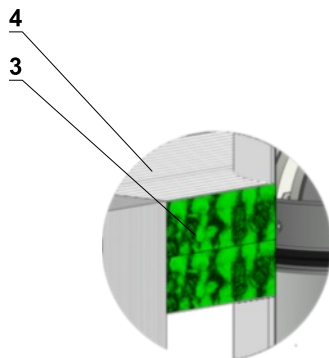
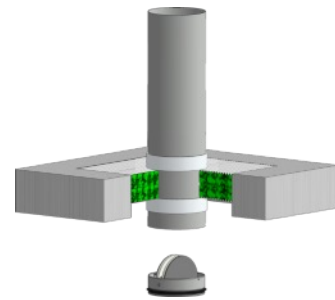

\* min. 110 - Concrete/ min. 125 - Aerated concrete

Used materials - example\*\*:

- 3 - Hilti CFS-CT B 1S 140/50
- 4 - Hilti CFS-CT

Position:

- 1 Fire damper CFDM
- 2 Ceiling wall construction
- 3 Fire resistant board
- 4 Fire stop coating thickness 1 mm
- 5 Glass fiber felt with aluminium foil width 50 mm, thickness 5 mm
- 6 Steel duct

**Notice:**

\*\* Fire resistant board and fire stop coating can be replaced by another approved fire sealing system for damper installation with equivalent material properties.

**In dependence of requested fire resistance is necessary to use appropriate damper design.**



Fig. 22 Installation with dish valve

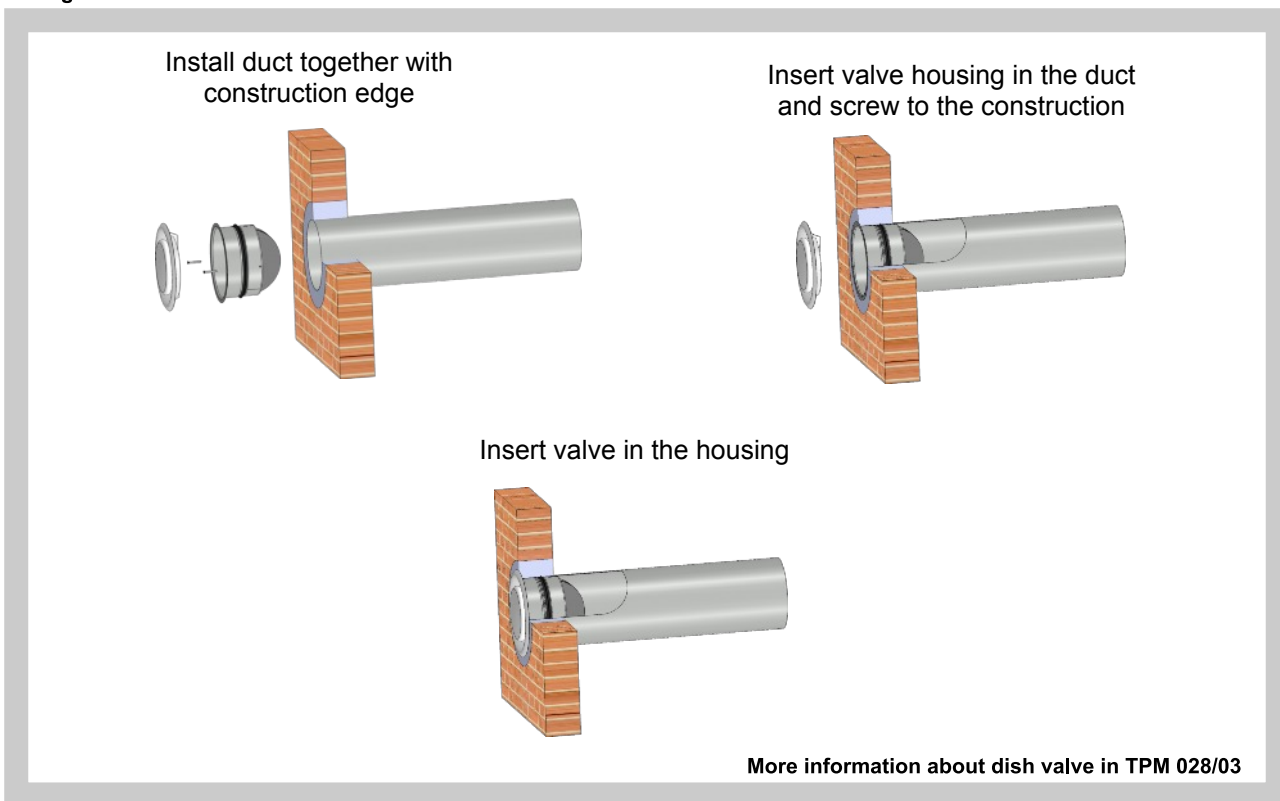
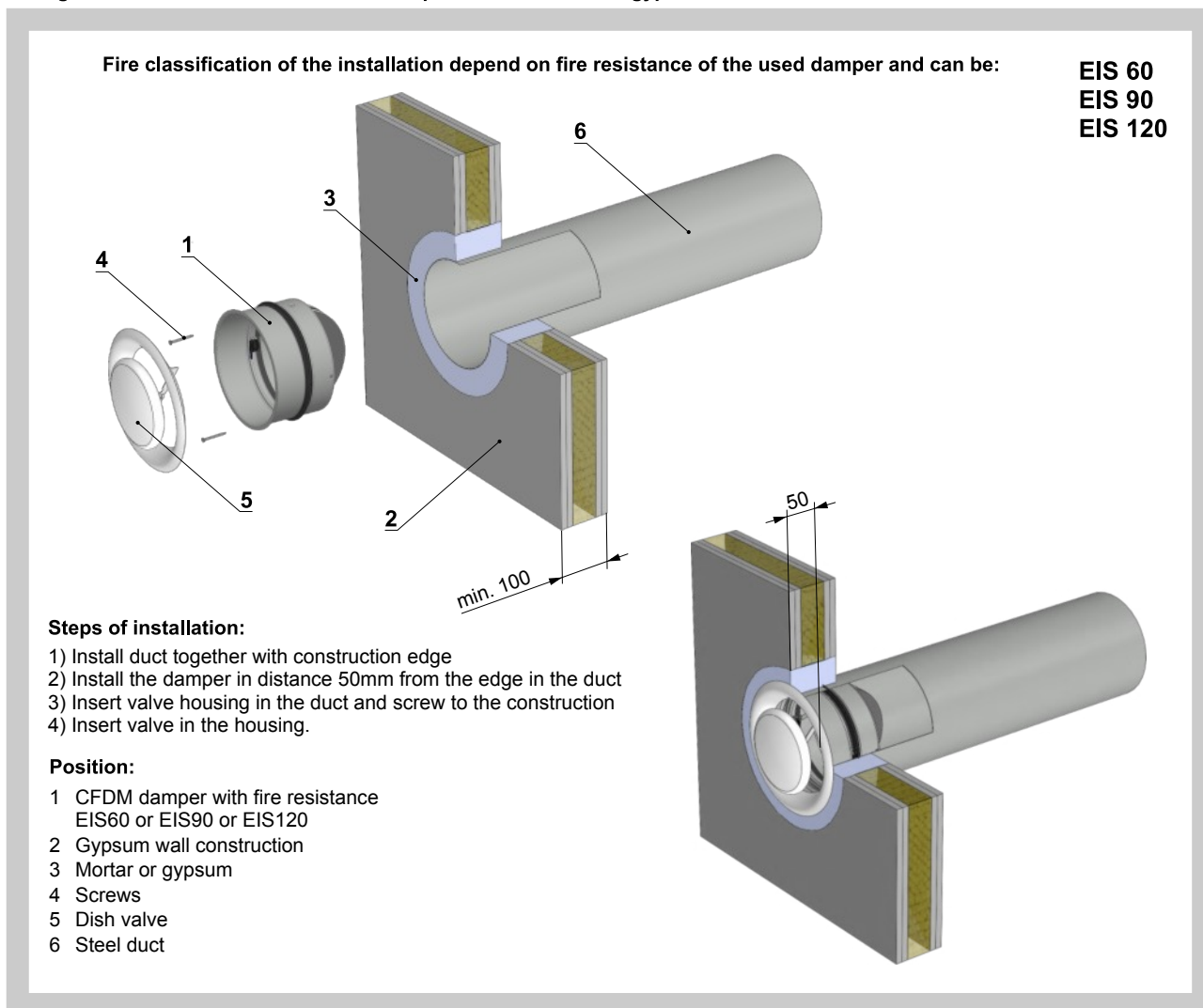

Fig. 23 Installation of the CFDM damper with dish valve in gypsum wall construction





**III. TECHNICAL DATA**

**6. Pressure loss of CFDM**

**6.1. Pressure loss calculation**

$$\Delta p = \xi \cdot \rho \cdot \frac{w^2}{2}$$

- $\Delta p$  [Pa]      pressure loss
- $w$  [m.s<sup>-1</sup>]    air flow speed in nominal damper section
- $\rho$  [kg.m<sup>-3</sup>]    air density
- $\xi$  [-]          coefficient of local pressure loss for the nominal damper section

**6.2. Determination of pressure loss by using Diagram 1  $\rho = 1,2 \text{ kg.m}^{-3}$  and noise data**

**Diagram 1      Pressure losses for air density  $\rho = 1,2 \text{ kg.m}^{-3}$**

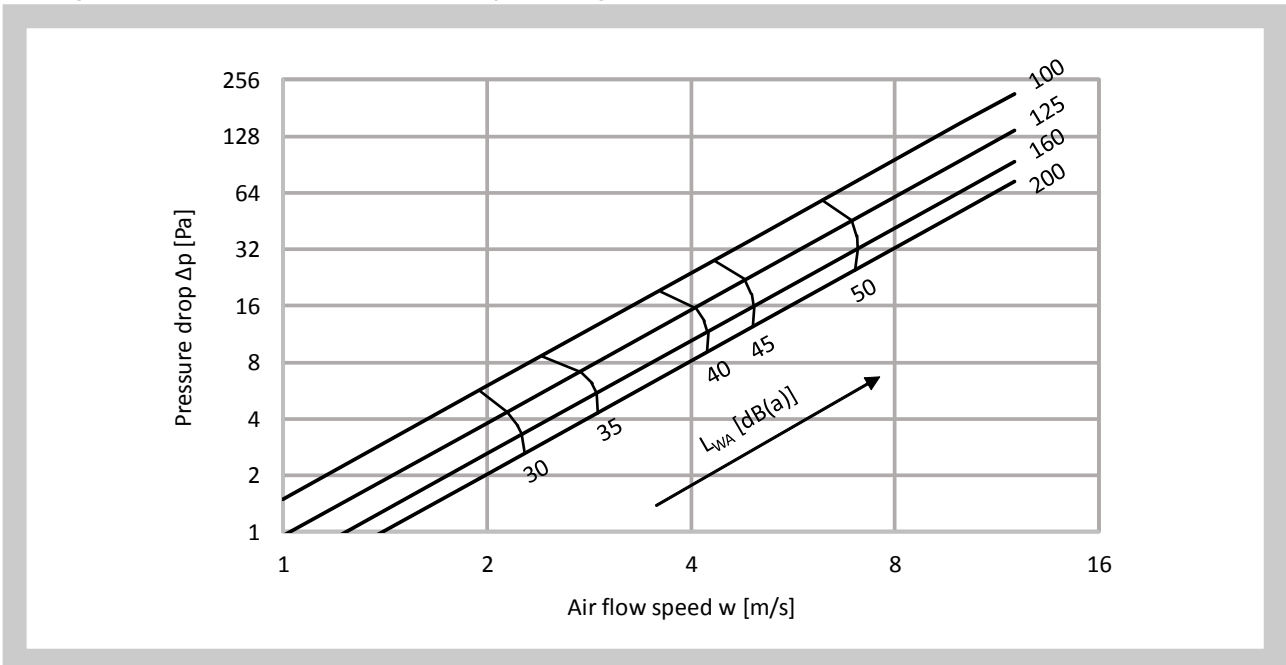

**7. Coefficient of local pressure loss of CFDM**

**7.1. Coefficient of local pressure loss  $\xi$  (-)**

**Tab. 7.1.1. Coefficient of local pressure loss [m/s]**

<b>D</b>	<b>100</b>	<b>125</b>	<b>160</b>	<b>200</b>
$\xi$	2,502	1,591	1,086	0,848

**8. Basic parameters of CFDM-V**

**8.1. Basic data**

$\dot{V}$	[m <sup>3</sup> .h <sup>-1</sup> ]	volumetric air flow per one damper
s	[mm]	distance of valve disc from zero position
$\Delta p_c$	[Pa]	pressure loss at $\rho = 1,2 \text{ kg/m}^3$
$L_{wa}$	[dB(A)]	level of acoustic power

**Tab. 8.1.1. Fire damper CFDM-V with exhaust dish valve**

Size	100	125	160	200
$\dot{V}_{max}$ [m <sup>3</sup> .h <sup>-1</sup> ]	90	150	200	250

**Tab. 8.1.2. Fire damper CFDM-V with supply dish valve**

Size	100	125	160	200
$\dot{V}_{max}$ [m <sup>3</sup> .h <sup>-1</sup> ]	90	150	200	250

8.2. Pressure loss and sound data of CFDM-V

8.2.1. Damper with valve for air supply TVPM

Diagram 2 CFDM-V - TVPM 100

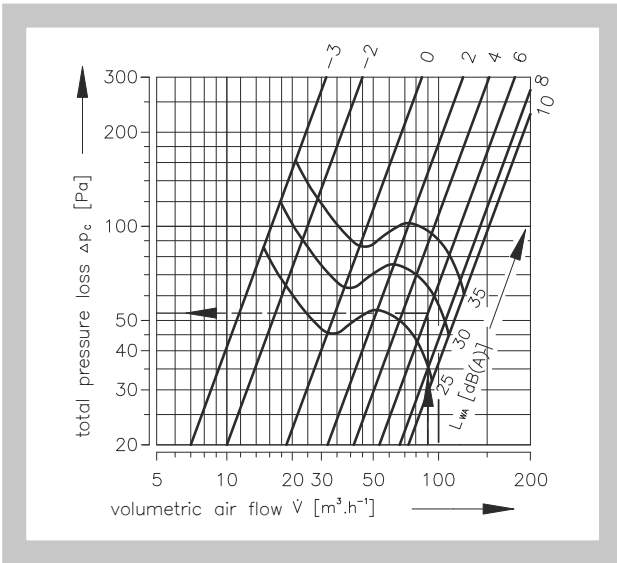

Diagram 3 CFDM-V - TVPM 125

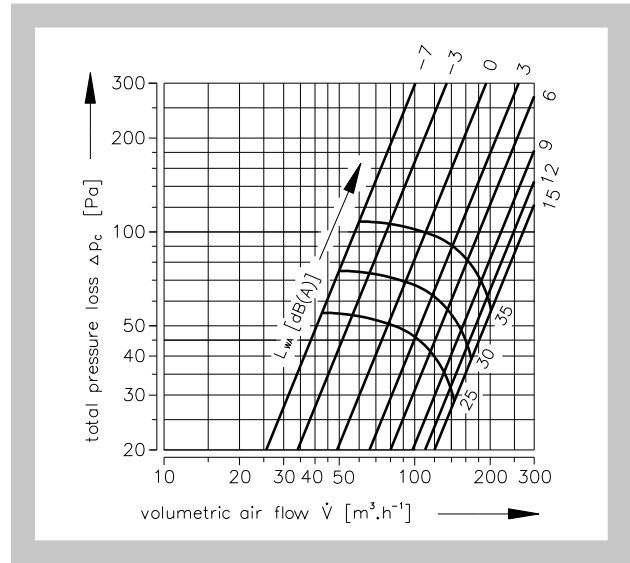

Diagram 4 CFDM-V - TVPM 160

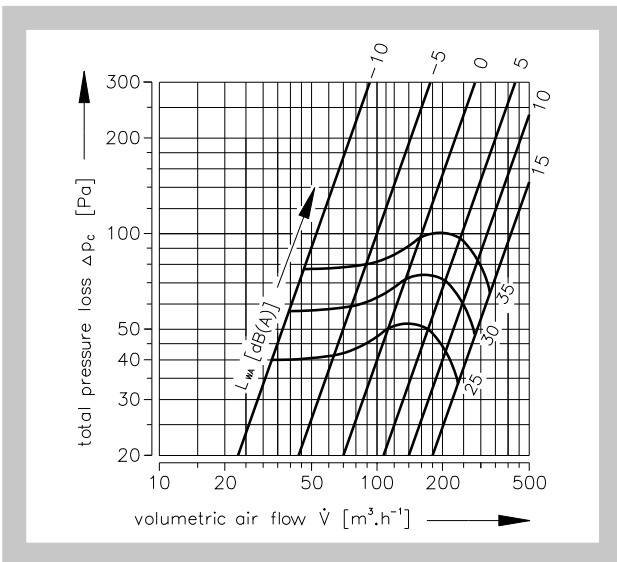
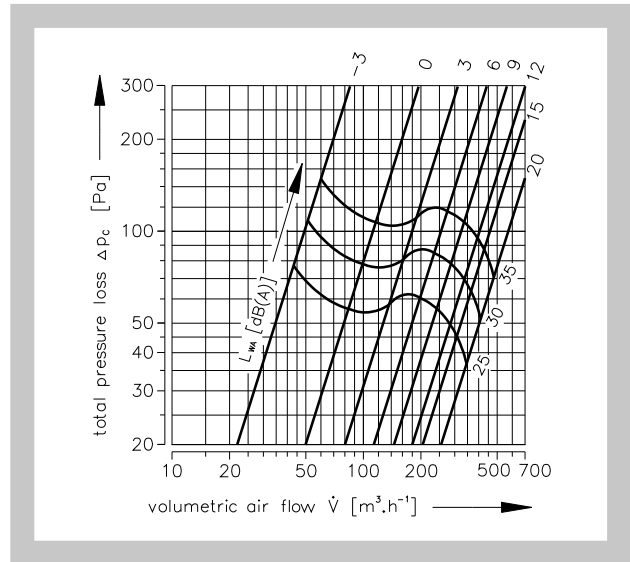

Diagram 5 CFDM-V - TVPM 200



Example

**Given data:** Damper with valve TVPM 100  
 $\dot{V} = 80 \text{ m}^3 \cdot \text{h}^{-1}$   
 $s = 8 \text{ mm}$

**Diagram 1:**  $L_{WA} = 28 \text{ dB(A)}$   
 $\Delta p_c = 43 \text{ Pa}$

8.2.2. Damper with valve for air outlet TVOM

Diagram 6 CFDM-V - TVOM 100

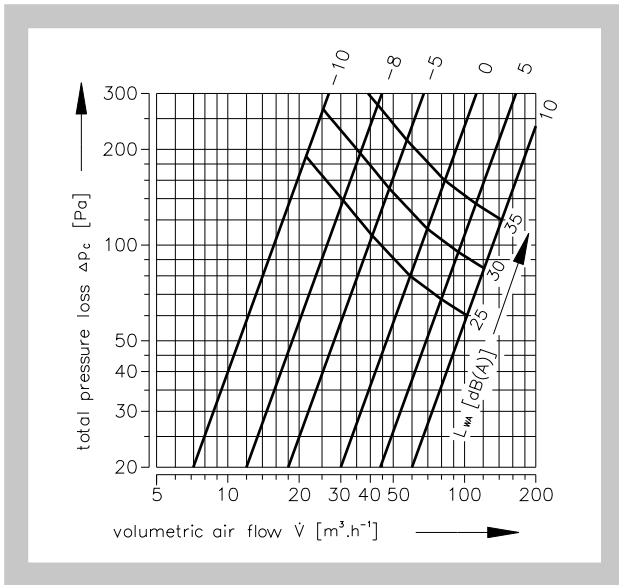

Diagram 7 CFDM-V - TVOM 125

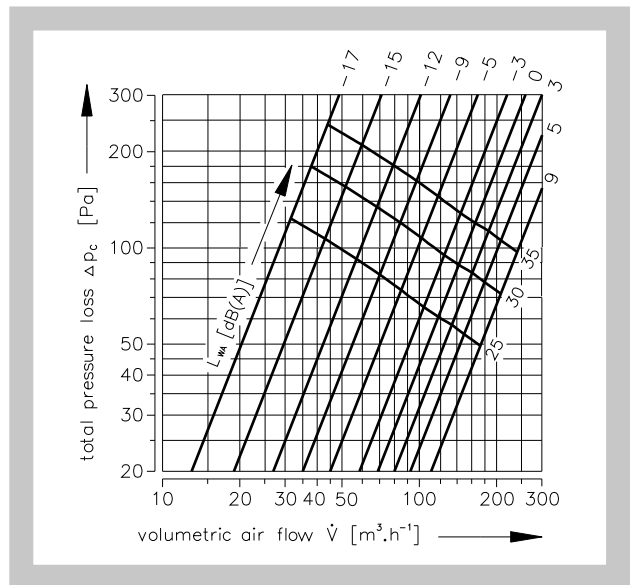

Diagram 8 CFDM-V - TVOM 160

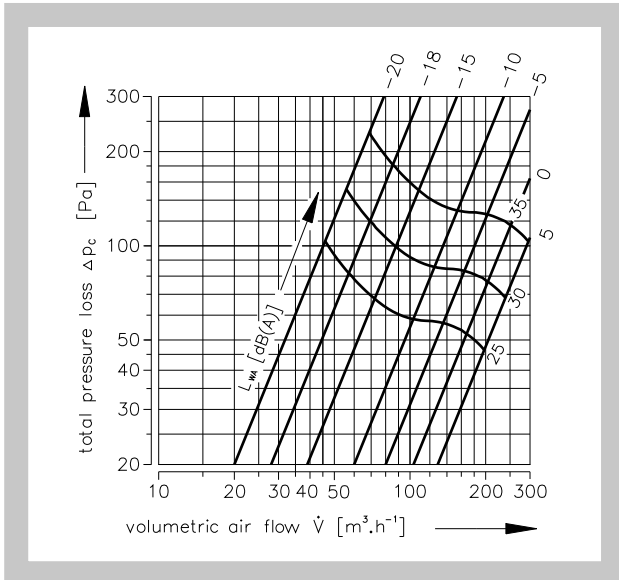
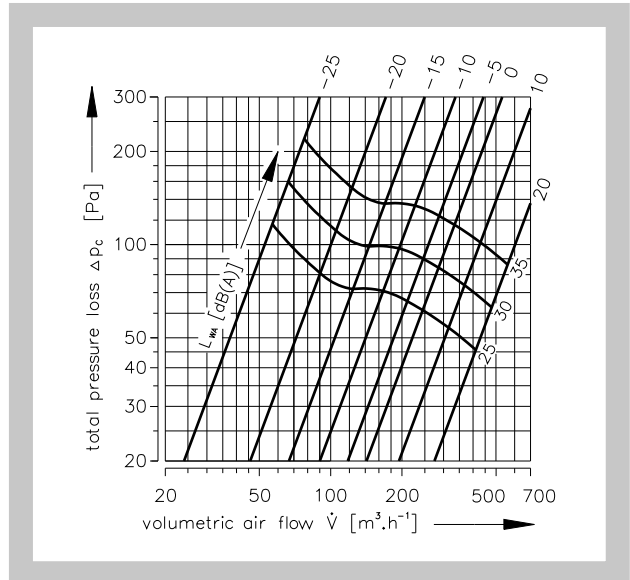

Diagram 9 CFDM-V - TVOM 200



## IV. MATERIAL, FINISHING

### 9. Material

- 9.1. Damper casing are supplied in the design made of galvanized sheet without any other surface finishing.  
Damper blades are made of fire resistant asbestos free boards made of mineral fibres.  
Damper controls are made of stainless steel with no other surface finish.  
Springs are made of stainless steel.  
Thermal protective fuses are made of sheet brass, thickness = 0,5 mm.  
Fasteners are galvanized.
- 9.2. According to the customer's requirements damper casing can be finished by color acc. RAL.
- 9.3. CFDM and CFDM-V are not manufactured in stainless steel.

## V. INSPECTION, TESTING

### 10. Inspection, testing

- 10.1. The appliance is constructed and preset by the manufacturer, its operation is dependent on proper installation and adjustment.

## VI. TRANSPORTATION AND STORAGE

### 11. Logistic terms

- 11.1. Dampers are transported by box freight vehicles without direct weather impact, there must not occur any sharp shocks and ambient temperature must not exceed +40°C. Dampers must be protected against mechanic damages when transported and manipulated. During transportation, the damper blade must be in the "CLOSED" position.
- 11.2. Dampers are stored indoor in environment without any aggressive vapours, gases or dust. Indoor temperature must be in the range from -5°C to +40°C and maximum relative humidity 80% (avoid condensation on the damper body). Dampers must be protected against mechanic damages when transported and manipulated.

## VII. ASSEMBLY, ATTENDANCE, MAINTENANCE AND REVISIONS

### 12. Assembly

- 12.1. All effective safety standards and directives must be observed during fire damper assembly.
- 12.2. To ensure reliable fire damper function it is necessary to avoid blocking the closing mechanism and contact surfaces with collected dust, fibre and sticky materials and solvents.

### 13. Entry into service and revisions

- 13.1. Before entering the dampers into operation after their assembly and by sequential checks, the following checks must be carried out.  
Visual inspection of proper damper integration, inside damper area, damper blade, contact surfaces and silicon sealing.
- 13.2. It is recommended to provide periodical checks, maintenance and service actions on Fire Equipment by Authorized persons schooled by Producer.

VIII. DATA OF THE PRODUCT

14. Data label

14.1. Data label is placed on the casing of fire damper.

Fig. 24 Data label CFDM





 MANDÍK, a.s. Dobříšská 550 267 24 Hostomice Czech Republic		<b>CFDM</b> Požární klapka / Fire damper / Brandschutzklappe / Clapet coupe-feu	
Klasifikace / Classification / Feuerwiderstand / Classification		EI90 (ve, ho-i↔o)S	
Certifikace / Certificate / Zulassungs-Nr. / Certifikat		1391-CPR-2018/0129	16
Rozměr / Size / Grösse / Taille		200	EN 15650:2010
Výr. číslo / Serial number / Fert. Nr. / Numéro de serie		SAMPLE	TPM 118/16
Provedení / Design / Ausführung / Conception		.01	<b>EIS 90</b>  <small>1391</small>
Hmotnost / Weight / Gewicht / Poids		0,5	

Fig. 25 Data label CFDM-V

 MANDÍK, a.s. Dobříšská 550 267 24 Hostomice Czech Republic		<b>CFDM-V</b> Požární klapka / Fire damper / Brandschutzklappe / Clapet coupe-feu	
Klasifikace / Classification / Feuerwiderstand / Classification		EI90 (ve, ho-i↔o)S	
Certifikace / Certificate / Zulassungs-Nr. / Certifikat		1391-CPR-2018/0129	16
Rozměr / Size / Grösse / Taille		200	EN 15650:2010
Výr. číslo / Serial number / Fert. Nr. / Numéro de serie		SAMPLE	TPM 118/16
Provedení / Design / Ausführung / Conception		.01/TVOM	<b>EIS 90</b>  <small>1391</small>
Hmotnost / Weight / Gewicht / Poids		1,34	

15. Quick review

Tab. 15.1.1. Quick review

Damper	CFDM / CFDM-V			
Size				ø 100 - 200
Fire separating construction	Wall/Ceiling	Installation	Fire resistance	Fig.
	Min. thickness [mm]			
Solid wall construction	100	Mortar or gypsum	EIS 120 EIS 90 EIS 60	14
	100	Mineral wool boards with fire resistant coating	EIS 90 EIS 60	15
	100	Mineral stone wool with fire stop coating and cement lime plate	EIS 120 EIS 90 EIS 60	16
Gypsum wall construction	100	Mortar or gypsum	EIS 120 EIS 90 EIS 60	17
	100	Mineral wool boards with fire resistant coating	EIS 90 EIS 60	18
	100	Mineral stone wool with fire stop coating and cement lime plate	EIS 120 EIS 90 EIS 60	19
Solid ceiling construction	110 - Concrete 125 - Aerated concrete	Mortar or gypsum	EIS 90 EIS 60	20
		Mineral wool boards with fire resistant coating	EIS 90 EIS 60	21

**IX. ORDERING INFORMATION**

**16. Ordering key**

**16.1. Fire dampers CFDM**

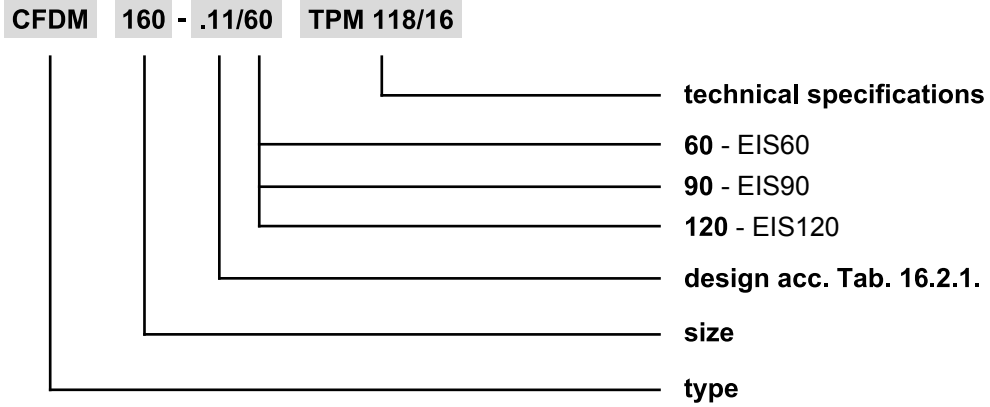

**16.2. Fire dampers CFDM-V**

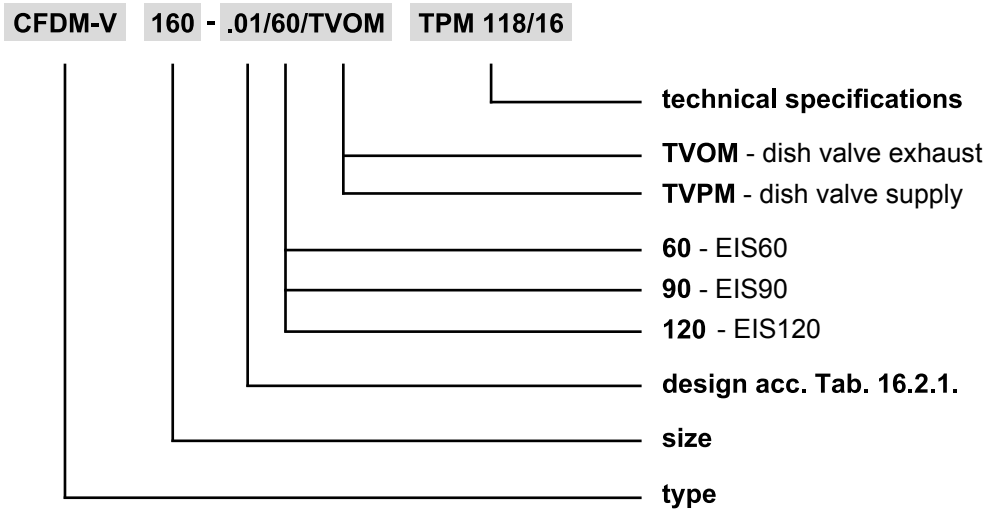

Tab. 16.2.1. Dampers design CFDM / CFDM-V

Dampers design	Additional digit
Thermal with inner mechanical control	.01
Thermal with inner mechanical control and limit switch („CLOSED“)	.11
Thermal with inner mechanical control and two limit switches („CLOSED“)	.15

MANDÍK, a.s.  
Dobříšská 550  
26724 Hostomice  
Czech Republic  
Tel.: +420 311 706 706  
E-Mail: [mandik@mandik.cz](mailto:mandik@mandik.cz)  
[www.mandik.com](http://www.mandik.com)

---

The producer reserves the right for innovations of the product. For actual product information see  
[www.mandik.com](http://www.mandik.com)