

F-C2

Cartridge Fire Damper

Handbook

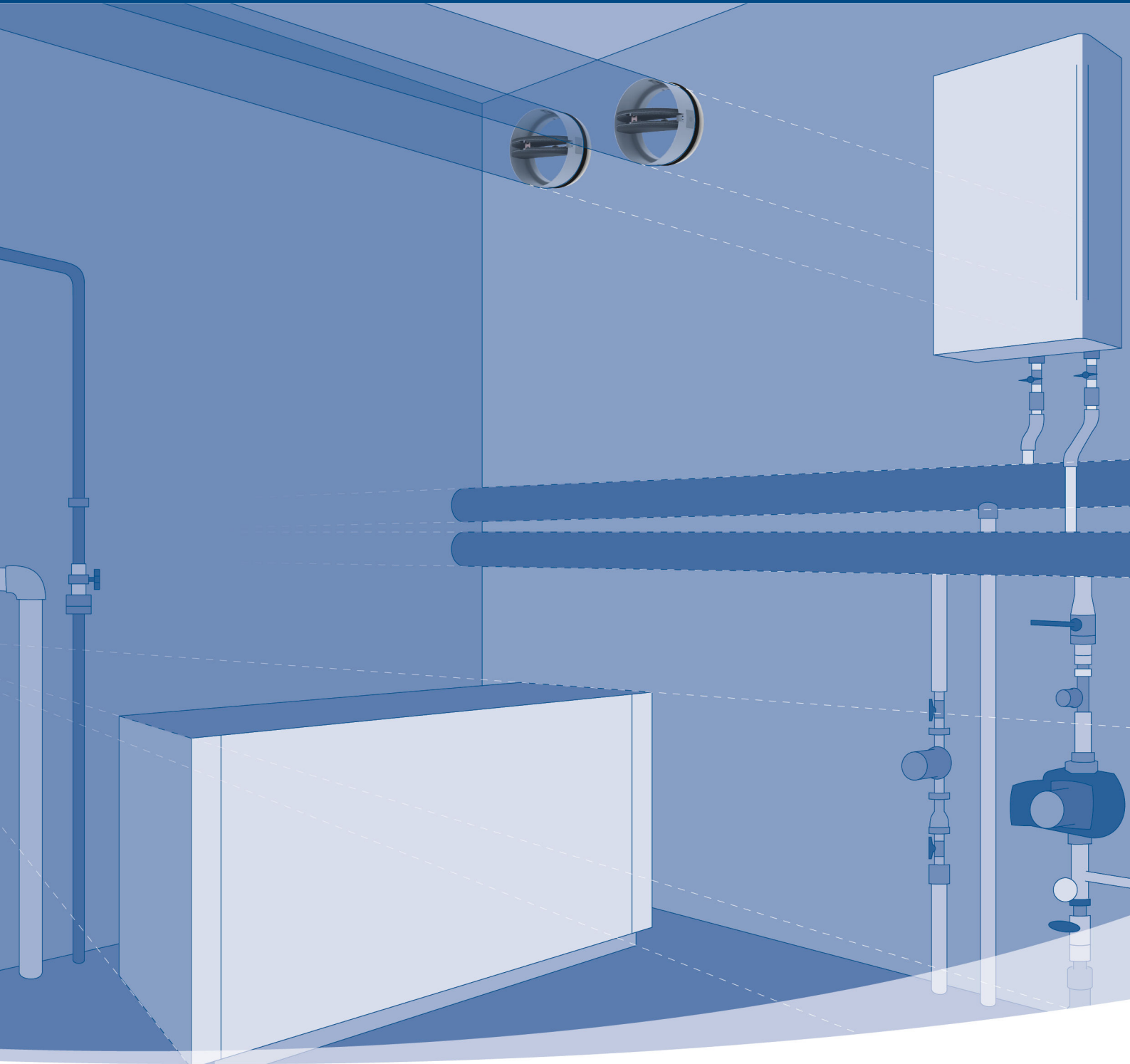

Table of Contents

<u>Overview</u>3
<u>Technical Parameters</u>5
<u>Diagrams</u>8
<u>Dimensions</u>10
<u>Ordering Code</u>11
<u>Installation</u>12
<u>Electrical Parameters</u>30
<u>Operation Manual</u>31



Description

Fire dampers represent passive fire protection, designed with the help of compartmentalization to prevent the spread of toxic gases, smoke and fire. Standard fire dampers are designed and certified in accordance with EN 15650 and tested for EIS criteria according to EN 1366-2. Fire damper together with its installation form an inseparable part of fire resistivity rating. F-C2 fire dampers are designed for the installations listed and described in their HandBook.

By default, F-C2 fire dampers are only supplied with spring loaded activation, optionally with micro switch. In case of fire, the fire damper closes automatically when the temperature of the air in the duct reaches 72°C. The F-C2 damper closes after the melting of the thermal fuse. After the closing of the damper blade, it is mechanically locked in the closed position and can only be opened manually, which requires access of the maintenance staff into the duct. To improve the accessibility for inspection of the fire damper a flexible duct coupling can be used.

Highlights

- Performance up to 2 hours
- One product fits several resistivities
- Closed state detection
- Installation with valves

Product Types

- F-C2 with size range from 80 mm up to 125 mm:
Cartridge fire damper with sheet metal blades.
- F-C2 with size range from 140 mm up to 200 mm:
Cartridge fire damper with calcium-silicate blades.

Design

F-C2 dampers have powder coated casings made from galvanized sheet metal. Blades from non-asbestos insulants and an intumescent seal, that expands in a fire situation.

Activation Types

• H0

Fire damper with a spring loaded blades with release by a thermal fuse link set to 72 °C.

• H1

Fire damper with a spring loaded blades with release by a thermal fuse link set to 72 °C + closed indication with an AC/DC 24 V contact switch on one blade.

Material Composition

The product contains galvanized sheet metal, graphite fire-proof laminate, polyurethane foam. These are processed in accordance with local regulations. The product contains no hazardous substances, except for the solder in the thermofuse, which contains a milligram of lead. Calcium silicate board is used in sizes greater than 125 mm.

List of installation Accessories

- CBR-C2: Set of 4 cover boards mandatory for dry installation of F-C2
- FCR-C2: Flexible duct connection for F-C2 accessibility

Detailed information about other accessories is available in SystemairDESIGN in fire damper accessories section.

Technical Parameters

Durability test

50 cycles with no change of the required properties

Fire testing pressure

Under-pressure up to 300 Pa

Safety position

Closed - In fire scenario the damper closes via spring between blades

Airflow direction

Both directions

Allowed air velocity

Damper can still operate at max. 6 m/s. Air without any mechanical or chemical contamination

Side with fire protection

Depending on installation classification: From both sides (i <-> o)

Repeated opening

Not possible. Only manual loading of the spring is required when installing. It is not possible to load the spring after reaching activation temperature.

Activation Temperature

72 °C

Operational temperature

- Minimum: 0 °C
- Maximum: 60 °C for 72 °C thermal fuse link

Environment suitability

Protected against weather disruptions, with temperature above 0 °C, up to 95% Rha, (3K5 according to EN 60721-3-3)

Open/Closed indication

Closed indication of one blade side with micro-switch - Activation type H1

Closing/Opening time

Approximately 1 second

Inspection possibility

By accessing through accessory FCR-C2. Or after removal of valve, when installed with valve on one or both sides.

Maintenance

Not required. Dry cleaning if demanded by law in the country in which the dampers are installed.

Revisions

Determined by law in the country in which the fire dampers are installed. It is recommended to perform visual inspection at least every 12 months.

Allowed pressure

300 Pa

Tightness of the housing (EN 1751)

Damper is placed within duct, that means the tightness class is equal to duct tightness.

Transport and Storage

Dry indoor conditions with a temperature range of -20 °C to +50 °C. The damper blade is transported in closed position.

Product parts

The F-C2 packaging also includes additional product label, that must be attached to the duct next to wall where the F-C2 fire damper is installed.

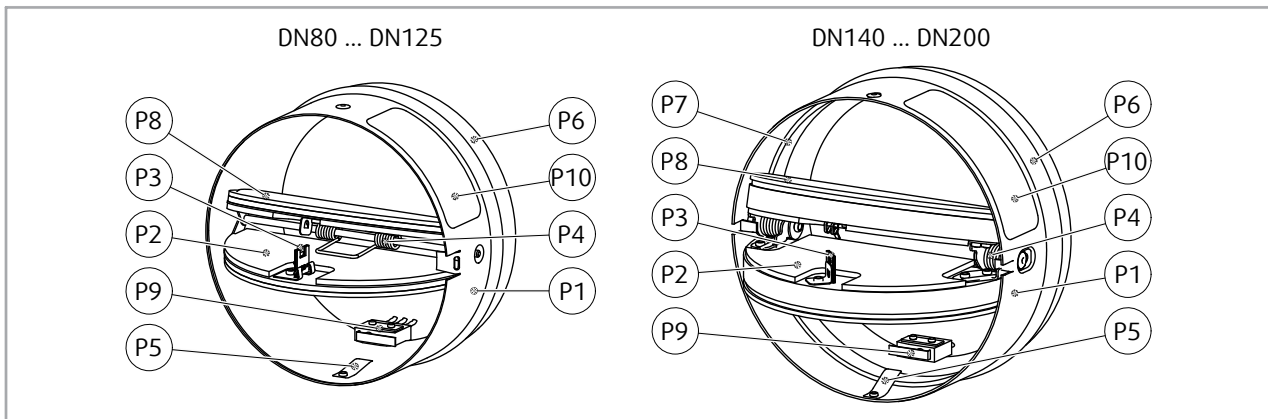

Note:

Cartridge fire damper F-C2 made with sheet-metal blades, size range from 80 mm up to 125 mm (left)

Cartridge fire damper F-C2 made with calcium silicate blades, size range from 140 mm up to 200 mm (right)

Legend:

- P1** Casing
- P2** Blades
- P3** Thermal fuse link
- P4** Blades spring
- P5** Detent spring
- P6** External peripheral sealing
- P7** Internal peripheral sealings
- P8** Blade surface foams
- P9** Microswitch 24 V AC/DC
- P10** Product label

Assessed Performance of F-C2

20 **CE** 1396

Systemair Production a.s.

Hlavná 371, 900 43 Kalinkovo, Slovakia

1396-CPR-0183, F-C2

EN 15650 : 2010

Circular fire dampers

Nominal activation conditions/sensitivity - **Pass**

- sensing element load bearing capacity
- sensing element response temperature

Response delay (response time) - **Pass**

- closure time

Operational reliability - **Pass**

- manual cycle = 50 cycles

Fire resistance:

Resistivity depending on installation method and situation

- integrity **E**
- maintenance of the cross section (under E)
- mechanical stability (under E)
- cross section (under E)
- insulation **I**
- smoke leakage **S**

Durability of response delay - **Pass**

- sensing element response temperature and load bearing capacity

Durability of operational reliability - **NPD**

- open and closing cycle

Diagrams

Accessory CBR-C2 and fire resistance class (EI60S, EI90S and EI120S) do not affect the pressure drop and A-weighted total discharged sound power level.

The pressure drop and A-weighted total discharged sound power level depend on the nominal diameter of the F-C2 and air flow volume at different duct pressures.

F-C2-...-H0

Pressure drop & A-weighted sound power level in dB(A)

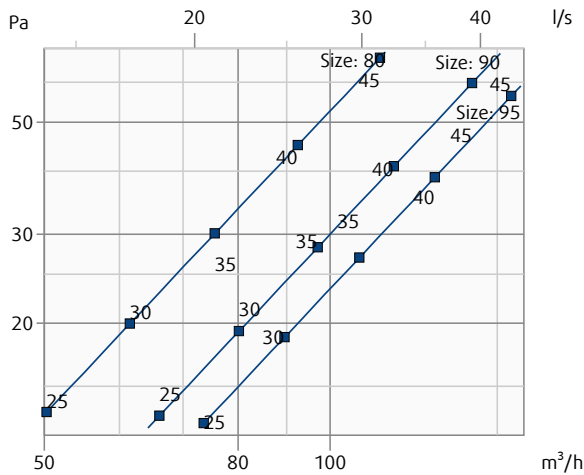

F-C2-...-H1

Pressure drop & A-weighted sound power level in dB(A)

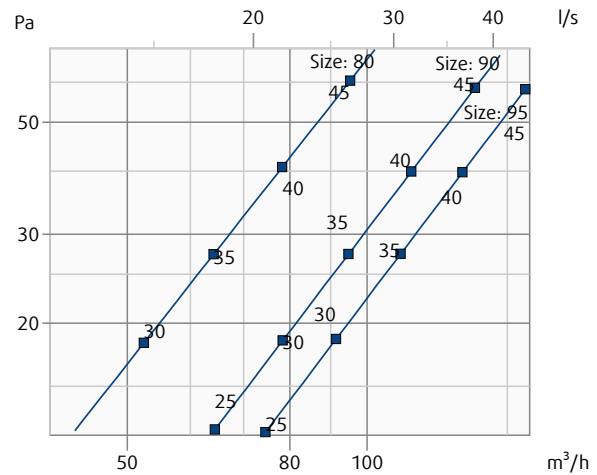

F-C2-...-H0

Pressure drop & A-weighted sound power level in dB(A)

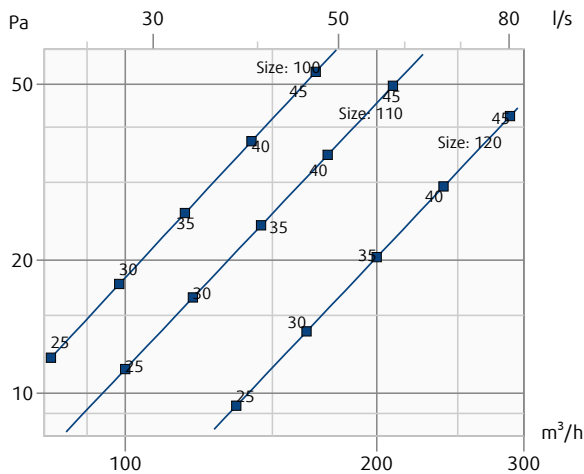

F-C2-...-H1

Pressure drop & A-weighted sound power level in dB(A)

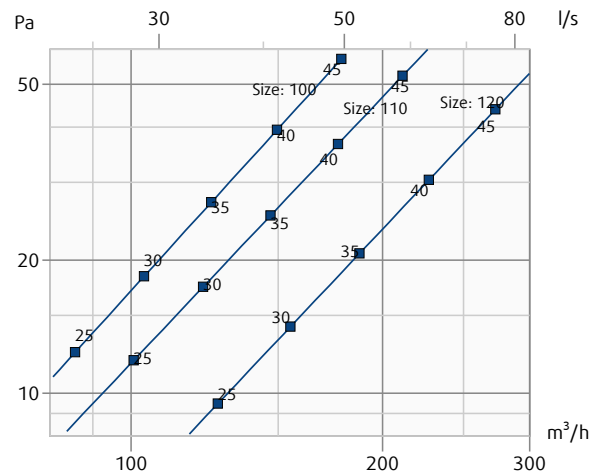

F-C2-...-H0

Pressure drop & A-weighted sound power level in dB(A)

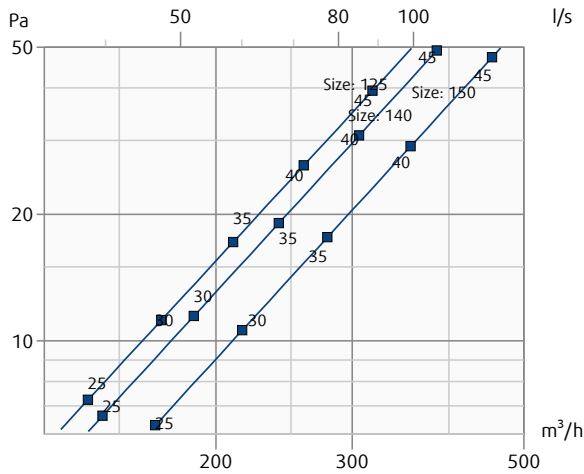

F-C2-...-H1

Pressure drop & A-weighted sound power level in dB(A)

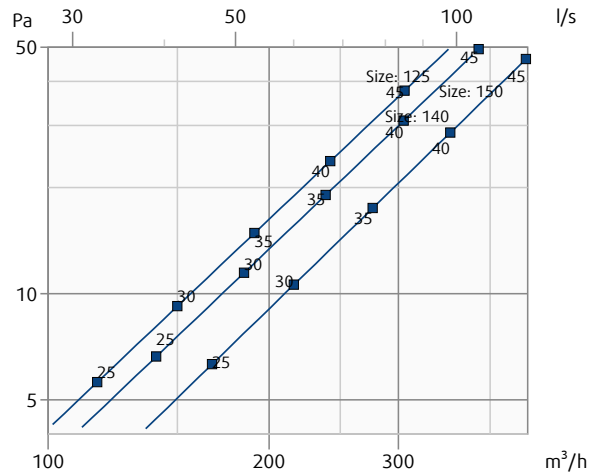

F-C2-...-H0

Pressure drop & A-weighted sound power level in dB(A)

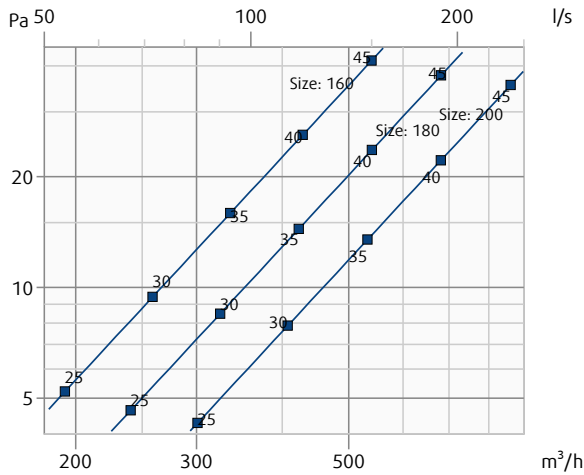

F-C2-...-H1

Pressure drop & A-weighted sound power level in dB(A)

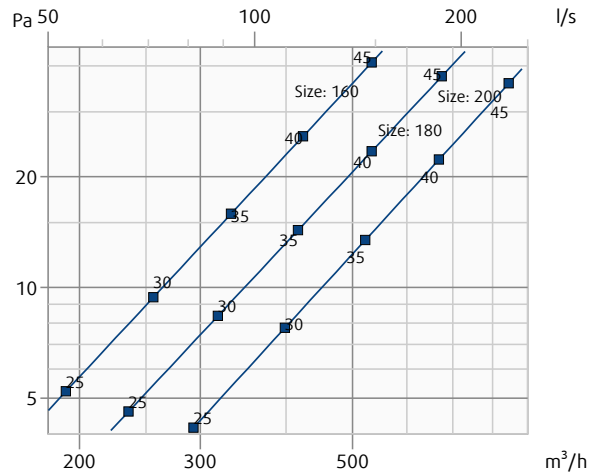

Legend:

- p_s (Pa) - Pressure drop
- q_v (m³/h), (l/s) - Air flow volume
- $\pm \Delta$ (%) - Deviation from measured value
- L_{wa} (dB(A)) - A-weighted total sound power level
- v (m/s) - Air face velocity

Dimensions & Weights

Dimensions

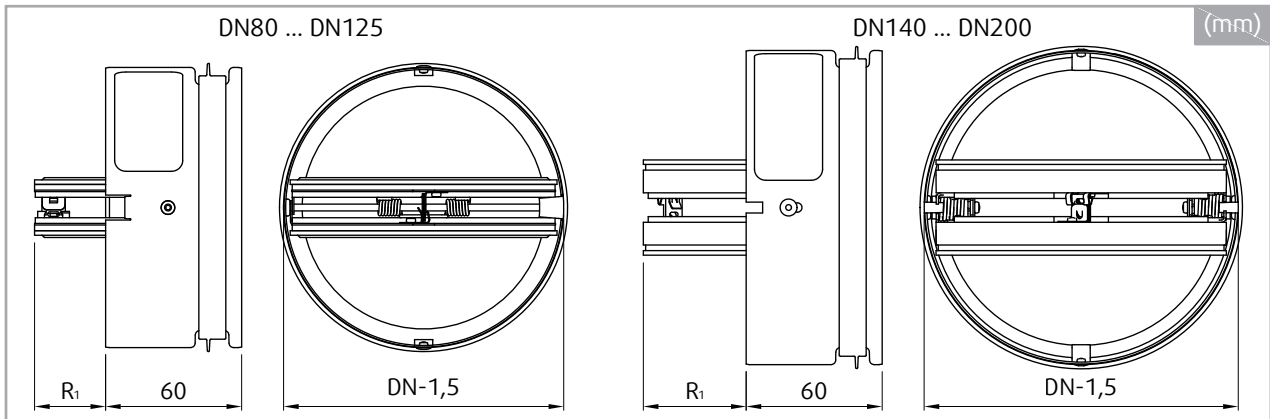

Overhangs

R_1 (mm)	DN (mm)											
	80	90	95	100	110	120	125	140	150	160	180	200
	8,8	13,8	16,3	18,8	23,8	28,8	31,3	47,0	52,0	57,0	67,0	77,0

Weights

m (kg)	DN (mm)											
	80	90	95	100	110	120	125	140	150	160	180	200
	0,20	0,23	0,25	0,26	0,30	0,34	0,36	0,50	0,60	0,60	0,70	0,90

Free area

A_v (m ²)	DN (mm)											
	80	90	95	100	110	120	125	140	150	160	180	200
	0,003	0,004	0,005	0,006	0,007	0,009	0,010	0,010	0,012	0,014	0,018	0,023

Ordering code

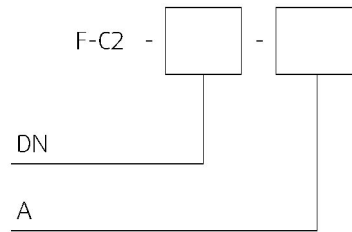

DN

Dimension, \varnothing DN:

80, 90, 95, 100, 110, 120, 125, 140, 160, 180, 200 mm

A - Type of Activation (H0 up to H1)

H0 (Spring loaded blades, release by a thermal fuse link set to 72 °C., no switches)

H1 (Spring loaded blades, release by a thermal fuse link set to 72 °C., closed indication with one AC/DC 24 V contact switch)











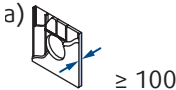
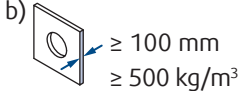

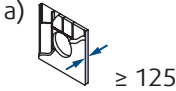
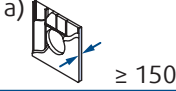
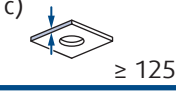

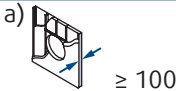
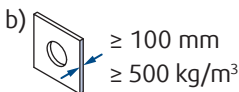
Example of the F-C2 Fire Dampers Ordering Code

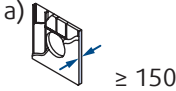
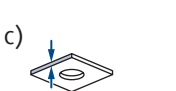
F-C2-100-H1

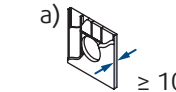
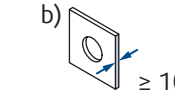
Cartridge fire damper, nominal diameter 100 mm, manually operated activation mechanism with open and closed position indication with 24 V contact microswitches.

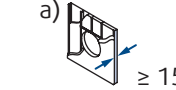
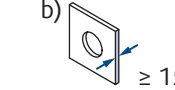
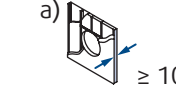
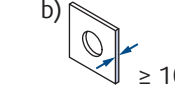
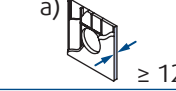
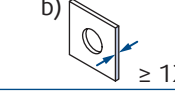
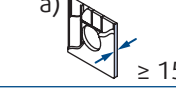
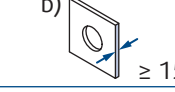
Note: The fire resistivity depends on the installation method.

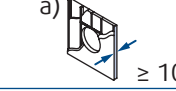
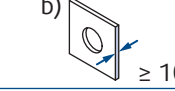
Installation Methods

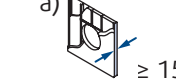
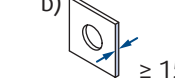
 1 Wet	F-C2 DN80 ... DN125	EI 60 ($v_e i \leftrightarrow o$) S	a) 	b) 	 360°
		EI 90 ($v_e i \leftrightarrow o$) S	a) 		
		EI 120 ($v_e i \leftrightarrow o$) S	a) 		
		EI 60 ($h_o i \leftrightarrow o$) S	c) 		
		EI 90 ($h_o i \leftrightarrow o$) S			
 1 Wet	F-C2 DN140 ... DN200	EI 60 ($v_e i \leftrightarrow o$) S	a) 	b) 	 360°
		EI 90 ($v_e i \leftrightarrow o$) S			
		EI 120 ($v_e i \leftrightarrow o$) S	a) 		
		EI 60 ($h_o i \leftrightarrow o$) S	c) 		
		EI 90 ($h_o i \leftrightarrow o$) S			
		EI 120 ($h_o i \leftrightarrow o$) S			
 2 Dry	F-C2 DN80 ... DN125	EI 60 ($v_e i \leftrightarrow o$) S	a) 	b) 	 360°
		EI 90 ($v_e i \leftrightarrow o$) S	a) 	b) 	
		EI 120 ($v_e i \leftrightarrow o$) S			
	F-C2 DN140 ... DN200	EI 60 ($v_e - i \leftrightarrow o$) S	a) 	b) 	
		EI 90 ($v_e - i \leftrightarrow o$) S	a) 	b) 	
		EI 120 ($v_e i \leftrightarrow o$) S	a) 	b) 	
 3 Soft	F-C2 DN80 ... DN125	EI 60 ($v_e i \leftrightarrow o$) S	a) 	b) 	 360°
		EI 90 ($v_e i \leftrightarrow o$) S			
		EI 120 ($v_e i \leftrightarrow o$) S	a) 	b) 	

Notes:

- 1. Wet** - Wet Installation, Using Plaster/Mortar/Concrete Filling
- 2. Dry** - Dry Installation, Using Mineral Wool and Coverplates
- 3. Soft** - Soft Installation, Using Mineral Wool filing
- a)** - Flexible (plasterboard) wall
- b)** - Concrete/masonry/cellular concrete (rigid) wall
- c)** - Concrete/cellular concrete (rigid) floor/ceiling
- v_e** - Vertical supporting construction (wall)
- h_o** - Horizontal supporting construction (floor/ceiling)

Installation rules

- The F-C2 fire damper is installed into the duct, in the place where the fire-proof wall is, or at the end of the duct in front of an air valve or a similar outlet.
- The duct that holds the fire damper must be supported or hung in such a way that the crossing does not carry its weight. The crossing must not support any part of the surrounding construction or wall which could cause damage and consequent damper failure.
- According to the standard EN 1366-2, the distance between ducts that hold F-C2 or between other objects that cross the supporting construction must be at least 200 mm.
- The distance between the wall/ceiling and the duct that holds F-C2 must be at least 75 mm.
- The fire damper is embedded into the fire partition construction into duct in such a way that when the damper blades are in the CLOSED position, that will be entirely situated inside the wall.
- The gap in the installation opening between the fire damper and the wall/ceiling can be increased by up to 50% of the gap area.
- The gap in the installation opening between the duct that holds F-C2 and the wall/ceiling can be decreased to the smallest amount possible that still provides sufficient space for the installation of the seal.
- All F-C2 dampers can be installed with the blade axis in a horizontal position or a vertical position.
- Lists of all permitted installation methods are provided in SystemairDESIGN or in HandBook of the F-C2.

IN ACCORDANCE WITH EN 15650, EACH FIRE DAMPER MUST BE INSTALLED ACCORDING TO THE INSTALLATION INSTRUCTIONS PROVIDED BY THE MANUFACTURER!

Installation, Maintenance & Operation

Some damper parts may have sharp edges – therefore to protect yourself from harm, please use gloves during damper installation and manipulation. In order to prevent electric shock, fire or any other damage which could result from incorrect damper usage and operation, it is important to:

1. ensure that installation is performed by a trained person.
 2. follow the written and depicted instructions provided within HandBook closely.
 3. perform damper inspection in accordance with HandBook.
 4. check the damper's functionality as per the chapter "Fire Damper Functionality Check" before you install the fire damper. This procedure prevents the installation of a damper that has been damaged during transportation or handling.
- Information about installation, maintenance and operation is available in the "HandBook_F-C2" document or more can be found at design.systemair.com.

Installation 1 - Wet

Using Plaster/Mortar/Concrete Filling

- The supporting construction opening must be prepared as shown on picture. Opening surfaces must be even and cleaned off. The flexible wall opening must be reinforced as per the standards for plasterboard walls.
- For installation purposes, make a round opening with a diameter of DN + 60 mm into the wall.
- Insert the duct inside the middle of the opening.

Applies only for Installation with Continuous Duct:

With one end of the duct not further than 500 mm from the wall surface. The damper must remain accessible for installation and inspection. Additional product label provided in the packaging must be applied on the duct on the inspection side.

Applies only for Installation into the End of a Duct Fitted with Valve:





End of the duct must be aligned with the wall/ceiling surface on the side of future valve placement. Additional label provided in the packaging must be applied in to the duct on the valve side.

- Fill in the area between the wall and the damper with plaster or mortar or concrete filling (F1).
- Let the filling harden.
- Check the damper's functionality
- Insert the open fire damper into the duct with the distance of 45 ± 10 mm from one wall edge to the damper body (side with external gasket).
- Apply the included additional product label to the duct or wall next to the damper insertion.
- Close off the duct with a flexible duct coupling FCR-C2 or Valve.

IMPORTANT: Make sure the valve, when inserted, is not protruding in the blade area of F-C2 damper.

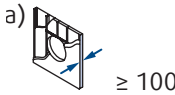
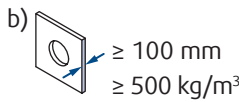
Installation Distances

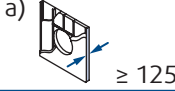
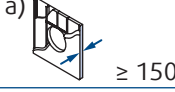
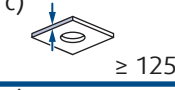
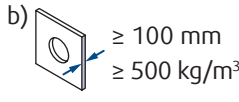
According to the standard EN 1366-2, the minimum distance from the wall or ceiling to the duct that holds F-C2 is 75 mm. For multiple crossings through a fire resistive wall the minimum distance between two ducts that hold F-C2 is 200 mm. This applies for distances between the duct that holds F-C2 and a nearby foreign object crossing the fire resistive wall.

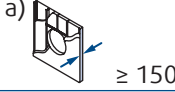
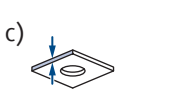
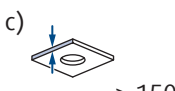
 <p>1 Wet</p>	F-C2 DN80 ... DN125	EI 60 ($v_e i \leftrightarrow o$) S	a)  ≥ 100	b)  $\geq 100 \text{ mm}$ $\geq 500 \text{ kg/m}^3$	 <p>360°</p>
		EI 90 ($v_e i \leftrightarrow o$) S	a)  ≥ 125		
		EI 120 ($v_e i \leftrightarrow o$) S	a)  ≥ 150		
		EI 60 ($h_o i \leftrightarrow o$) S	c)  ≥ 125	b)  $\geq 100 \text{ mm}$ $\geq 500 \text{ kg/m}^3$	 <p>360°</p>
		EI 90 ($h_o i \leftrightarrow o$) S			
	F-C2 DN140 ... DN200	EI 60 ($v_e i \leftrightarrow o$) S			
	EI 90 ($v_e i \leftrightarrow o$) S	a)  ≥ 100			
	EI 120 ($v_e i \leftrightarrow o$) S	a)  ≥ 150			
	EI 60 ($h_o i \leftrightarrow o$) S	c)  ≥ 150			
	EI 90 ($h_o i \leftrightarrow o$) S				
	EI 120 ($h_o i \leftrightarrow o$) S				

Notes:

1. Wet - Wet Installation, Using Plaster/Mortar/Concrete Filling

- a) - Flexible (plasterboard) wall
- b) - Concrete/masonry/cellular concrete (rigid) wall
- c) - Concrete/cellular concrete (rigid) floor/ceiling
- v_e - Vertical supporting construction (wall)
- h_o - Horizontal supporting construction (floor/ceiling)

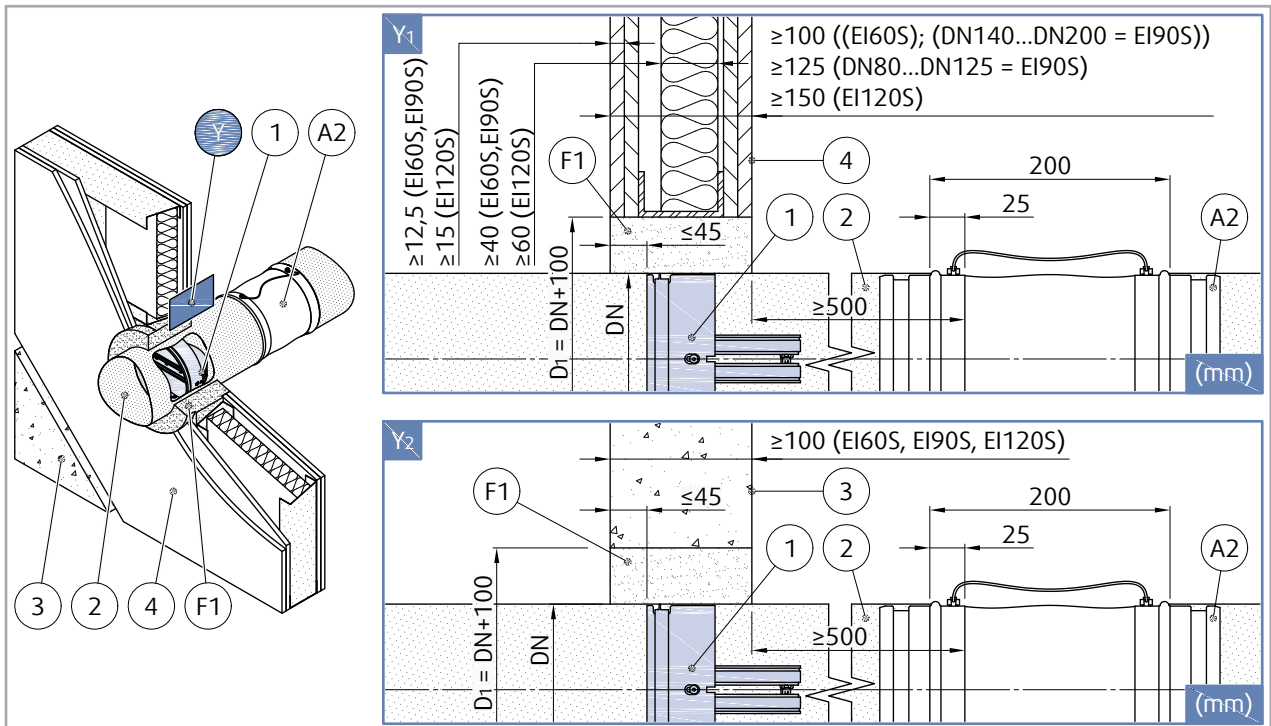

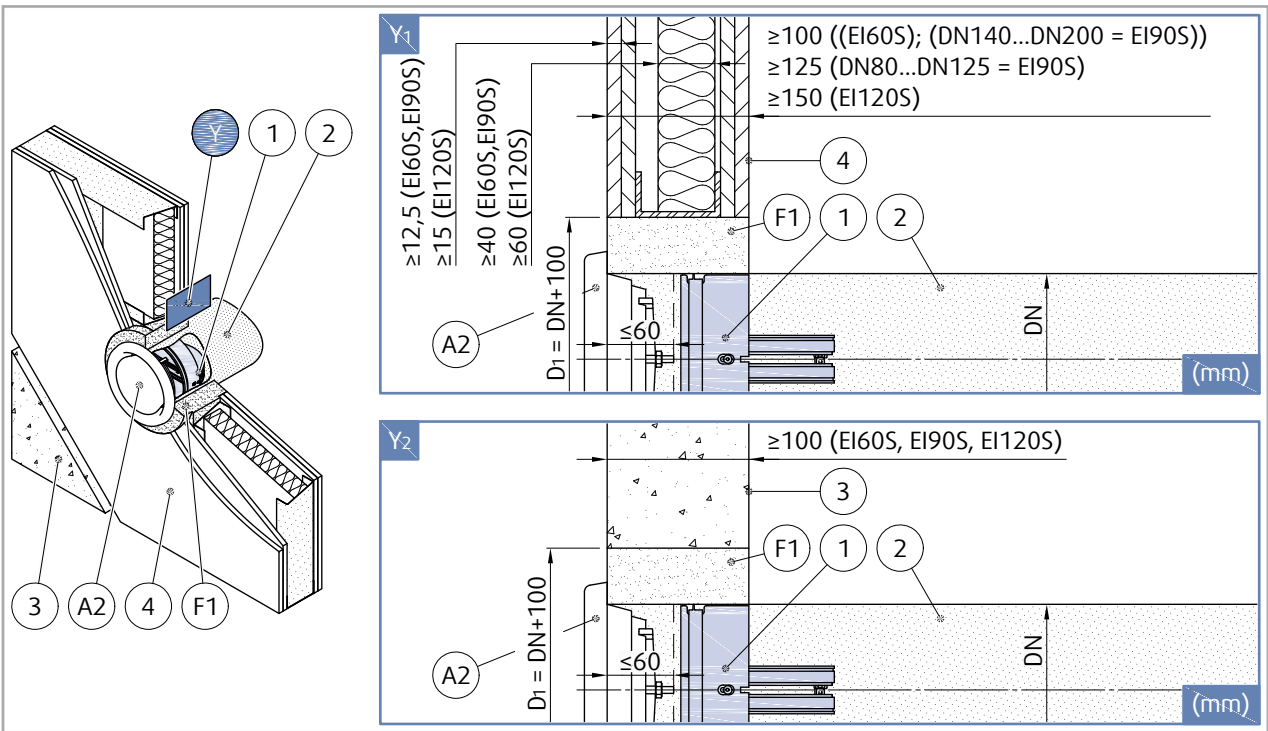
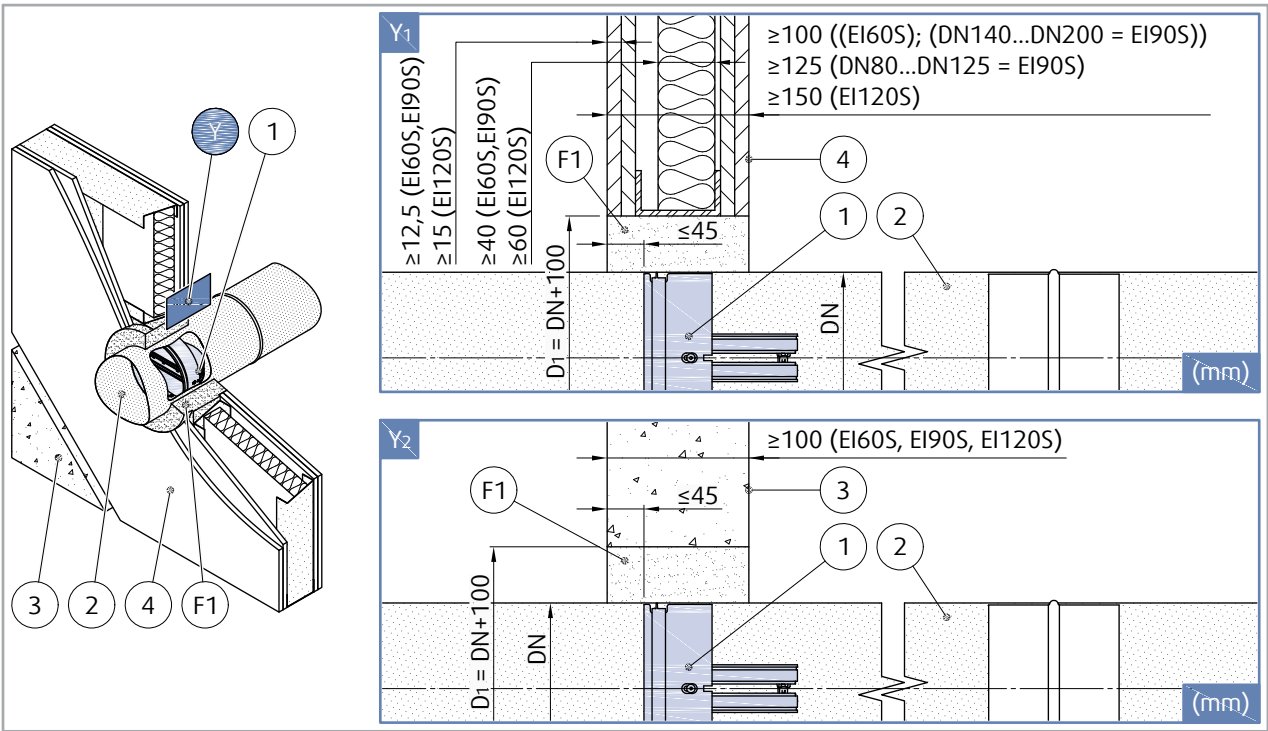

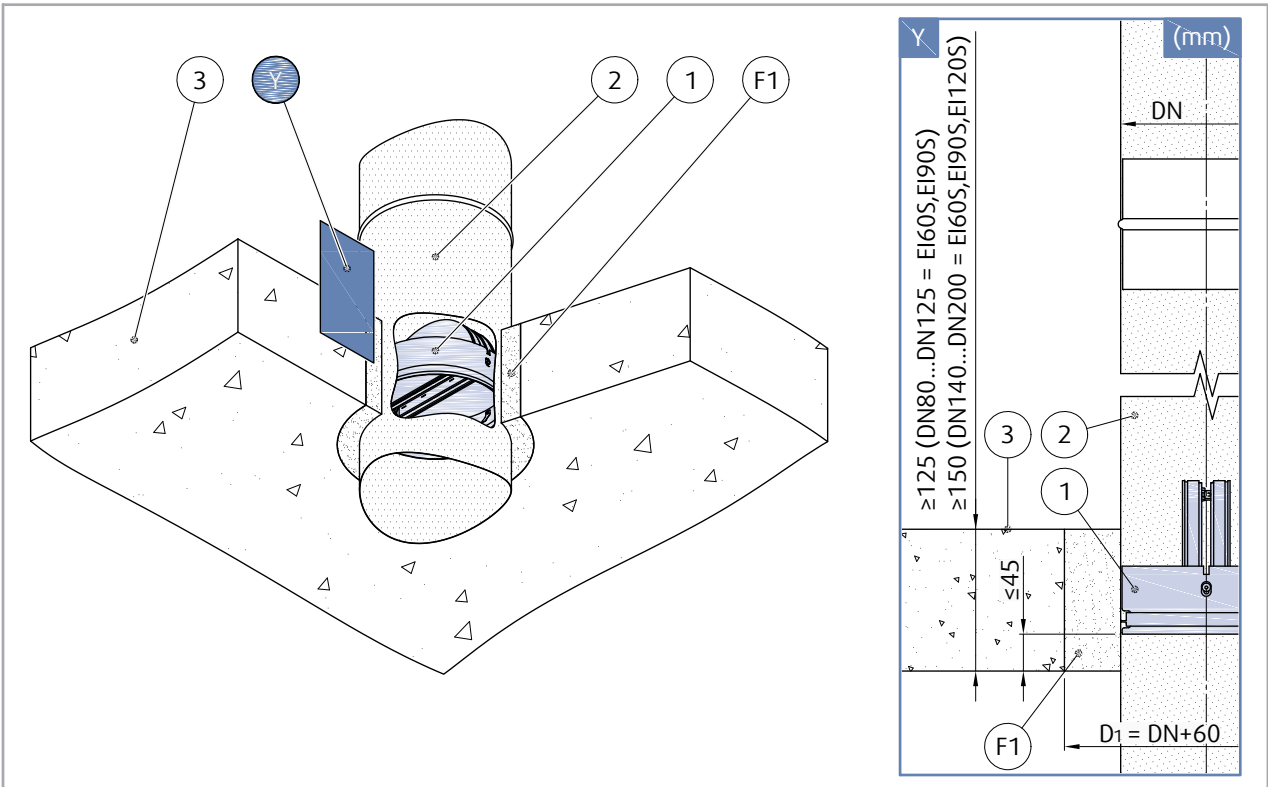
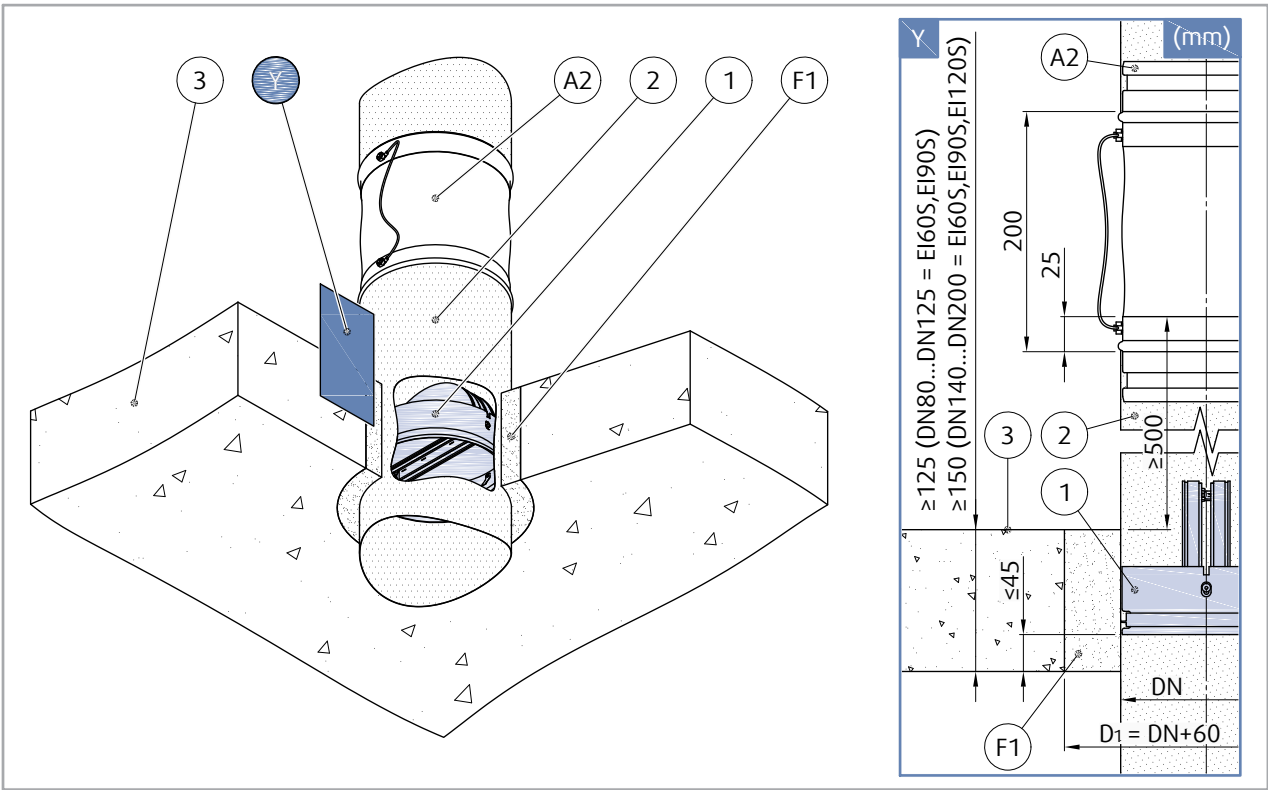

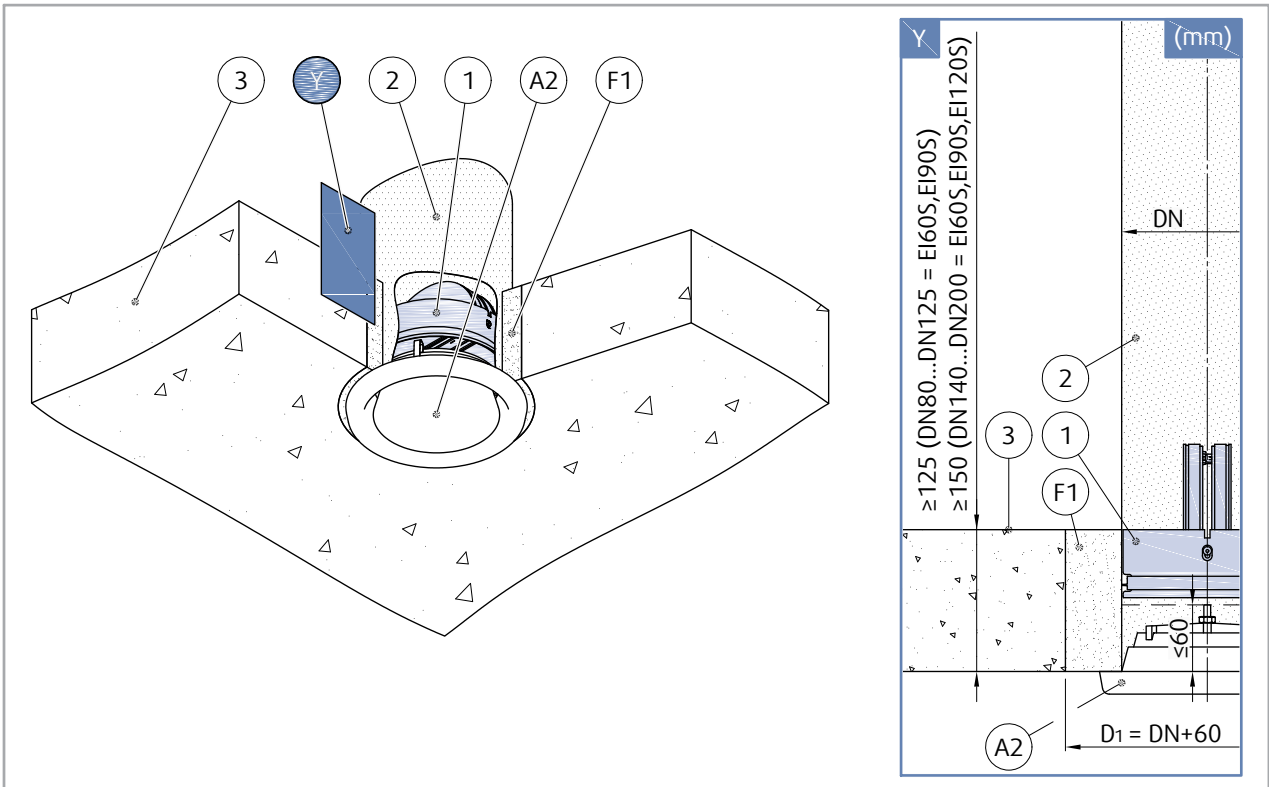

Opening and Wall and/or Ceiling Preparations

T_a (mm):
 ≥100 ((EI60S); (DN140...DN200 = EI90S))
 ≥125 (DN80...DN125 = EI90S)
 ≥150 (EI120S)

4_a (mm):
 ≥12,5 (EI60S, EI90S)
 ≥15 (EI120S)

4_c (mm):
 ≥50 ((EI60S); (DN140...DN200 = EI90S))
 ≥75 (EI90S)
 ≥90 (EI120S)

4_d:
 ≥40 mm; ≥30 kg/m³ (EI60S)
 ≥40 mm; ≥80 kg/m³ (EI90S)
 ≥60 mm; ≥85 kg/m³ (EI120S)

T_b (mm):
 ≥100 (EI60S, EI90S, EI120S)

T_c (mm):
 ≥125 (DN80...DN125 = EI60S, EI90S)
 ≥150 (DN140...DN200 = EI60S, EI90S, EI120S)

Damper Minimum Distances

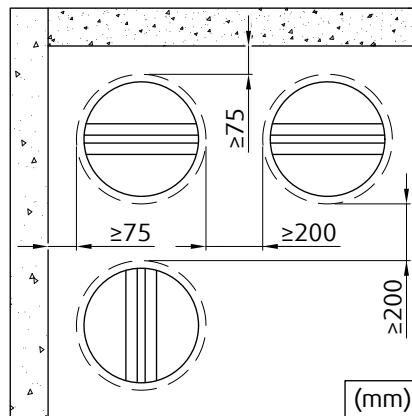

Legend

Installation 1 - Wet:

F1 Plaster/mortar/concrete filling

1 Fire damper (F-C2)

2 Connected metal ductwork

A2 Flexible duct coupling FCR-C2 / return plastic or metal valve (e.g. BALANCE-E)

3 Concrete/masonry/cellular concrete wall or ceiling

4 Flexible (plasterboard) wall

4a 2 layers of plasterboard fireproof plate type F, EN 520

4b Vertical CW – profiles

4c Horizontal CW – profiles

4d Mineral wool; thickness/cubic density see picture.

Installation 2 - Dry

Using Mineral Wool and Coverplates

- Opening surfaces must be even and cleaned off. The flexible wall opening must be reinforced as per the standards for plasterboard walls. Insert the open damper into the middle of the opening so that the damper blade is in the wall.
- For installation purposes, make a round opening with a diameter of DN + 60 mm into the wall.
- Insert the duct inside the middle of the opening.

Applies only for Installation with Continuous Duct:

With one end of the duct not further than 500 mm as the damper must remain accessible for installation and inspection. Additional label provided in the packaging must be applied on the duct on the inspection side.

Applies only for Installation into the End of a Duct Fitted with Valve:





End of the duct must be aligned with the wall/ceiling surface on the side of future valve placement. Additional label provided in the packaging must be applied in to the duct on the valve side.

- Fill in the area between the wall and the damper with mineral wool (F2) thoroughly but in such a way that will not deform the duct.
- Check the damper's functionality
- Insert the open fire damper into the duct with the distance of 45 ± 10 mm from one wall edge to the damper body (side with external gasket).
- Apply the included additional product label to the duct or wall next to the damper insertion.
- Close the gap between the damper and the mounting opening, use CBR-C2 coverplates (A1) with screws (F4) through pre-drilled holes.
- All the gaps between the coverplates, between coverplates and the wall and between coverplates and the duct need to be filled with fire resistive coating (F3).
- Close off the duct with a flexible duct coupling FCR-C2 or Valve.

IMPORTANT: Make sure the valve, when inserted, is not protruding in the blade area of F-C2 damper.

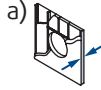
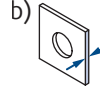
Installation Distances

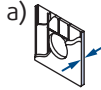
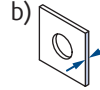
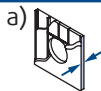
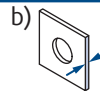
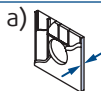
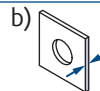
According to the standard EN 1366-2, the minimum distance from the wall or ceiling to the duct that holds F-C2 is 75 mm. For multiple crossings through a fire resistive wall the minimum distance between two ducts that hold F-C2 is 200 mm. This applies for distances between the duct that holds F-C2 and a nearby foreign object crossing the fire resistive wall.

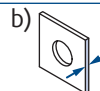
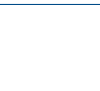
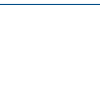
 2 Dry	F-C2 DN80 ... DN125	EI 60 (v_e i ↔ o) S	a)  ≥ 100	b)  ≥ 100	 360°
		EI 90 (v_e i ↔ o) S	a)  ≥ 150	b)  ≥ 150	
		EI 120 (v_e i ↔ o) S	a)  ≥ 100	b)  ≥ 100	
	F-C2 DN140 ... DN200	EI 60 (v_e - i ↔ o) S	a)  ≥ 125	b)  ≥ 125	
		EI 90 (v_e - i ↔ o) S	a)  ≥ 150	b)  ≥ 150	
		EI 120 (v_e i ↔ o) S	a)  ≥ 150	b)  ≥ 150	

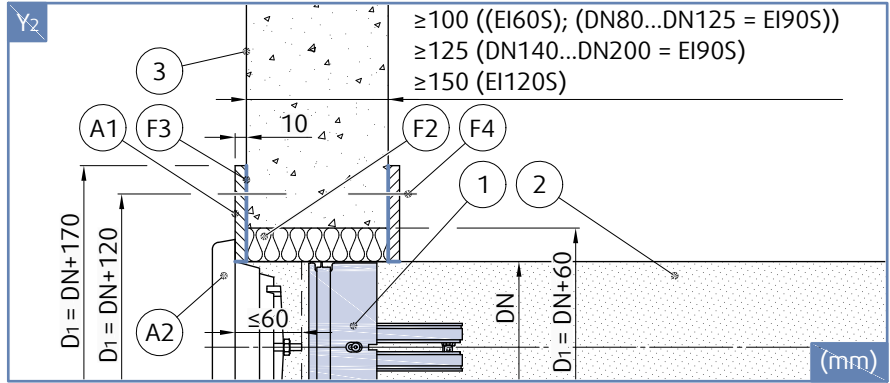
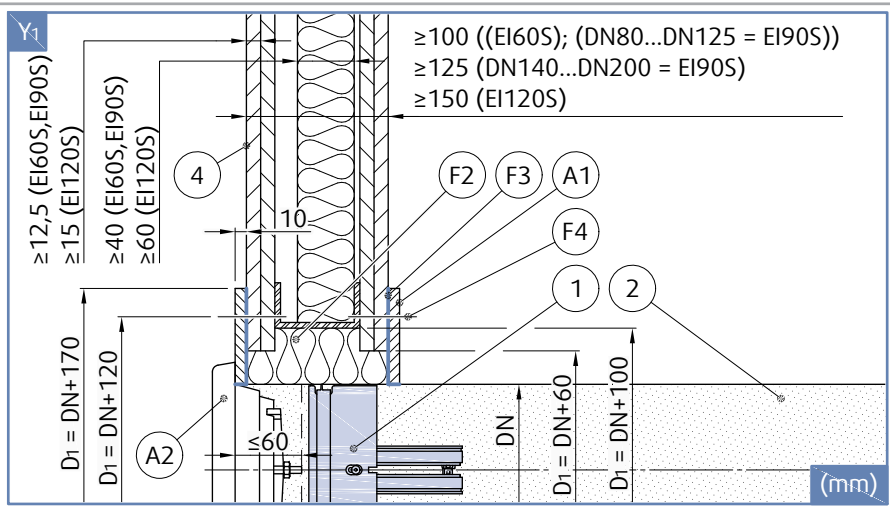
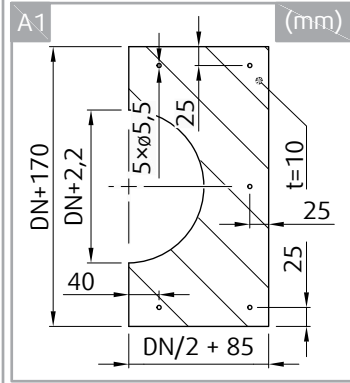
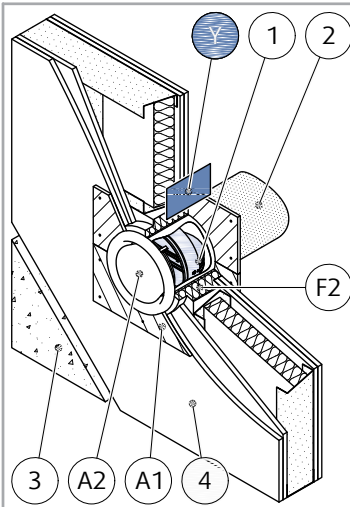
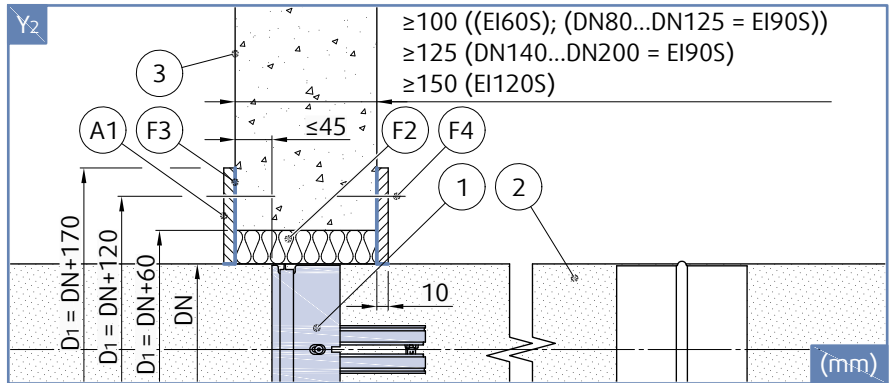
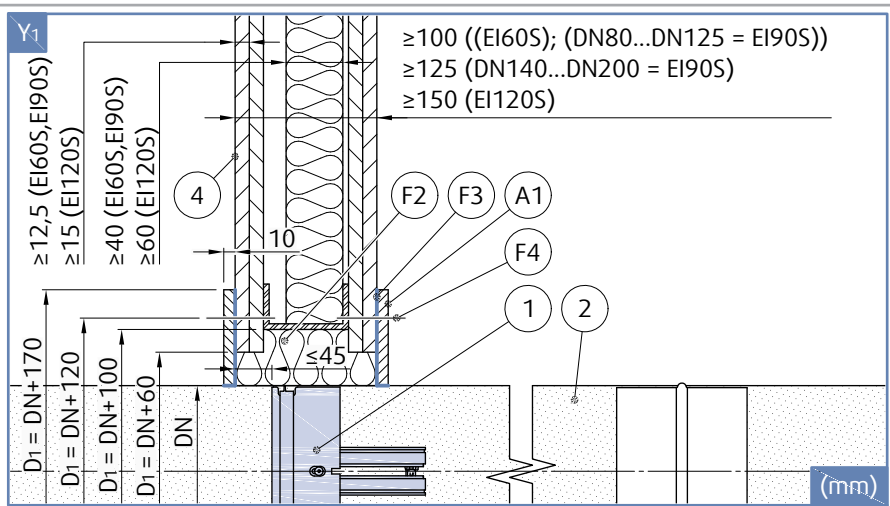
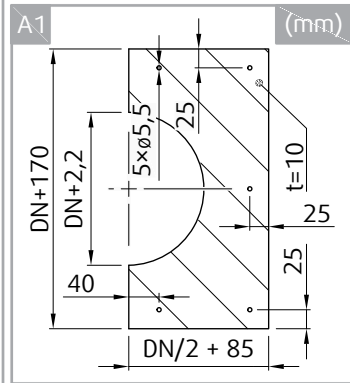
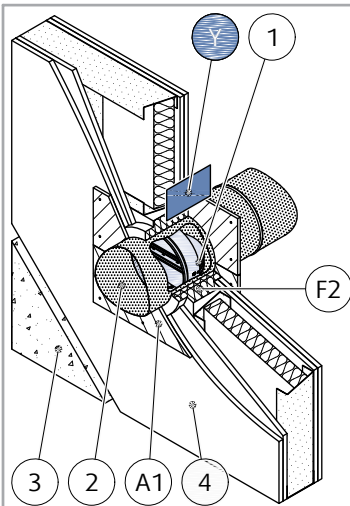

Opening and Wall and/or Ceiling Preparations

4a (mm):
 ≥12,5 (EI60S, EI90S)
 ≥15 (EI120S)

4c (mm):
 ≥50 (EI60S; DN80...DN125 = EI90S)
 ≥75 (DN140...DN200 = EI90S)
 ≥90 (EI120S)

4d:
 ≥40 mm; ≥30 kg/m³ (EI60S)
 ≥40 mm; ≥80 kg/m³ (EI90S)
 ≥60 mm; ≥85 kg/m³ (EI120S)

T_a, T_b (mm):
 ≥100 ((EI60S); (DN80...DN125 = EI90S))
 ≥125 (DN140...DN200 = EI90S)
 ≥150 (EI120S)

Damper Minimum Distances

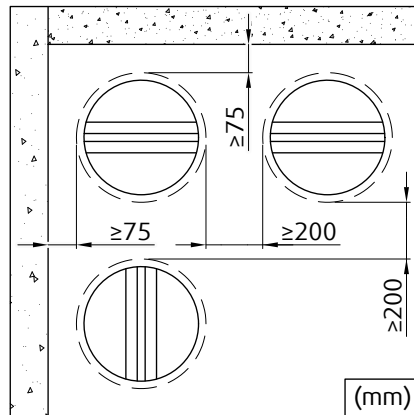

Legend

Installation 2 - Dry:

- F2** Mineral wool filling (min. 50 kg/m³)
- F3** Fire resistive coating, e.g. Promastop-CC/Promat
- F4** Screw d=5.5; e.g. DIN7981
- 1** Fire damper (F-C2)
- 2** Connected metal ductwork
- A1** Cover boards CBR-C2 (accessory) obligatory
- A2** Flexible duct coupling FCR-C2 / return plastic or metal valve (e.g. BALANCE-E)
- 3** Concrete/masonry/cellular concrete wall or ceiling
- 4** Flexible (plasterboard) wall
- 4a** 2 layers of plasterboard fireproof plate type F, EN 520
- 4b** Vertical CW – profiles
- 4c** Horizontal UW – profiles
- 4d** Mineral wool; thickness/cubic density see picture.

Installation 3 - Soft

Installation in a Soft Crossing with fire-resistive coating

With this installation we recommend using flexible connection (see accessory FCR-C2) on both sides, due thermal expansion of connected ducts during fire.

- Opening surfaces must be even and cleaned off. The flexible wall opening must be reinforced as per the standards for plasterboard walls.
- For installation purposes, make a round opening with a diameter of DN + 60 mm into the wall.
- Insert the duct inside the middle of the opening.

Applies only for Installation with Continuous Duct:

With one end of the duct not further than 500 mm from the wall surface. The damper must remain accessible for installation and inspection. Additional product label provided in the packaging must be applied on the duct on the inspection side.

Applies only for Installation into the End of a Duct Fitted with Valve:









End of the duct must be aligned with the wall/ceiling surface on the side of future valve placement. Additional label provided in the packaging must be applied in to the duct on the valve side.

- Prepare mineral wool filling (segments) with thickness of the opening height (F5).
- Apply the fire-resistive coating (F6) on the external surface of the wool filling where the future duct and hole surface will be located.
- Immediately after the fire-resistive coating is applied, place the duct piece into the wall opening together with the wool filling.
- Apply the same fire-resistive coating (F6), at least 2 mm thick and 100 mm wide, on the exposed filling and wall edges evenly from both wall sides.
- Check the damper's functionality
- Insert the open fire damper into the duct with the distance of 45 ± 10 mm from one wall edge to the damper body (side with external gasket).
- Apply the included additional product label to the duct or wall next to the damper insertion.
- Close off the duct with a flexible duct coupling FCR-C2 or Valve.

IMPORTANT: Make sure the valve, when inserted, is not protruding in the blade area of F-C2 damper.

Installation Distances

According to the standard EN 1366-2, the minimum distance from the wall or ceiling to the duct that holds F-C2 is 75 mm. For multiple crossings through a fire resistive wall the minimum distance between two ducts that hold F-C2 is 200 mm. This applies for distances between the duct that holds F-C2 and a nearby foreign object crossing the fire resistive wall.

 3 Soft	F-C2 DN80 ... DN125	EI 60 (v_e i ↔ o) S	a)  ≥ 100	b)  ≥ 100	 360°
		EI 90 (v_e i ↔ o) S	a)  ≥ 150	b)  ≥ 150	
		EI 120 (v_e i ↔ o) S	a)  ≥ 150	b)  ≥ 150	

Notes:

3. Soft - Soft Installation, Using Mineral Wool filing

a) - Flexible (plasterboard) wall

b) - Concrete/masonry/cellular concrete (rigid) wall

v_e - Vertical supporting construction (wall)

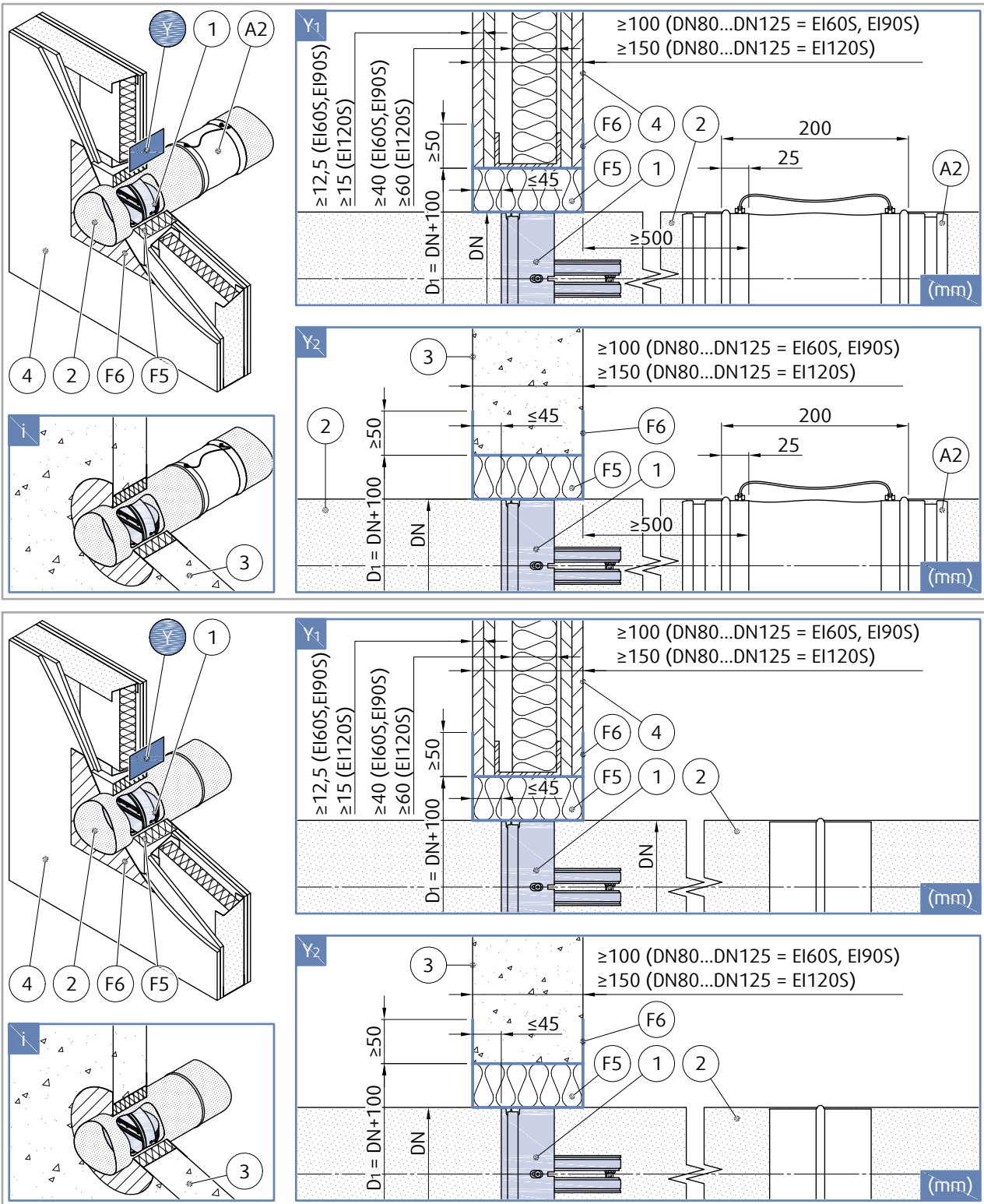

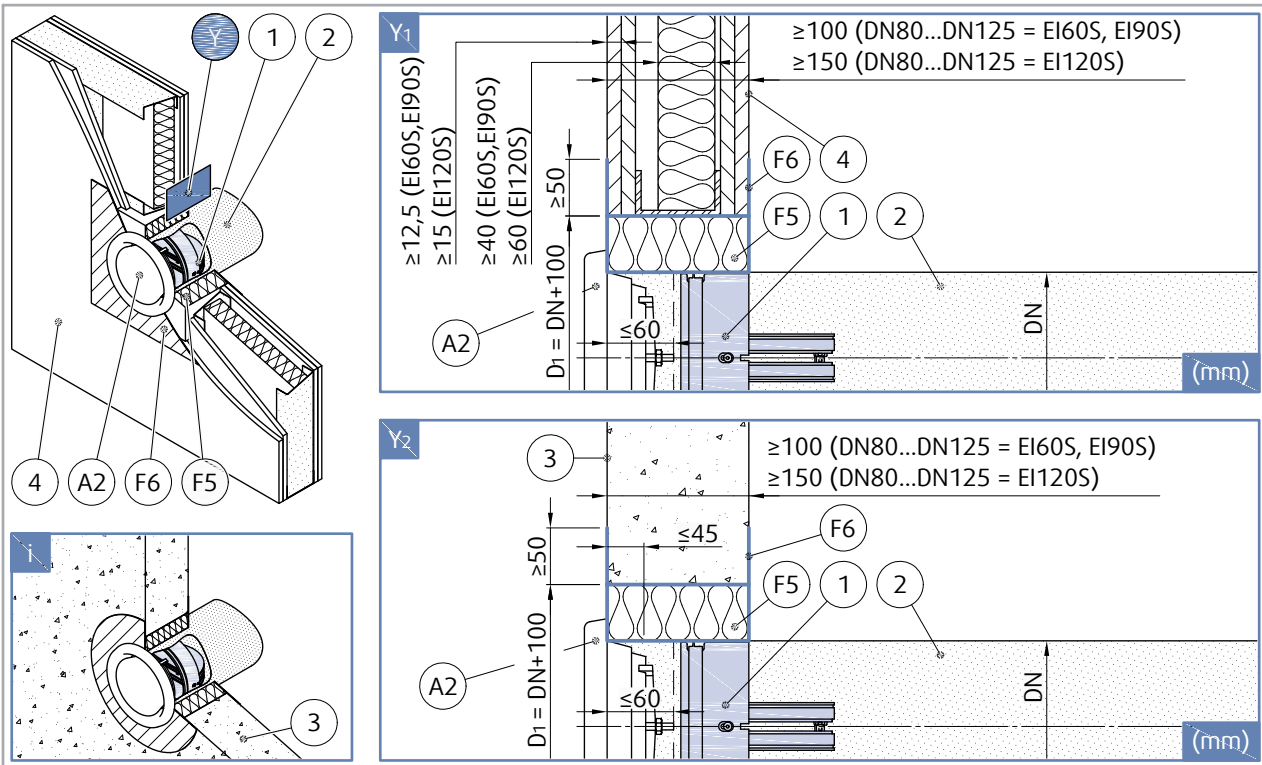

Opening and Wall and/or Ceiling Preparations

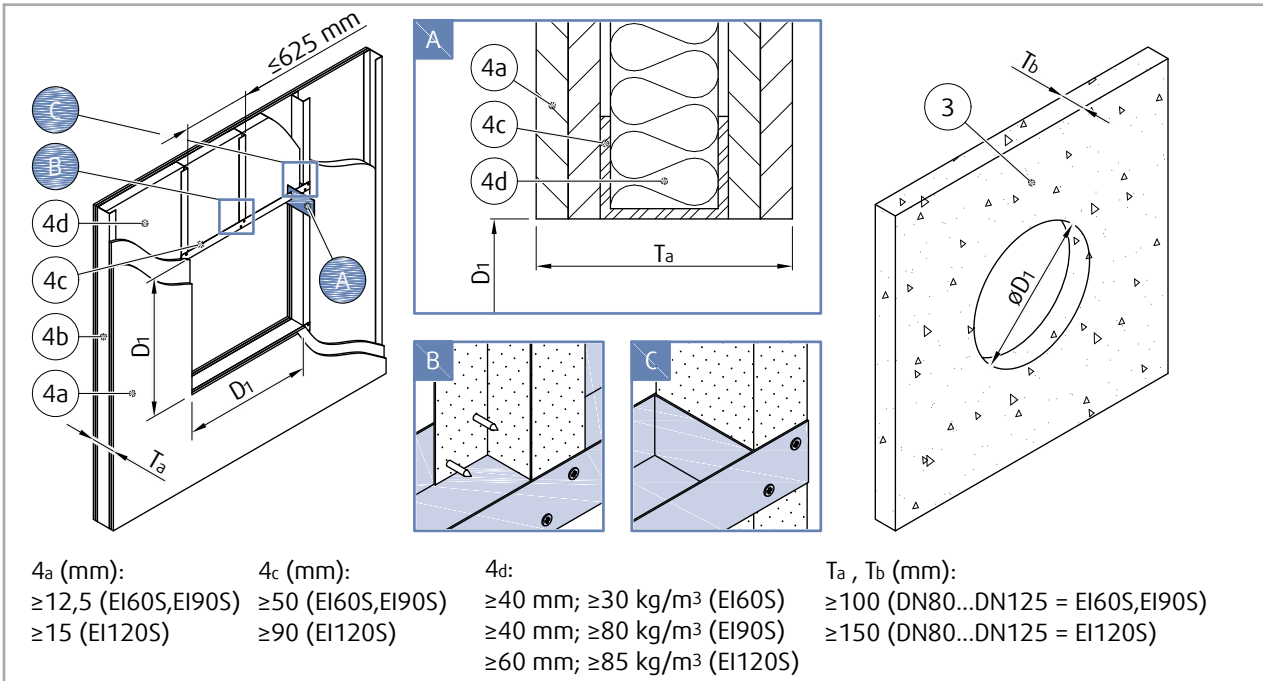

Damper Minimum Distances

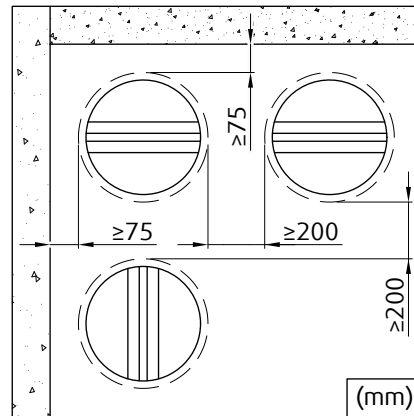

Legend

Installation 3 - Soft:

F5 Mineral wool filling (min. 100 kg/m³)

F6 Layer of fire resistive coating (Promastop-CC/Promat) at least 2 mm thick for exposed surfaces.

1 Fire damper (F-C2)

2 Connected metal ductwork

A2 Flexible duct coupling FCR-C2 / return plastic or metal valve (e.g. BALANCE-E)

3 Concrete/masonry/cellular concrete wall or ceiling

4 Flexible (plasterboard) wall

4a 2 layers of plasterboard fireproof plate type F, EN 520

4b Vertical CW – profiles

4c Horizontal UW – profiles

4d Mineral wool; thickness/cubic density see picture.

Electrical Connections

Type of activation H0

This type of activation mechanism does not have any electrical equipment.

Type of activation H1

IMPORTANT: Risk of electric shock!

Microswitch:

Power Supply: 12/24V DC Electric Parameters: 3A

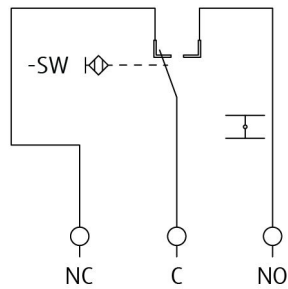

Legend

NO Blue cable colour

C Black cable colour

NC Grey cable colour

NOTES:

- Switch off the power supply before working on any electrical equipment.
- Only qualified electricians are allowed to work on the electrical system.
- Power consumption must be observed!

Operation Manual

Warning: Both sides of F-C2 blades are spring loaded in the open position and are closing very quick. To avoid injury, make sure to keep the blades movement area clear while manipulating with F-C2.

The fire damper is ready for installation when its blades are in open position. The blade position, if using a H1 version, is indicated by an end switch, which indicates when pushed the damper blades' closed position.

To open the damper follow these steps:

A Check the thermal fuse link. Thermal fuse link is inserted only in one blade and both parts of the link hold together.

B Press detent spring.

C Open the blade into a parallel position with the casing

D Press the blades together and hook the fuse link onto both blades.

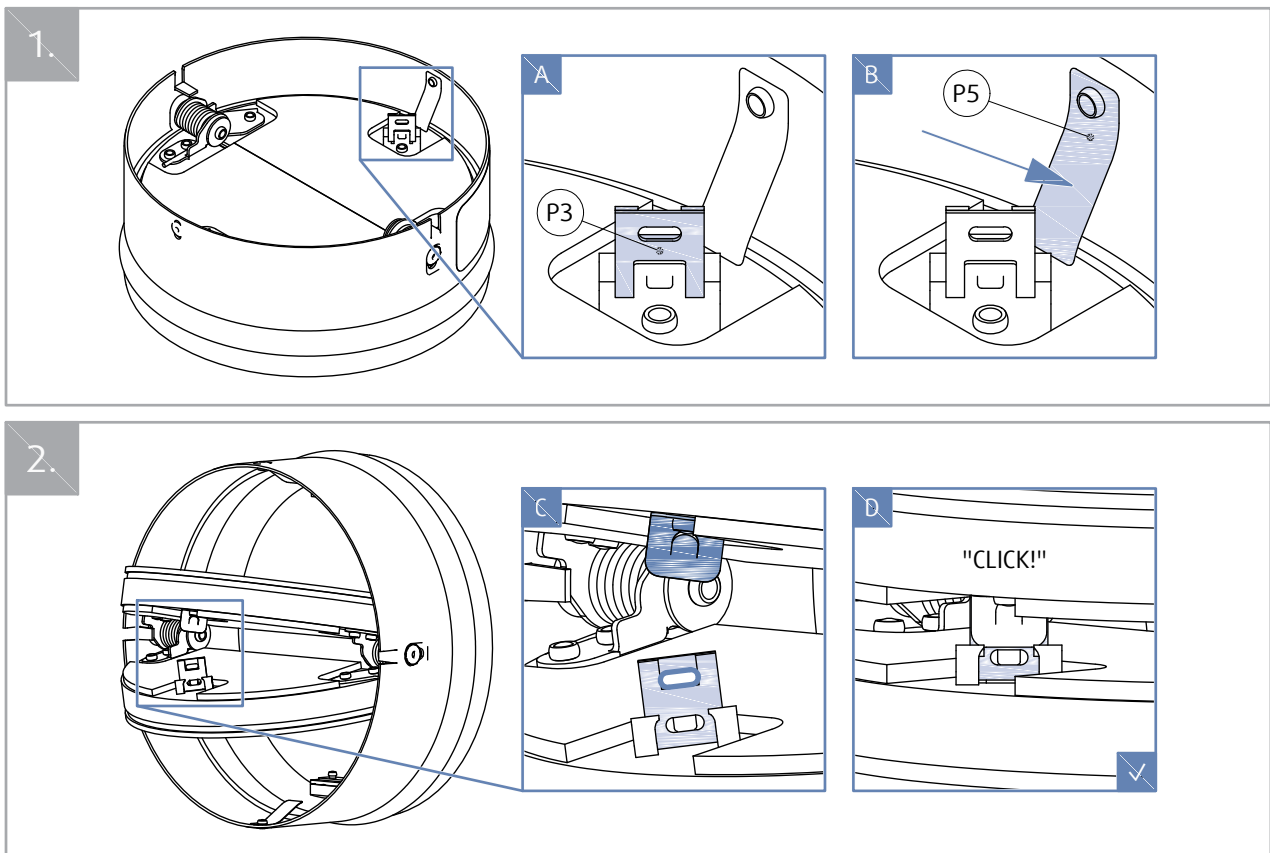

Fire Damper Functionality Check

- While performing the check, focus on the thermal fuse link's integrity and a correct position of the damper blades after their detention in the OPEN position – they should be roughly parallel to the longitudinal axis of the duct.
- Perform the damper activity check by taking off the thermal fuse link and releasing the blades to spontaneously close them – the damper blades are closed by a spring return release.
- If using the H1 version, the blade's position is indicated by a connection of the respective circuit shown in section Electrical connections
- Open the blades again and detent them in the OPEN position following instructions shown in section "Operation Manual".
- When remounting the damper into the duct it is also essential to check the flexibility of the sealing on the perimeter and in case it shows permanent deformation, it is needed to replace the seal with a new one in order to guarantee a correct fixation of the damper in the duct.

Damper Inspection

The spring mechanism keeps the dampers on stand-by mode throughout their entire operational life. Without the producer's permission, there must be no changes or modifications performed on the dampers' structure.

The operator performs regular inspections of the dampers as per established regulations and standards at least once every 12 months. The inspection needs to be performed by an employee who has been specifically trained for this purpose by the manufacturer. The current fire damper condition determined during the inspection needs to be entered into the "Operating Journal" along with the date of the inspection, the legible name, surname and signature of the employee who performed the inspection. The Operating Journal includes a copy of the employee's authorization.

If any discrepancies are discovered, these need to be entered in the Operating Journal along with a proposal for their removal. The Operating Journal can be found downloaded from design.systemair.com. Before the first installation, it needs to be inspected under the identical conditions as apply to the above mentioned 12-month inspections.

It is needed to inspect the damper's internal casing, the thermal fuse link, the sealing, the foaming substance, the damper blade's condition and its closure while it leans to a backstop in a closed position. There must be no other objects or dirt from the ventilation duct inside the damper.

NEVER INSPECT THE DAMPERS WHEN THERE IS AIR FLOWING IN THE DUCT SYSTEM!

Recommended Inspection Steps According to the EN 15 650:

- Date of inspection
- Check of the end switch's connection for damage if applicable
- Check for damper cleanliness and cleaning if needed
- Check of the blades and sealing, correction and record if needed
- Check of fire damper's safe closure – for details please see the previous section
- Check if the damper moves while being in its open and closed position, correction and record if needed
- Check of the end switch indicating the open and closed position, correction and record if needed
- Check if the damper is moved in its standard position. The F-C2 damper's position is correct when, after the closure, the blades are in between the planes forming the outside surface of the wall – the ideal position is when the blade is in the middle between these planes.

Supplement

Any deviations from the technical specifications contained in SystemairDESIGN and the terms should be discussed with the manufacturer. We reserve the right to make any changes to the product without prior notice, provided that these changes do not affect the quality of the product and the required parameters.

