

# MANDÍK<sup>®</sup>

## MULTI BLADE FIRE DAMPER

### FDML



These specifications define the line of produced sizes, main dimensions, models and scope of application of FDML multi blade fire dampers. The specifications are binding for design, manufacture, delivery, storage, assembly, operation, maintenance and serviceability checks.

**■ TABLE OF CONTENTS**

<b>■ GENERALLY</b>	<b>3</b>
Description.....	3
Design.....	4
Dimensions and weight.....	6
Electrical components, wiring diagram.....	10
Installation and placement.....	14
<b>■ TECHNICAL DATA</b>	<b>19</b>
Pressure loss.....	19
Coefficient of local pressure loss $\xi$ .....	19
<b>■ MATERIAL, FINISHING</b>	<b>20</b>
Material.....	20
<b>■ CHECKS, TESTS</b>	<b>20</b>
Checks.....	20
Tests.....	20
<b>■ PACKAGING, TRANSPORT, ACCEPTANCE, STORAGE</b>	<b>21</b>
Logistic data.....	21
Guarantee.....	21
<b>■ ASSEMBLY, OPERATION AND SERVICEABILITY CHECKS</b>	<b>21</b>
Assembly.....	21
Putting into operation and serviceability checks.....	21
Spare parts.....	21
<b>■ PRODUCT DATA</b>	<b>22</b>
Nameplate.....	22
<b>■ ORDER KEY</b>	<b>22</b>

■ **GENERALLY**

**Description**

FDML multi blade fire dampers are in motor-driven versions with servo drives and they have the following two main applications:

- They are applied as fire closures without following air condition duct with cover grids for closure of vents in fire dividing walls, constructions, elevator and other shafts, cable and other channels preventing spread of fire heat and other combustion products.
- If applied as multi blade fire damper with air condition connecting pipes from both ends (without grids) or with connecting pipe at one end (1x grid) they prevent spreading of heat and combustion products through such piping system.

If the damper is hit with fire it will automatically (or remotely as the case may be) be closed and spread of fire from one fire sector to another will be prevented. Damper blades automatically close air flow using servo check spring. The servo check spring is put into operation at activation of thermo-electric actuator by pressing reset button or with interruption of servo feeding. Once the blades have been closed the damper is sealed using silicone seal against fume penetration. At the same time damper blade is placed in a material which increases its volume by actuating higher temperature and seals the damper hermetically. Dampers are not furnished with inspection chambers. If these dampers are used as dampers for simple maintenance and revision they must be completed with connecting inspection equipment installed just behind the damper.

**Damper characteristics**

- CE certification according to EN 15650
- Tested according to EN 1366-2
- Classified according to EN 13501-3+A1
- Fire resistance EI 90 S, E 120 S
- Damper casing air leakage category B, air leakage through damper blade category 3 according to EN 1751
- Cycling tests C10000 according to EN 15650
- Corrosion resistant according to EN 15650
- ES Certificate of conformity No. 1391-CPR-2020/0130/O1
- Declaration of Performance No. PM/FDML/01/22/1
- Hygienic assessment of fire dampers - Report No. 1.6/pos/19/19b

**Failure-free functioning of dampers is ensured under the following conditions:**

- Maximum airflow velocity 12m/s.
- Maximum pressure difference on damper blade 1500 Pa.
- Even distribution of air flow in complete damper cross section area.
- Damper operating characteristics are independent on airflow direction through the damper. The damper can be installed with blade axis vertically or horizontally, temperature sensor must always be in damper upper part.
- Dampers are intended for airs without abrasive, chemical and sticky admixtures.
- Dampers are intended for environments protected from weathering with classification of climatic conditions category 3K5, without condensing, icing, ice coating, water also from other sources different from rain and with temperature limits - 10 to +50°C according to EN 60 721-3-3 amend..A2. When the damper is furnished with electrical elements the temperature scope is reduced according to temperature limits of applied electrical elements.
- Optical smoke detector ORS 142K with socket 143A is intended for environments protected from weathering of categories 3K5/3Z1/3Z8/3B1/3C2/3S1/3M2 within temperature scope -25°C to +70°C, max. relative humidity 95% at 40°C, without condensing, icing and ice formation according to EN 60 721-3-3 amend.A2.
- If the damper is used for self-ventilation it must be furnished with grids from both sides.

**Fire resistance classification depending on installation method according to EN 13501-3+A1**

FDML installation method (sealing of penetration through walls)	Type and thickness of fire dividing wall structure	Fire resistance
Plaster / Mortar	Rigid wall or plasterboard structure, min. thickness 100 mm Connected duct with forcible air flow	EI 90 S, E 120 S
Mineral wool (density min.140kg/m <sup>3</sup> ) furnished with fire stop SEALANT (min. thickness 1 mm) (i.e. HILTI Acrylic sealant CFS-S ACR) and fire stop COATING, min., thickness 1 mm (for instance HILTI Firestop coating CFS-CT).	Rigid wall or plasterboard structure, min. thickness 100 mm Connected duct with forcible air flow	EI 90 S, E 120 S
Plaster / Mortar	The same installation possibilities like the two options before Without connected duct with grills on both sides and with natural air flow	EI 120

**Design**

**Design .40 and .50**

Servo drives with different torque strengths are used according to damper size. Two different servo finished products can be used, Belimo and Gruner. When Belimo actuators are used they are marked: (230V) BFL, BFN, BF 230-TN or (24V) BFL, BFN, BF 24-TN (hereinafter "servo") and when Gruner products are used their marking is (230V) 340TA-230D-03-S2/8F12, 340TA-230-05-S2/8F12, 360TA-230-12-S2/8F12, 360TA-230-20-S2/8F12 or (24V) 340TA-024D-03-S2/8F12, 340TA-024-05-S2/8F12, 360TA-024-12-S2/8F12, 360TA-024-20-S2/8F12. Actuators feature reverse spring loaded movement by 90° and include thermo-electric actuation devices reacting to temperature +72°C. Having been connected to 24 V or to 23 V AC/DC power supply respectively this device sets damper blade to working position OPEN and at the same time it switches over its own check spring. During the time when servo is under voltage, damper blade is in the position OPEN and check spring is tensioned. Time for complete opening of damper blade from CLOSED position to OPEN is max. 120s. If servo powering is interrupted (by loss of supply voltage or by pressing reset button on thermo-electric actuator BAT or when temperature exceeds +72°C), the check spring sets damper blade to emergency position CLOSED. Time for complete changeover of damper blade from OPEN position to CLOSED is max. 20 s. If supply voltage is restored (the blade may be in any position) servo starts to set the blade again to the position OPEN. This new opening of the damper does not occur spontaneously after restoration of supply voltage if fuses Tf1 and Tf2 have been activated (Tf1 with exceeding temperature in damper environment, Tf2 with exceeding of temperature inside air condition duct).

**Design .40 and .50**

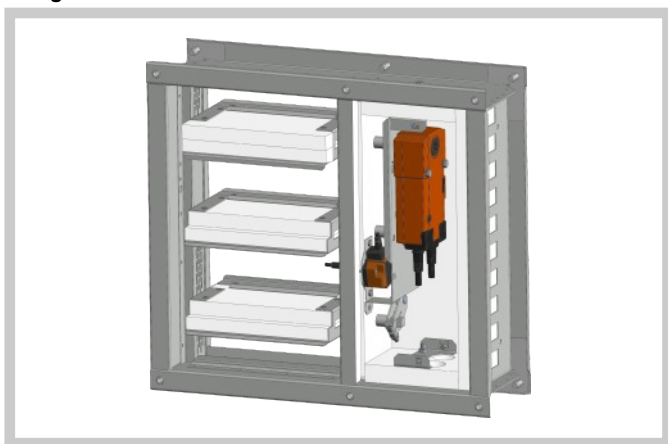

**Design .41 and .51**

Design .41 or .51 with actuating mechanism can be complemented with smoke detector ORS 142 K. The voltage can be 230 VAC or 24 V DC. Design with voltage AC 230 V is equipped with Communication and supply device ZPN-10-24 and with actuating mechanism BF 24-TN (BFL 24-T, BFN 24-T).

The smoke detector is activated when smoke spreads in air duct system. Deactivation of smoke detector is provided by interruption of supply voltage for min. 2s.

Signalisation of damper blade position "OPEN" a "CLOSE" is provided by two limit switches..

**Optical smoke detector**

**Optical smoke detector ORS 142 K with the socket 143A**

Optical smoke detector	ORS 142 K with socket 143A
Operating voltage	18 ... 28 V DC
Residual ripple	≤ 200 mV
Power Consumption Socket (without actuating mechanism)	max. 22 mA
Degree of protection	IP 42
Ambient temperature	- 20 °C ... + 75 °C
Additional temperature sensor	70 °C
Relay contact - max. switched voltage	30 V DC
Relay contact - max. switched current	1 A
Relay contact - max. Switched power	30 W
Weight	120 g
Connection - net - motor - communication and supply device BKN	Cabel 1m, connected to terminals 1, 2 and 4 Actuator connected on the terminals 2 and 5 Cabel 1m, connected to terminals 1, 2, 4 and 5

Smoke detector ORS 142 K and socket 143A

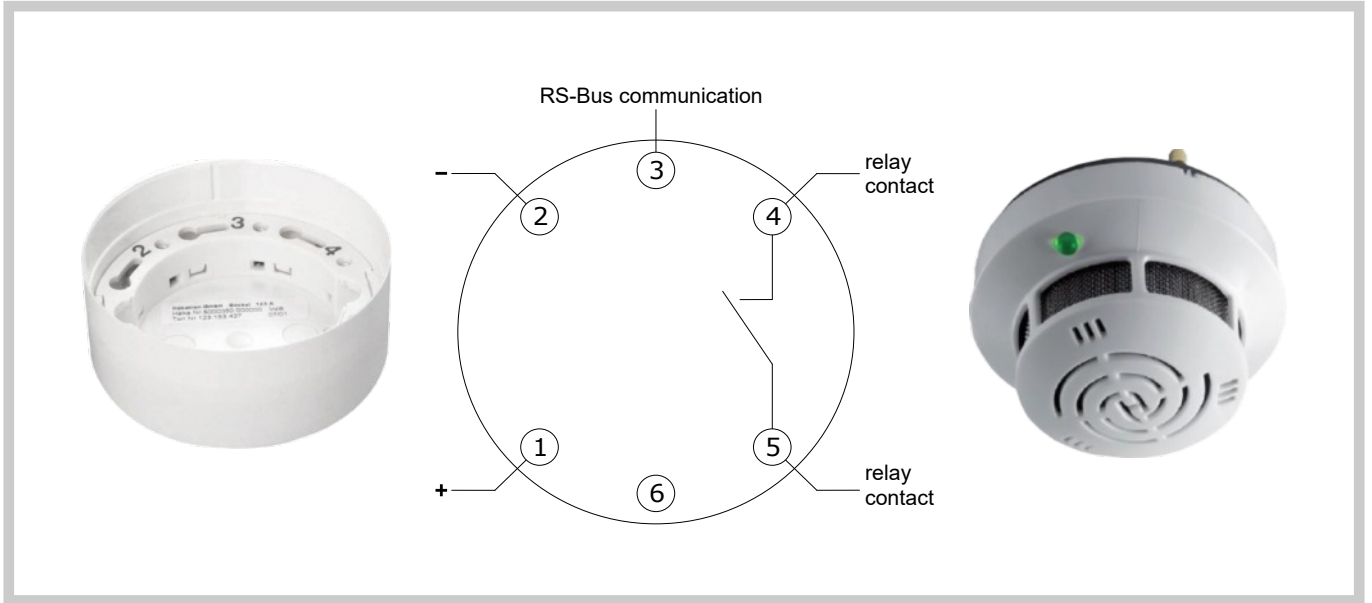

Wiring schematic diagram of model .41 - with servo drive BFL 24-T (BF 24-TN), smoke detector ORS 142 K and supply unit

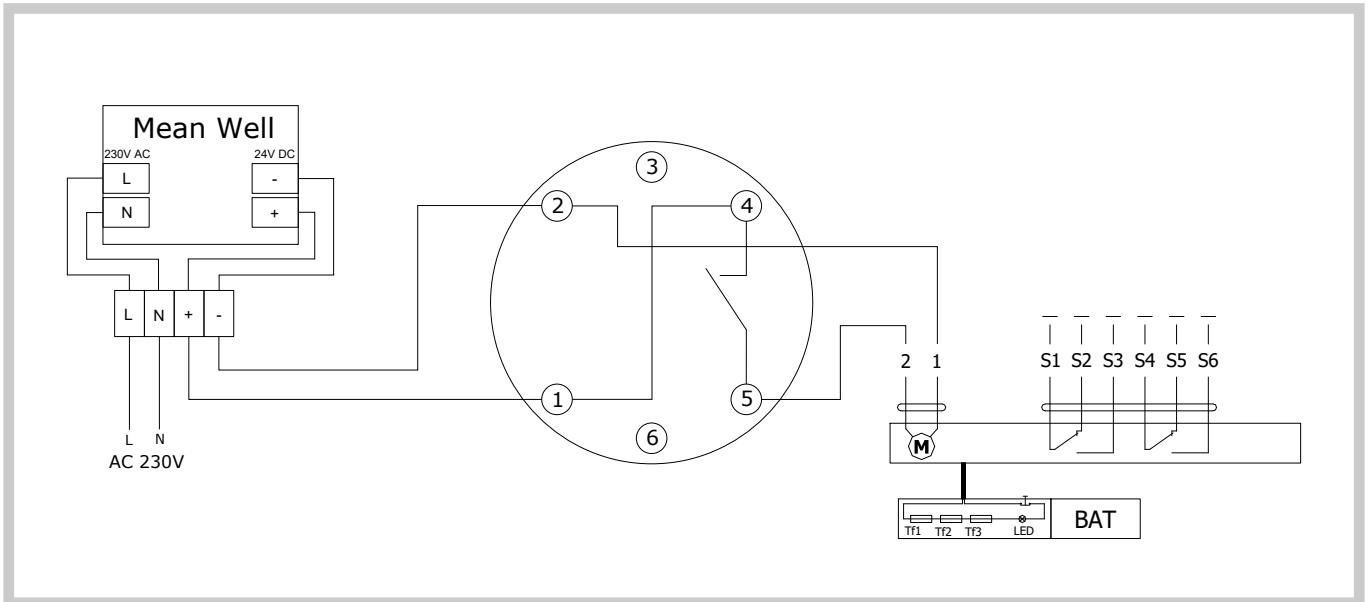

Wiring schematic diagram of model .51 - with servo drive BFL 24-T (BF 24-TN) and smoke detector ORS 142 K

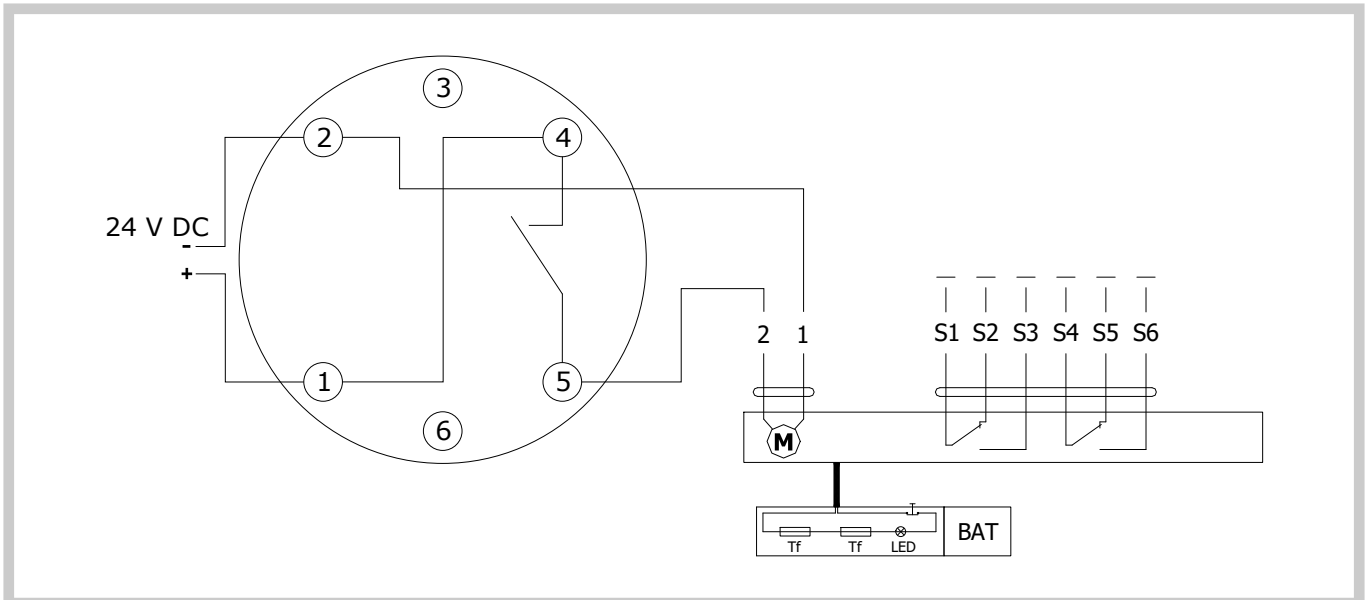

Dimensions and weights - atypical dimensions of closures are not manufactured!

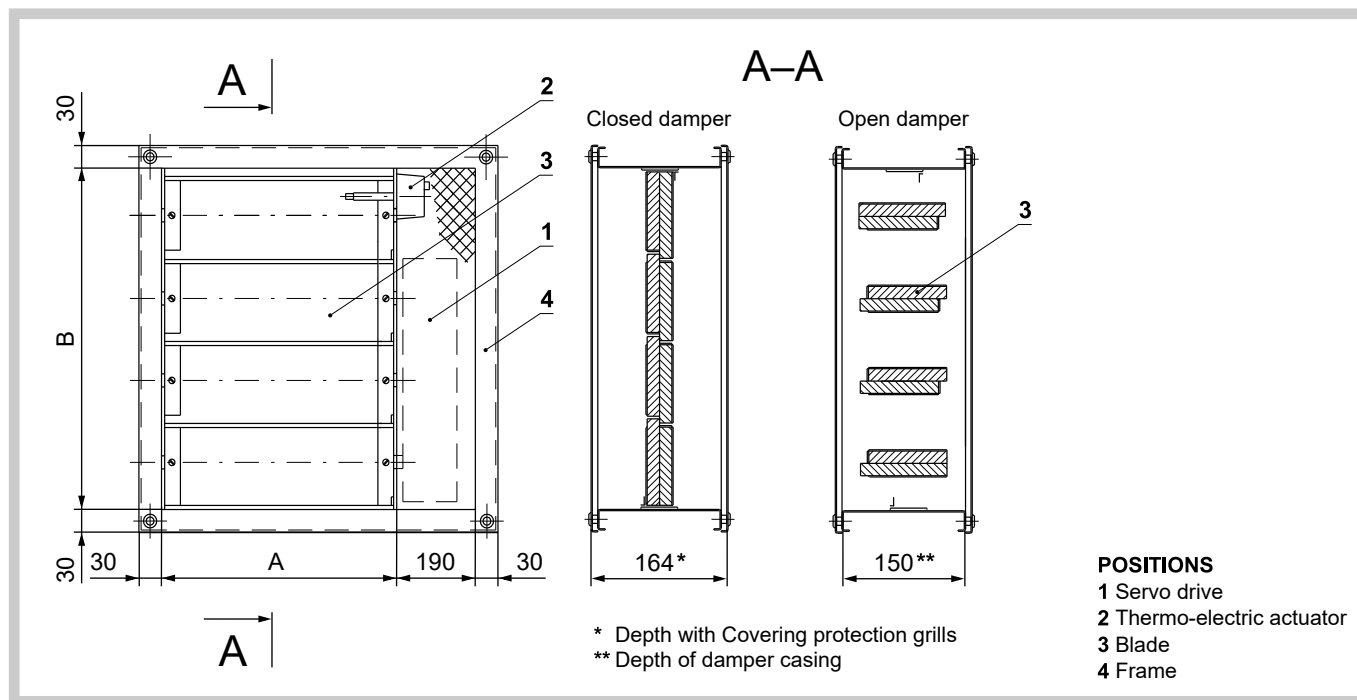

Dimensions and weight

A x B [mm]	Number of blades	Weig. FDML* [kg]	Weig. KMM** [kg]	Servo drive		S <sub>ef</sub> [m <sup>2</sup> ]	A x B [mm]	Number of blades	Weig. FDML* [kg]	Weig. KMM** [kg]	Servo drive		S <sub>ef</sub> [m <sup>2</sup> ]	
				Belimo	Gruner						Belimo	Gruner		
200 x 300	2	14	1	BFL	340TA-03	0,0276	280 x 300	2	15,6	1,2	BFL	340TA-03	0,0410	
x 315	2	14,6	1,1	BFL	340TA-03	0,0284		x 315	2	16,2	1,2	BFL	340TA-03	0,0422
x 355	3	16,1	1,1	BFL	340TA-03	0,0349		x 355	3	17,8	1,3	BFL	340TA-03	0,0520
x 400	3	17,5	1,2	BFL	340TA-03	0,0423		x 400	3	19,3	1,4	BFL	340TA-03	0,0630
x 450	4	19,8	1,3	BFL	340TA-03	0,0440		x 450	4	21,8	1,5	BFL	340TA-03	0,0654
x 500	4	21,5	1,4	BFL	340TA-03	0,0522		x 500	4	23,7	1,6	BFL	340TA-03	0,0776
x 560	4	23,7	1,5	BFL	340TA-03	0,0554		x 560	4	26,1	1,7	BFL	340TA-03	0,0825
x 600	5	25,1	1,6	BFL	340TA-03	0,0620		x 600	5	27,6	1,8	BFL	340TA-03	0,0922
x 630	5	26,1	1,7	BFL	340TA-03	0,0669		x 630	5	28,7	1,9	BFL	340TA-03	0,0996
x 650	5	26,7	1,7	BFL	340TA-03	0,0702		x 650	5	29,3	2,3	BFL	340TA-03	0,1044
x 700	6	28,7	1,8	BFL	340TA-03	0,0718		x 700	6	31,6	2,4	BFN	340TA-05	0,1069
x 710	6	29,2	1,8	BFL	340TA-03	0,0735		x 710	6	32,1	2,4	BFN	340TA-05	0,1093
x 750	6	30,5	1,9	BFL	340TA-03	0,0800		x 750	6	33,5	2,5	BFN	340TA-05	0,1191
x 800	6	32,3	2,4	BFL	340TA-03	0,0833		x 800	6	35,5	2,7	BFN	340TA-05	0,1240
x 850	7	34,1	2,5	BFL	340TA-03	0,0899		x 850	7	37,5	2,8	BFN	340TA-05	0,1337
x 900	7	35,7	2,6	BFN	340TA-03	0,0981		x 900	7	39,2	2,9	BFN	340TA-05	0,1459
x 950	8	37,7	2,7	BFN	340TA-03	0,0997	x 950	8	41,4	3	BFN	340TA-05	0,1484	
x 1000	8	39,3	2,9	BFN	340TA-03	0,1079	x 1000	8	43,2	3,1	BFN	340TA-05	0,1606	
250 x 300	2	15	1,1	BFL	340TA-03	0,0360	300 x 300	2	15,9	1,2	BFL	340TA-03	0,0444	
x 315	2	15,6	1,2	BFL	340TA-03	0,0370		x 315	2	16,6	1,2	BFL	340TA-03	0,0457
x 355	3	17,2	1,2	BFL	340TA-03	0,0456		x 355	3	18,2	1,3	BFL	340TA-03	0,0562
x 400	3	18,6	1,3	BFL	340TA-03	0,0552		x 400	3	19,8	1,4	BFL	340TA-03	0,0681
x 450	4	21,1	1,4	BFL	340TA-03	0,0574		x 450	4	22,3	1,5	BFL	340TA-03	0,0708
x 500	4	22,9	1,5	BFL	340TA-03	0,0681		x 500	4	24,2	1,6	BFL	340TA-03	0,0840
x 560	4	25,2	1,7	BFL	340TA-03	0,0723		x 560	4	26,7	1,8	BFL	340TA-03	0,0892
x 600	5	26,7	1,7	BFL	340TA-03	0,0809		x 600	5	28,3	1,9	BFL	340TA-03	0,0998
x 630	5	27,7	1,8	BFL	340TA-03	0,0873		x 630	5	29,3	2,3	BFL	340TA-03	0,1077
x 650	5	28,3	1,8	BFL	340TA-03	0,0916		x 650	5	30	2,4	BFL	340TA-03	0,1130
x 700	6	30,5	2,3	BFN	340TA-05	0,0937		x 700	6	32,3	2,5	BFN	340TA-05	0,1156
x 710	6	31	2,4	BFN	340TA-05	0,0959		x 710	6	32,8	2,5	BFN	340TA-05	0,1183
x 750	6	32,4	2,4	BFN	340TA-05	0,1044		x 750	6	34,3	2,6	BFN	340TA-05	0,1288
x 800	6	34,3	2,6	BFN	340TA-05	0,1087		x 800	6	36,3	2,7	BFN	340TA-05	0,1341
x 850	7	36,2	2,7	BFN	340TA-05	0,1173		x 850	7	38,3	2,8	BFN	340TA-05	0,1447
x 900	7	37,9	2,8	BFN	340TA-05	0,1280		x 900	7	40,1	3	BFN	340TA-05	0,1579
x 950	8	40	2,9	BFN	340TA-05	0,1301	x 950	8	42,3	3,1	BFN	340TA-05	0,1605	
x 1000	8	41,7	3	BFN	340TA-05	0,1408	x 1000	8	44,2	3,2	BFN	340TA-05	0,1737	

A x B [mm]	Number of blades	Weig. FDML* [kg]	Weig. KMM** [kg]	Servo drive		S <sub>ef</sub> [m <sup>2</sup> ]	A x B [mm]	Number of blades	Weig. FDML* [kg]	Weig. KMM** [kg]	Servo drive		S <sub>ef</sub> [m <sup>2</sup> ]
				Belimo	Gruner						Belimo	Gruner	
<b>315 x 300</b>	2	16,2	1,2	BFL	340TA-03	0,0469	<b>450 x 650</b>	5	35	2,8	BFN	340TA-05	0,1772
x 315	2	16,9	1,3	BFL	340TA-03	0,0483	x 700	6	37,6	2,9	BFN	340TA-05	0,1813
x 355	3	18,5	1,4	BFL	340TA-03	0,0594	x 710	6	38,2	3	BFN	340TA-05	0,1855
x 400	3	20,1	1,5	BFL	340TA-03	0,0720	x 750	6	39,9	3,1	BFN	340TA-05	0,2020
x 450	4	22,7	1,6	BFL	340TA-03	0,0748	x 800	6	42,5	3,2	BFN	340TA-05	0,2103
x 500	4	24,6	1,7	BFL	340TA-03	0,0887	x 850	7	44,6	3,3	BFN	360TA-12	0,2269
x 560	4	27,2	1,8	BFL	340TA-03	0,0943	x 900	7	46,7	3,5	BFN	360TA-12	0,2476
x 600	5	28,7	2,3	BFL	340TA-03	0,1055	x 950	8	49,3	3,6	BFN	360TA-12	0,2517
x 630	5	29,8	2,3	BFL	340TA-03	0,1138	x 1000	8	51,4	3,8	BFN	360TA-12	0,2724
x 650	5	30,5	2,4	BFL	340TA-03	0,1194	<b>500 x 300</b>	2	19,8	1,6	BFL	340TA-03	0,0780
x 700	6	32,8	2,5	BFN	340TA-05	0,1222	x 315	2	20,6	1,6	BFL	340TA-03	0,0803
x 710	6	33,4	2,5	BFN	340TA-05	0,1250	x 355	3	22,3	1,7	BFL	340TA-03	0,0988
x 750	6	34,8	2,6	BFN	340TA-05	0,1362	x 400	3	24,3	1,8	BFN	340TA-05	0,1197
x 800	6	36,9	2,8	BFN	340TA-05	0,1417	x 450	4	27,3	2,3	BFN	340TA-05	0,1244
x 850	7	39	2,9	BFN	340TA-05	0,1529	x 500	4	29,5	2,5	BFN	340TA-05	0,1476
x 900	7	40,7	3	BFN	340TA-05	0,1668	x 560	4	32,9	2,7	BFN	340TA-05	0,1568
x 950	8	43	3,2	BFN	340TA-05	0,1696	x 600	5	34,5	2,8	BFN	340TA-05	0,1754
x 1000	8	44,9	3,3	BFN	340TA-05	0,1836	x 630	5	35,8	2,9	BFN	340TA-05	0,1893
<b>355 x 300</b>	2	17	1,3	BFL	340TA-03	0,0536	x 650	5	36,6	2,9	BFN	340TA-05	0,1986
x 315	2	17,7	1,3	BFL	340TA-03	0,0552	x 700	6	39,4	3,1	BFN	360TA-12	0,2032
x 355	3	19,3	1,4	BFL	340TA-03	0,0679	x 710	6	40	3,1	BFN	360TA-12	0,2079
x 400	3	21	1,5	BFL	340TA-03	0,0823	x 750	6	41,8	3,2	BFN	360TA-12	0,2264
x 450	4	23,7	1,6	BFL	340TA-03	0,0855	x 800	6	44,5	3,4	BFN	360TA-12	0,2357
x 500	4	25,7	1,8	BFL	340TA-03	0,1014	x 850	7	46,7	3,5	BFN	360TA-12	0,2543
x 560	4	28,4	2,3	BFL	340TA-03	0,1078	x 900	7	48,9	3,7	BFN	360TA-12	0,2775
x 600	5	30	2,4	BFN	340TA-05	0,1206	x 950	8	51,7	3,8	BF	360TA-12	0,2821
x 630	5	31,1	2,5	BFN	340TA-05	0,1302	x 1000	8	53,9	4	BF	360TA-12	0,3053
x 650	5	31,8	2,5	BFN	340TA-05	0,1365	<b>560 x 300</b>	2	20,9	1,7	BFL	340TA-03	0,0880
x 700	6	34,2	2,6	BFN	340TA-05	0,1397	x 315	2	21,8	1,7	BFL	340TA-03	0,0907
x 710	6	34,8	2,7	BFN	340TA-05	0,1429	x 355	3	23,5	1,8	BFN	340TA-05	0,1116
x 750	6	36,3	2,8	BFN	340TA-05	0,1557	x 400	3	25,6	2,3	BFN	340TA-05	0,1352
x 800	6	38,6	2,9	BFN	340TA-05	0,1621	x 450	4	28,8	2,5	BFN	340TA-05	0,1404
x 850	7	40,6	3	BFN	340TA-05	0,1748	x 500	4	31,2	2,6	BFN	340TA-05	0,1666
x 900	7	42,5	3,2	BFN	340TA-05	0,1908	x 560	4	34,7	2,8	BFN	340TA-05	0,1771
x 950	8	44,9	3,3	BFN	360TA-12	0,1940	x 600	5	36,4	2,9	BFN	360TA-12	0,1981
x 1000	8	46,8	3,4	BFN	360TA-12	0,2099	x 630	5	37,7	3	BFN	360TA-12	0,2138
<b>400 x 300</b>	2	17,9	1,4	BFL	340TA-03	0,0612	x 650	5	38,6	3,1	BFN	360TA-12	0,2243
x 315	2	18,6	1,4	BFL	340TA-03	0,0630	x 700	6	41,6	3,3	BFN	360TA-12	0,2295
x 355	3	20,2	1,5	BFL	340TA-03	0,0775	x 710	6	42,2	3,3	BFN	360TA-12	0,2348
x 400	3	22	1,6	BFL	340TA-03	0,0939	x 750	6	44,1	3,4	BFN	360TA-12	0,2557
x 450	4	24,8	1,7	BFL	340TA-03	0,0976	x 800	6	46,9	3,6	BFN	360TA-12	0,2662
x 500	4	26,9	1,9	BFL	340TA-03	0,1158	x 850	7	49,3	3,7	BF	360TA-12	0,2872
x 560	4	29,8	2,4	BFL	340TA-03	0,1230	x 900	7	51,6	3,9	BF	360TA-12	0,3134
x 600	5	31,4	2,5	BFN	340TA-05	0,1376	x 950	8	54,5	4	BF	360TA-12	0,3186
x 630	5	32,5	2,6	BFN	340TA-05	0,1485	x 1000	8	56,8	4,2	BF	360TA-12	0,3448
x 650	5	33,3	2,6	BFN	340TA-05	0,1558	<b>600 x 300</b>	2	21,7	1,7	BFL	340TA-03	0,0948
x 700	6	35,8	2,8	BFN	340TA-05	0,1594	x 315	2	22,6	1,8	BFL	340TA-03	0,0976
x 710	6	36,4	2,8	BFN	340TA-05	0,1631	x 355	3	24,3	1,9	BFN	340TA-05	0,1201
x 750	6	38	2,9	BFN	340TA-05	0,1776	x 400	3	26,5	2,4	BFN	340TA-05	0,1455
x 800	6	40,4	3	BFN	340TA-05	0,1849	x 450	4	29,8	2,6	BFN	340TA-05	0,1512
x 850	7	42,5	3,2	BFN	360TA-12	0,1995	x 500	4	32,2	2,7	BFN	340TA-05	0,1794
x 900	7	44,5	3,3	BFN	360TA-12	0,2177	x 560	4	35,9	2,9	BFN	340TA-05	0,1906
x 950	8	47	3,5	BFN	360TA-12	0,2213	x 600	5	37,6	3,1	BFN	360TA-12	0,2132
x 1000	8	49	3,6	BFN	360TA-12	0,2395	x 630	5	39	3,1	BFN	360TA-12	0,2301
<b>450 x 300</b>	2	18,8	1,5	BFL	340TA-03	0,0696	x 650	5	40	3,2	BFN	360TA-12	0,2414
x 315	2	19,6	1,5	BFL	340TA-03	0,0716	x 700	6	43	3,4	BFN	360TA-12	0,2470
x 355	3	21,3	1,6	BFL	340TA-03	0,0882	x 710	6	43,7	3,4	BFN	360TA-12	0,2527
x 400	3	23,1	1,7	BFN	340TA-05	0,1068	x 750	6	45,6	3,5	BFN	360TA-12	0,2752
x 450	4	26	1,8	BFN	340TA-05	0,1110	x 800	6	48,6	3,7	BFN	360TA-12	0,2865
x 500	4	28,2	2,4	BFN	340TA-05	0,1317	x 850	7	51	3,8	BF	360TA-12	0,3091
x 560	4	31,3	2,5	BFN	340TA-05	0,1399	x 900	7	53,4	4	BF	360TA-12	0,3373
x 600	5	32,9	2,6	BFN	340TA-05	0,1565	x 950	8	56,3	4,2	BF	360TA-12	0,3429
x 630	5	34,1	2,7	BFN	340TA-05	0,1689	x 1000	8	58,7	4,3	BF	360TA-12	0,3711

A x B [mm]	Numb er of blades	Weig. FDML* [kg]	Weig. KMM** [kg]	Servo drive		S <sub>ef</sub> [m <sup>2</sup> ]	A x B [mm]	Numb er of blades	Weig. FDML* [kg]	Weig. KMM** [kg]	Servo drive		S <sub>ef</sub> [m <sup>2</sup> ]
				Belimo	Gruner						Belimo	Gruner	
<b>630 x 300</b>	2	22,2	1,8	BFL	340TA-03	0,0998	<b>710 x 650</b>	5	43,6	3,5	BFN	360TA-12	0,2885
x 315	2	23,2	1,8	BFL	340TA-03	0,1028	x 700	6	46,9	3,7	BF	360TA-12	0,2952
x 355	3	25	1,9	BFN	340TA-05	0,1265	x 710	6	47,7	3,7	BF	360TA-12	0,3020
x 400	3	27,1	2,5	BFN	340TA-05	0,1533	x 750	6	49,7	3,9	BF	360TA-12	0,3289
x 450	4	30,5	2,6	BFN	340TA-05	0,1592	x 800	6	53,1	4	BF	360TA-12	0,3424
x 500	4	33	2,8	BFN	340TA-05	0,1889	x 850	7	55,6	4,2	BF	360TA-12	0,3694
x 560	4	36,9	3	BFN	340TA-05	0,2008	x 900	7	58,2	4,4	BF	360TA-12	0,4031
x 600	5	38,6	3,1	BFN	360TA-12	0,2245	x 950	8	61,5	4,6	BF	360TA-12	0,4098
x 630	5	40	3,2	BFN	360TA-12	0,2424	x 1000	8	64,1	4,7	BF	360TA-12	0,4435
x 650	5	41	3,3	BFN	360TA-12	0,2542	<b>750 x 300</b>	2	24,5	2	BFL	340TA-03	0,1200
x 700	6	44,1	3,5	BFN	360TA-12	0,2602	x 315	2	25,6	2	BFL	340TA-03	0,1235
x 710	6	44,7	3,5	BFN	360TA-12	0,2661	x 355	3	27,4	2,6	BFN	340TA-05	0,1521
x 750	6	46,7	3,6	BFN	360TA-12	0,2899	x 400	3	29,8	2,8	BFN	340TA-05	0,1842
x 800	6	49,8	3,8	BFN	360TA-12	0,3018	x 450	4	33,5	2,9	BFN	360TA-12	0,1914
x 850	7	52,2	3,9	BF	360TA-12	0,3255	x 500	4	36,3	3,1	BFN	360TA-12	0,2271
x 900	7	54,7	4,1	BF	360TA-12	0,3552	x 560	4	40,6	3,3	BFN	360TA-12	0,2413
x 950	8	57,7	4,3	BF	360TA-12	0,3612	x 600	5	42,3	3,5	BFN	360TA-12	0,2699
x 1000	8	60,2	4,4	BF	360TA-12	0,3909	x 630	5	43,9	3,6	BFN	360TA-12	0,2913
<b>650 x 300</b>	2	22,6	1,8	BFL	340TA-03	0,1032	x 650	5	45	3,6	BFN	360TA-12	0,3056
x 315	2	23,6	1,9	BFL	340TA-03	0,1062	x 700	6	48,4	3,8	BF	360TA-12	0,3127
x 355	3	25,4	2	BFN	340TA-05	0,1308	x 710	6	49,1	3,9	BF	360TA-12	0,3199
x 400	3	27,6	2,5	BFN	340TA-05	0,1584	x 750	6	51,2	4	BF	360TA-12	0,3484
x 450	4	31	2,7	BFN	340TA-05	0,1646	x 800	6	54,7	4,2	BF	360TA-12	0,3627
x 500	4	33,6	2,9	BFN	340TA-05	0,1953	x 850	7	57,3	4,3	BF	360TA-12	0,3913
x 560	4	37,5	3,1	BFN	340TA-05	0,2075	x 900	7	60	4,5	BF	360TA-12	0,4270
x 600	5	39,2	3,2	BFN	360TA-12	0,2321	x 950	8	63,3	4,7	BF	360TA-12	0,4341
x 630	5	40,6	3,3	BFN	360TA-12	0,2505	x 1000	8	66	4,9	BF	360TA-12	0,4698
x 650	5	41,6	3,4	BFN	360TA-12	0,2628	<b>800 x 300</b>	2	25,5	2,1	BFL	340TA-03	0,1284
x 700	6	44,8	3,5	BF	360TA-12	0,2689	x 315	2	26,6	2,6	BFL	340TA-03	0,1322
x 710	6	45,5	3,6	BF	360TA-12	0,2751	x 355	3	28,5	2,7	BFN	340TA-05	0,1627
x 750	6	47,5	3,7	BF	360TA-12	0,2996	x 400	3	31	2,8	BFN	340TA-05	0,1971
x 800	6	50,6	3,8	BF	360TA-12	0,3119	x 450	4	34,7	3	BFN	360TA-12	0,2048
x 850	7	53,1	4	BF	360TA-12	0,3365	x 500	4	37,6	3,2	BFN	360TA-12	0,2430
x 900	7	55,6	4,2	BF	360TA-12	0,3672	x 560	4	42,1	3,5	BFN	360TA-12	0,2582
x 950	8	58,7	4,3	BF	360TA-12	0,3733	x 600	5	43,9	3,6	BF	360TA-12	0,2888
x 1000	8	61,2	4,5	BF	360TA-12	0,4040	x 630	5	45,5	3,7	BF	360TA-12	0,3117
<b>700 x 300</b>	2	23,6	1,9	BFL	340TA-03	0,1116	x 650	5	46,7	3,8	BF	360TA-12	0,3270
x 315	2	24,6	1,9	BFL	340TA-03	0,1149	x 700	6	50,2	4	BF	360TA-12	0,3346
x 355	3	26,4	2,5	BFN	340TA-05	0,1414	x 710	6	50,9	4	BF	360TA-12	0,3423
x 400	3	28,7	2,6	BFN	340TA-05	0,1713	x 750	6	53,1	4,1	BF	360TA-12	0,3728
x 450	4	32,2	2,8	BFN	360TA-12	0,1780	x 800	6	56,8	4,3	BF	360TA-12	0,3881
x 500	4	34,9	3	BFN	360TA-12	0,2112	x 850	7	59,4	4,5	BF	360TA-12	0,4187
x 560	4	39	3,2	BFN	360TA-12	0,2244	x 900	7	62,2	4,7	BF	360TA-12	0,4569
x 600	5	40,7	3,3	BFN	360TA-12	0,2510	x 950	8	65,7	4,9	BF	360TA-12	0,4645
x 630	5	42,3	3,4	BFN	360TA-12	0,2709	x 1000	8	68,4	5,1	BF	360TA-12	0,5027
x 650	5	43,3	3,5	BFN	360TA-12	0,2842	<b>850 x 300</b>	2	26,4	2,6	BFN	340TA-05	0,1368
x 700	6	46,6	3,7	BF	360TA-12	0,2908	x 315	2	27,6	2,7	BFN	340TA-05	0,1408
x 710	6	47,3	3,7	BF	360TA-12	0,2975	x 355	3	29,5	2,8	BFN	340TA-05	0,1734
x 750	6	49,4	3,8	BF	360TA-12	0,3240	x 400	3	32,1	3	BFN	340TA-05	0,2100
x 800	6	52,7	4	BF	360TA-12	0,3373	x 450	4	36	3,2	BFN	360TA-12	0,2182
x 850	7	55,2	4,2	BF	360TA-12	0,3639	x 500	4	38,9	3,4	BFN	360TA-12	0,2589
x 900	7	57,8	4,4	BF	360TA-12	0,3971	x 560	4	43,6	3,6	BFN	360TA-12	0,2751
x 950	8	61	4,5	BF	360TA-12	0,4037	x 600	5	45,5	3,7	BF	360TA-12	0,3077
x 1000	8	63,6	4,7	BF	360TA-12	0,4369	x 630	5	47,2	3,8	BF	360TA-12	0,3321
<b>710 x 300</b>	2	23,8	1,9	BFL	340TA-03	0,1132	x 650	5	48,3	3,9	BF	360TA-12	0,3484
x 315	2	24,8	2	BFL	340TA-03	0,1166	x 700	6	51,9	4,1	BF	360TA-12	0,3565
x 355	3	26,6	2,5	BFN	340TA-05	0,1436	x 710	6	52,7	4,1	BF	360TA-12	0,3647
x 400	3	28,9	2,7	BFN	340TA-05	0,1739	x 750	6	55	4,3	BF	360TA-12	0,3972
x 450	4	32,5	2,8	BFN	360TA-12	0,1806	x 800	6	58,8	4,5	BF	360TA-12	0,4135
x 500	4	35,2	3	BFN	360TA-12	0,2143	x 850	7	61,5	4,7	BF	360TA-12	0,4461
x 560	4	39,3	3,2	BFN	360TA-12	0,2278	x 900	7	64,4	4,9	BF	360TA-12	0,4868
x 600	5	41,1	3,4	BFN	360TA-12	0,2548	x 950	8	68	5,1	BF	360TA-20	0,4949
x 630	5	42,6	3,5	BFN	360TA-12	0,2750	x 1000	8	70,9	5,2	BF	360TA-20	0,5356



A x B [mm]	Number of blades	Weig. FDML* [kg]	Weig. KMM** [kg]	Servo drive		S <sub>ef</sub> [m <sup>2</sup> ]	A x B [mm]	Number of blades	Weig. FDML* [kg]	Weig. KMM** [kg]	Servo drive		S <sub>ef</sub> [m <sup>2</sup> ]
				Belimo	Gruner						Belimo	Gruner	
900 x 300	2	27,4	2,7	BFN	340TA-05	0,1452	950 x 650	5	51,6	4,2	BF	360TA-12	0,3912
x 315	2	28,6	2,8	BFN	340TA-05	0,1495	x 700	6	55,5	4,4	BF	360TA-12	0,4003
x 355	3	30,5	2,9	BFN	340TA-05	0,1840	x 710	6	56,3	4,4	BF	360TA-12	0,4095
x 400	3	33,2	3,1	BFN	340TA-05	0,2229	x 750	6	58,8	4,6	BF	360TA-12	0,4460
x 450	4	37,2	3,3	BFN	360TA-12	0,2316	x 800	6	62,9	4,8	BF	360TA-12	0,4643
x 500	4	40,3	3,5	BFN	360TA-12	0,2748	x 850	7	65,7	5	BF	360TA-20	0,5009
x 560	4	45,2	3,7	BFN	360TA-12	0,2920	x 900	7	68,8	5,2	BF	360TA-20	0,5466
x 600	5	47	3,9	BF	360TA-12	0,3266	x 950	8	72,6	5,4	BF	360TA-20	0,5557
x 630	5	48,8	4	BF	360TA-12	0,3525	x 1000	8	75,7	5,6	BF	360TA-20	0,6014
x 650	5	50	4,1	BF	360TA-12	0,3698	1000 x 300	2	29,3	2,9	BFN	340TA-05	0,1620
x 700	6	53,7	4,3	BF	360TA-12	0,3784	x 315	2	30,6	3	BFN	340TA-05	0,1668
x 710	6	54,5	4,3	BF	360TA-12	0,3871	x 355	3	32,6	3,1	BFN	360TA-12	0,2053
x 750	6	56,9	4,5	BF	360TA-12	0,4216	x 400	3	35,5	3,3	BFN	360TA-12	0,2487
x 800	6	60,8	4,6	BF	360TA-12	0,4389	x 450	4	39,7	3,5	BF	360TA-12	0,2584
x 850	7	63,6	4,8	BF	360TA-12	0,4735	x 500	4	43	3,7	BF	360TA-12	0,3066
x 900	7	66,6	5	BF	360TA-12	0,5167	x 560	4	48,3	4	BF	360TA-12	0,3258
x 950	8	70,3	5,2	BF	360TA-20	0,5253	x 600	5	50,1	4,1	BF	360TA-12	0,3644
x 1000	8	73,3	5,4	BF	360TA-20	0,5685	x 630	5	52	4,3	BF	360TA-12	0,3933
950 x 300	2	28,3	2,8	BFN	340TA-05	0,1536	x 650	5	53,3	4,4	BF	360TA-12	0,4126
x 315	2	29,6	2,9	BFN	340TA-05	0,1581	x 700	6	57,3	4,6	BF	360TA-12	0,4222
x 355	3	31,6	3	BFN	360TA-12	0,1947	x 710	6	58,1	4,6	BF	360TA-12	0,4319
x 400	3	34,3	3,2	BFN	360TA-12	0,2358	x 750	6	60,7	4,8	BF	360TA-12	0,4704
x 450	4	38,5	3,4	BFN	360TA-12	0,2450	x 800	6	64,9	5	BF	360TA-12	0,4897
x 500	4	41,6	3,6	BFN	360TA-12	0,2907	x 850	7	67,8	5,2	BF	360TA-20	0,5283
x 560	4	46,7	3,8	BFN	360TA-12	0,3089	x 900	7	71	5,4	BF	360TA-20	0,5765
x 600	5	48,6	4	BF	360TA-12	0,3455	x 950	8	75	5,6	BF	360TA-20	0,5861
x 630	5	50,4	4,1	BF	360TA-12	0,3729	x 1000	8	78,2	5,8	BF	360TA-20	0,6343

\* Weight of fire damper FDML without actuator and grille. Should be attributed to the weight of actuator, by selection (BELIMO or GRUNER)

\*\* Weight of one grille (KMM). Should be attributed to the weight, according to the number of grilles (1 or 2 grilles)

Weights of actuators

BELIMO [kg]		GRUNER [kg]	
BFL	1,2	340TA-03	1,2
BFN	1,5	340TA-05	1,2
BF	3,1	360TA-12	1,8
-	-	360TA-20	2,4

Connecting dimensions M6 nuts

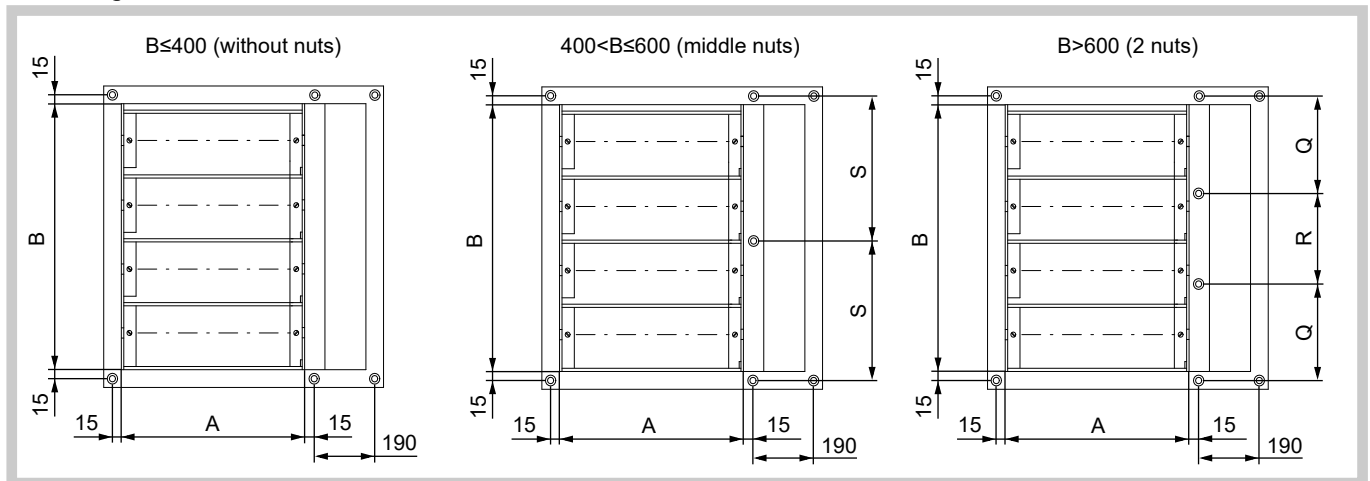

B [mm]	R [mm]	Q [mm]	S [mm]	B [mm]	R [mm]	Q [mm]	S [mm]
300	-	-	-	650	220	230	-
315	-	-	-	700	240	245	-
355	-	-	-	710	240	250	-
400	-	-	-	750	250	265	-
450	-	-	240	800	270	280	-
500	-	-	265	850	290	295	-
560	-	-	295	900	300	315	-
600	-	-	315	950	320	330	-
630	210	225	-	1000	340	345	-

Electrical components, wiring diagram

**BELIMO actuators**

Wiring diagram of the actuator BFL 230-T, BFN 230-T

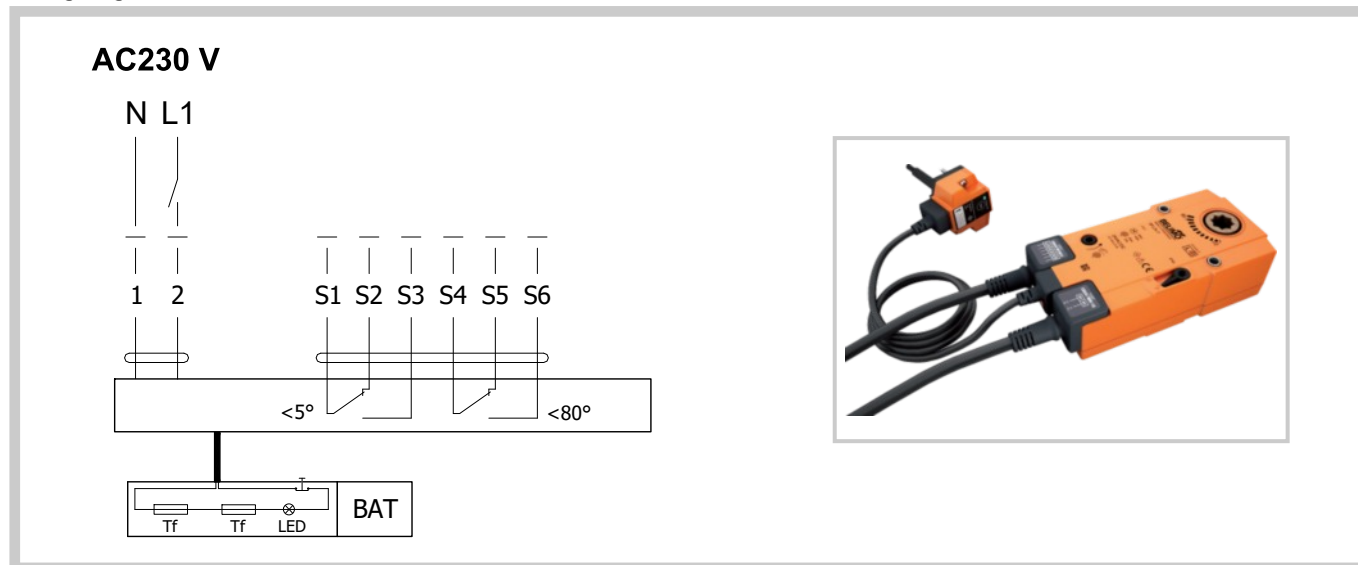

Wiring diagram of the actuator BFL 24-T, BFN 24-T

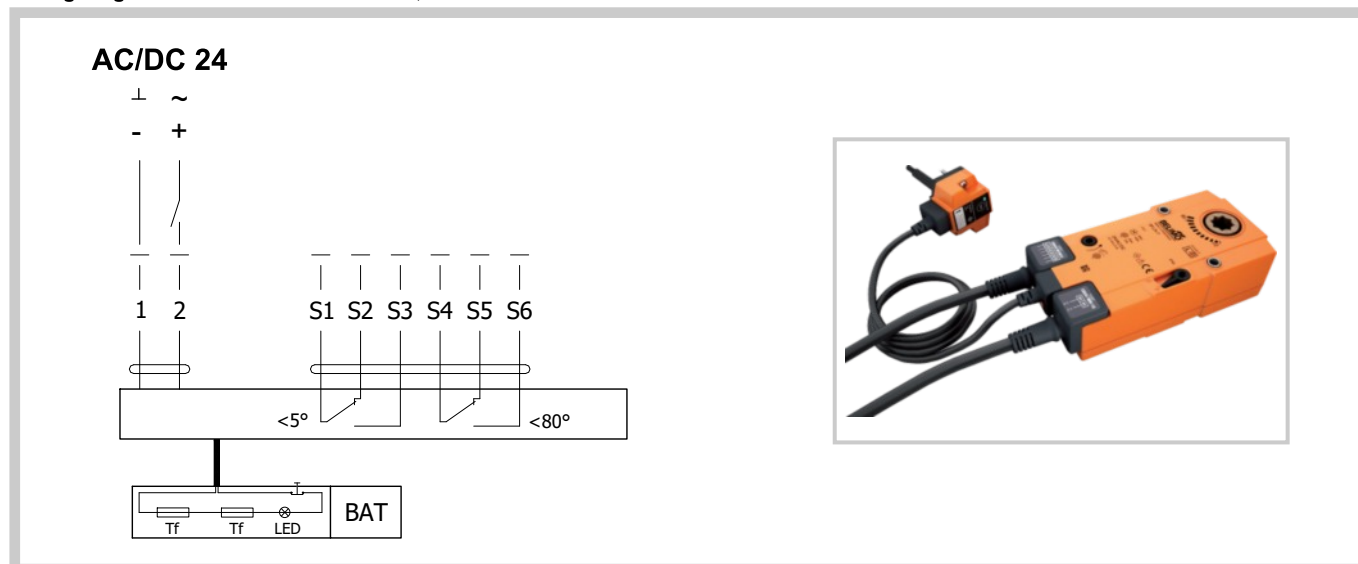

Electrical data for actuators BFL 24-T(-ST), BFN 24-T(-ST), BFL 230-T, BFN 230-T

ACTUATING MECHANISM BELIMO	BFL, BFN 230-T	BFL, BFN 24-T(-ST)
<b>Nominal voltage</b>	AC 230 V 50/60 Hz	AC 24 V 50/60 Hz DC 24 V
<b>Power consumption</b> - motoring - holding	3,5/5 W 1,1/2,1 W	2,5/4 W 0,8/1,4 W
<b>Dimensioning</b>	6,5/10 VA (I <sub>max</sub> 4 A @ 5 ms)	4/6 VA (I <sub>max</sub> 8,3 A @ 5 ms)
<b>Protection class</b>	II	III
<b>Degree of protection</b>	IP 54	
<b>Running time</b> - motor - spring return	<60 s ~ 20 s	
<b>Ambient temperature</b> - normal duty - safety duty - non-operating temperature	- 30 °C ... 55 °C The safe position will be attained up to max. 75 °C - 40 °C ... 55 °C	
<b>Connecting</b> - motor - auxiliary switch	cable 1 m, 2 x 0,75 mm <sup>2</sup> (BFL/BFN 24-T-ST) with 3-pin plug-in connectors cable 1 m, 6 x 0,75 mm <sup>2</sup> (BFL/BFN 24-T-ST) with 6-pin plug-in connectors	
<b>Thermal trips</b>	duct outside temperature 72 °C duct inside temperature 72 °C	

Actuating mechanism BELIMO BF 230-TN, BF 24-TN (-ST)

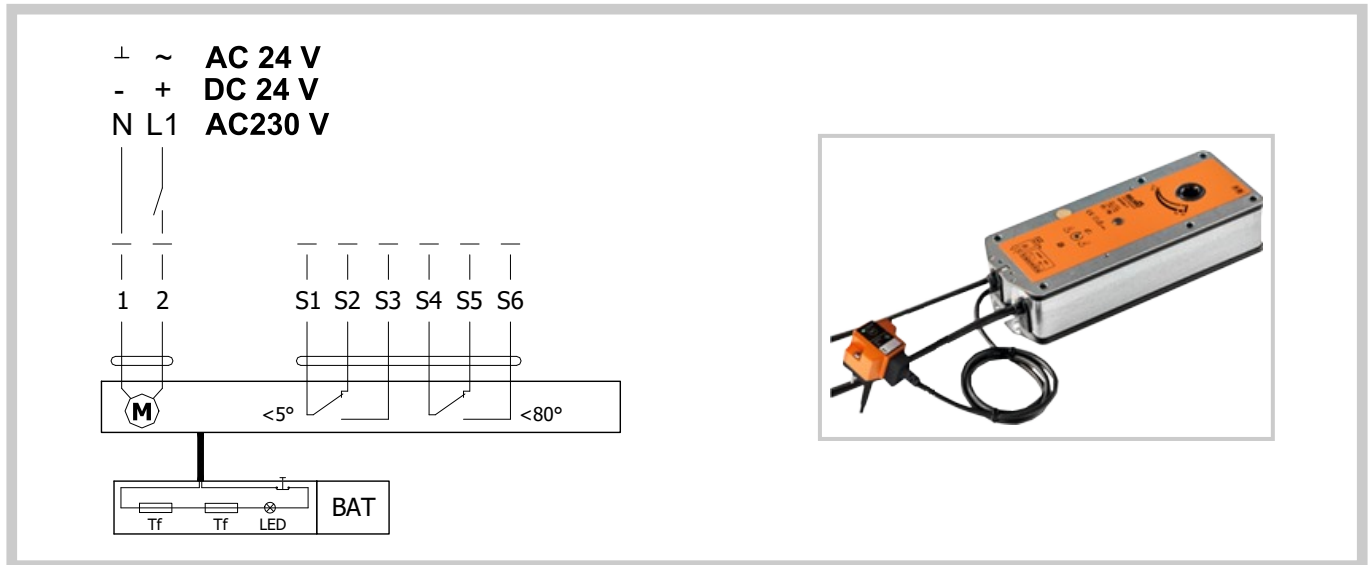

Actuating mechanism BELIMO BF 24-TN(-ST), BF 230-TN

Actuating mechanism BELIMO	BF 24-TN	BF 230-TN
Nominal voltage	24V AC/DC 50/60 Hz	230V 50/60 Hz
Power consumption - motoring - holding	7 W 2 W	8 W 3 W
Dimensioning	10 VA (I <sub>max</sub> 8,3 A @ 5 ms)	12,5 VA (I <sub>max</sub> 500 mA @ 5 ms)
Protection class	III	II
Degree of protection	IP 54	
Running time - motor - spring return	120 s ~ 16 s	
Ambient Temperature - normal duty - safety duty - non-operating temperature	- 30 °C ... + 50 °C The safe position will be attained up to max. 75°C - 40 °C ... + 50 °C	
Connecting - motor - auxiliary switch	cable 1 m, 2 x 0,75 mm <sup>2</sup> cable 1 m, 6 x 0,75 mm <sup>2</sup>	
Thermal trips	Tf1: duct outside temperature Duct 72 °C Tf2/Tf3: duct inside temperature Duct 72 °C	

**GRUNER actuators**

**GRUNER servo wiring diagram for mains voltage VAC**

**Caution!**

- Attention: Mains voltage!
- Servo must be protected by breaker max. 16 A.
- Parallel connection of other servo drives is possible. Respect power input data.
- Combination of mains voltage and use of signals from limit switches by very low voltage is not allowed.



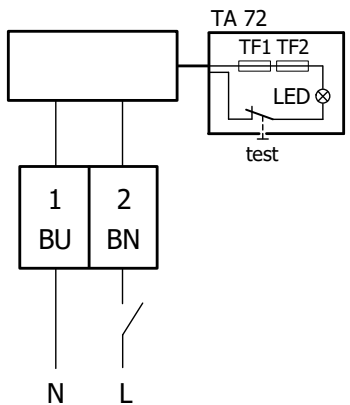

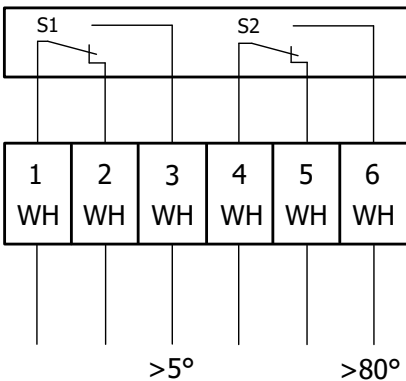

**Cable colours:**

- BU1 = blue
- BN2 = brown
- WH1 = white
- WH2 = white
- WH3 = white
- WH4 = white
- WH5 = white
- WH6 = white

**GRUNER servo wiring diagram for mains voltage 24 VAC/DC**

**Caution!**

- Connect through separating transformer!
- Parallel connection of other servo drives is possible. Respect power input data.
- Combination of mains voltage and use of signals from limit switches by very low voltage is not allowed.



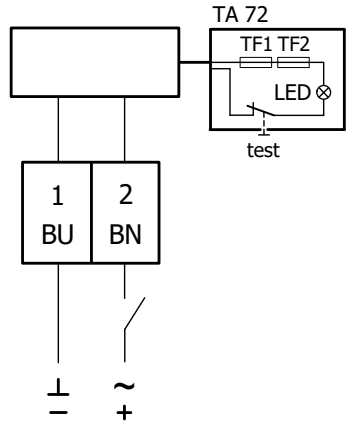

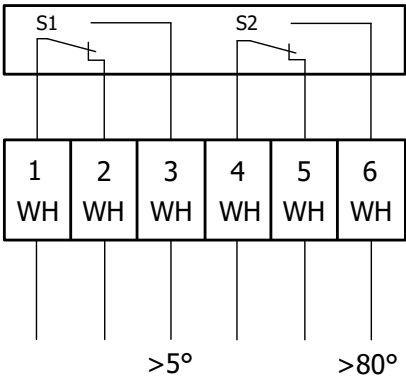

**Cable colours:**

- BU1 = blue
- BN2 = brown
- WH1 = white
- WH2 = white
- WH3 = white
- WH4 = white
- WH5 = white
- WH6 = white

**Electrical parameters of GRUNER actuators 340TA-230D-03-S2/8F12, GRUNER 340TA-024D-03-S2/8F12**

Actuating mechanism GRUNER - 3 Nm	340TA-230D-03-S2/8F12	340TA-024D-03-S2/8F12
Nominal voltage	230V 50/60 Hz	24V AC/DC 50/60 Hz
Power consumption - motoring - holding	4 W 1 W	4,5 W 1 W
Dimensioning	9 VA	6 VA
Protection class	II	III
Degree of protection	IP 54	
Running time - motor - spring return	< 40 s < 20 s	
Ambient Temperature - normal duty - safety duty - non-operating temperature	-30 °C ... +50 °C > +75 °C -30 °C ... +50 °C	
Connecting - motor - auxiliary switch	cable 1 m, 2 x 0,75 mm <sup>2</sup> cable 1 m, 6 x 0,75 mm <sup>2</sup>	
Thermal trips	TF1 temperature inside Duct +72 °C TF2 temperature outside Duct +71 °C	

## Electrical parameters of GRUNER actuators 340TA-230-05-S2/8F12, GRUNER 340TA-024-05-S2/8F12

Actuating mechanism GRUNER - 5 Nm	340TA-230-05-S2/8F12	340TA-024-05-S2/8F12
Nominal voltage	230V 50/60 Hz	24V AC/DC 50/60 Hz
Power consumption - motoring - holding	5,5 W 2 W	6,5 W 2 W
Dimensioning	9,5 VA	9 VA
Protection class	II	III
Degree of protection	IP 54	
Running time - motor - spring return	< 75 s < 20 s	
Ambient Temperature - normal duty - safety duty - non-operating temperature	-30 °C ... +50 °C > +75°C -30 °C ... +50 °C	
Connecting - motor - auxiliary switch	cable 1 m, 2 x 0,75 mm <sup>2</sup> cable 1 m, 6 x 0,75 mm <sup>2</sup>	
Thermal trips	TF1 temperature inside Duct +72 °C TF2 temperature outside Duct +71 °C	

## Electrical parameters of GRUNER actuators 360TA-230-12-S2/8F12, GRUNER 360TA-024-12-S2/8F12

Actuating mechanism GRUNER - 12 Nm	360TA-230-12-S2/8F12	360TA-024-12-S2/8F12
Nominal voltage	230V 50/60 Hz	24V AC/DC 50/60 Hz
Power consumption - motoring - holding	5,5 W 1,5 W	5 W 2 W
Dimensioning	11,5 VA	7 VA
Protection class	II	III
Degree of protection	IP 54	
Running time - motor - spring return	< 75 s < 20 s	
Ambient Temperature - normal duty - safety duty - non-operating temperature	-30 °C ... +50 °C > +75°C -30 °C ... +50 °C	
Connecting - motor - auxiliary switch	cable 1 m, 2 x 0,75 mm <sup>2</sup> cable 1 m, 6 x 0,75 mm <sup>2</sup>	
Thermal trips	TF1 temperature inside Duct +72 °C TF2 temperature outside Duct +71 °C	

## Electrical parameters of GRUNER actuators 360TA-230-20-S2/8F12, GRUNER 360TA-024-20-S2/8F12

Actuating mechanism GRUNER - 20 Nm	360TA-230-20-S2/8F12	360TA-024-20-S2/8F12
Nominal voltage	230V 50/60 Hz	24V AC/DC 50/60 Hz
Power consumption - motoring - holding	10,5 W 2,5 W	10,5 W 2,5 W
Dimensioning	22,5 VA	14 VA
Protection class	II	III
Degree of protection	IP 54	
Running time - motor - spring return	< 75 s < 20 s	
Ambient Temperature - normal duty - safety duty - non-operating temperature	-30 °C ... +50 °C > +75°C -30 °C ... +50 °C	
Connecting - motor - auxiliary switch	cable 1 m, 2 x 0,75 mm <sup>2</sup> cable 1 m, 6 x 0,75 mm <sup>2</sup>	
Thermal trips	TF1 temperature inside Duct +72 °C TF2 temperature outside Duct +71 °C	

**Installation and placement**

Dampers can be in-built in rigid wall structures made from concrete, porous concrete, bricks a light plasterboard wall structures with min. thickness 100 mm. Dampers must be placed within wall structures to ensure optimal conditions for temperature scanning, i.e. the thermo-electric actuator must be located in damper upper part. Optimal conditions for smoke scanning must be ensured with optical smoke detector versions, i.e. the smoke detector must be in upper part of particular room.

Distance between the damper and structure (wall) must be at least 75 mm. When two or more dampers are to be inbuilt in one fire dividing structure, the distance between neighbouring dampers must be minimally 200 mm. Dampers must be installed in a way that transfer of load effects from any walls, structures and other parts onto damper frame are excluded completely.

During walling-in the damper frame must not be deformed. After having been built-in the damper, its blades must not rub on damper frame or one another. When dampers are installed in walls, they must be built-in in such a way so that the damper side with thermo-electric actuator mates with the wall and that hole on wall other side is permanently covered with the second Covering grill attached to the frame for instance. The minimum thickness of the standard wall construction is 100 mm. In the case of an installation where one side of the damper aligns with the surface of the structure and the other side protrudes from the structure by more than 25 mm, the protruding part must be covered with fire-resistant boards. When the damper is installed into a plasterboard wall, the opening for closure must be bordered with reinforcing sections.

**Recommended dimensions of structural holes**

**Recommended dimensions of structural holes in rigid wall structures**

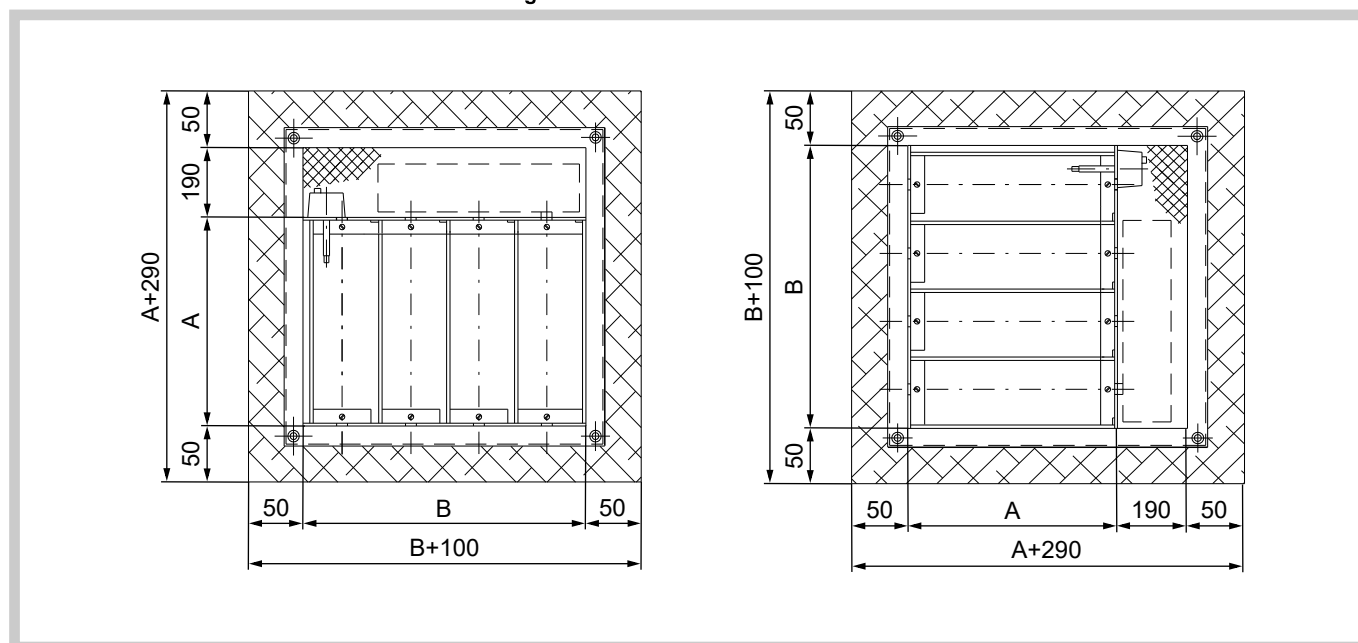

**Installation method and recommended dimensions of structural holes in rigid wall structures**

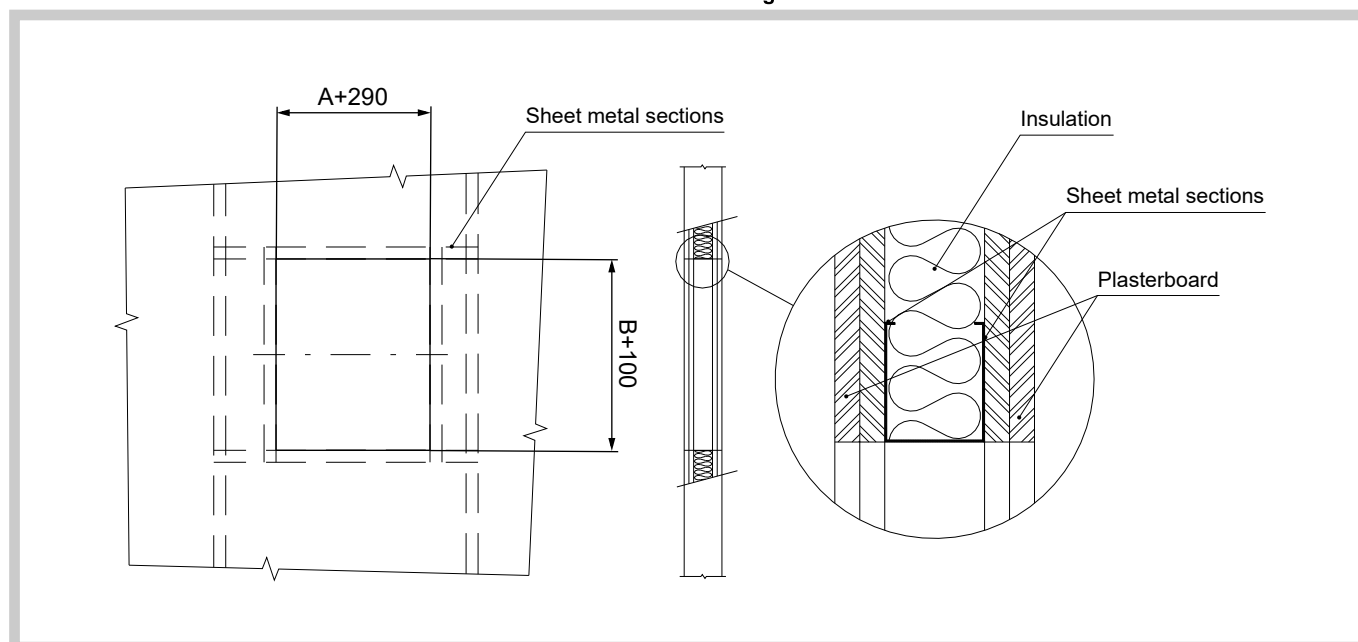

**Examples of in-built fire dampers into rigid wall structures**

**Installation method into rigid wall structure - PLASTER – MORTAR**

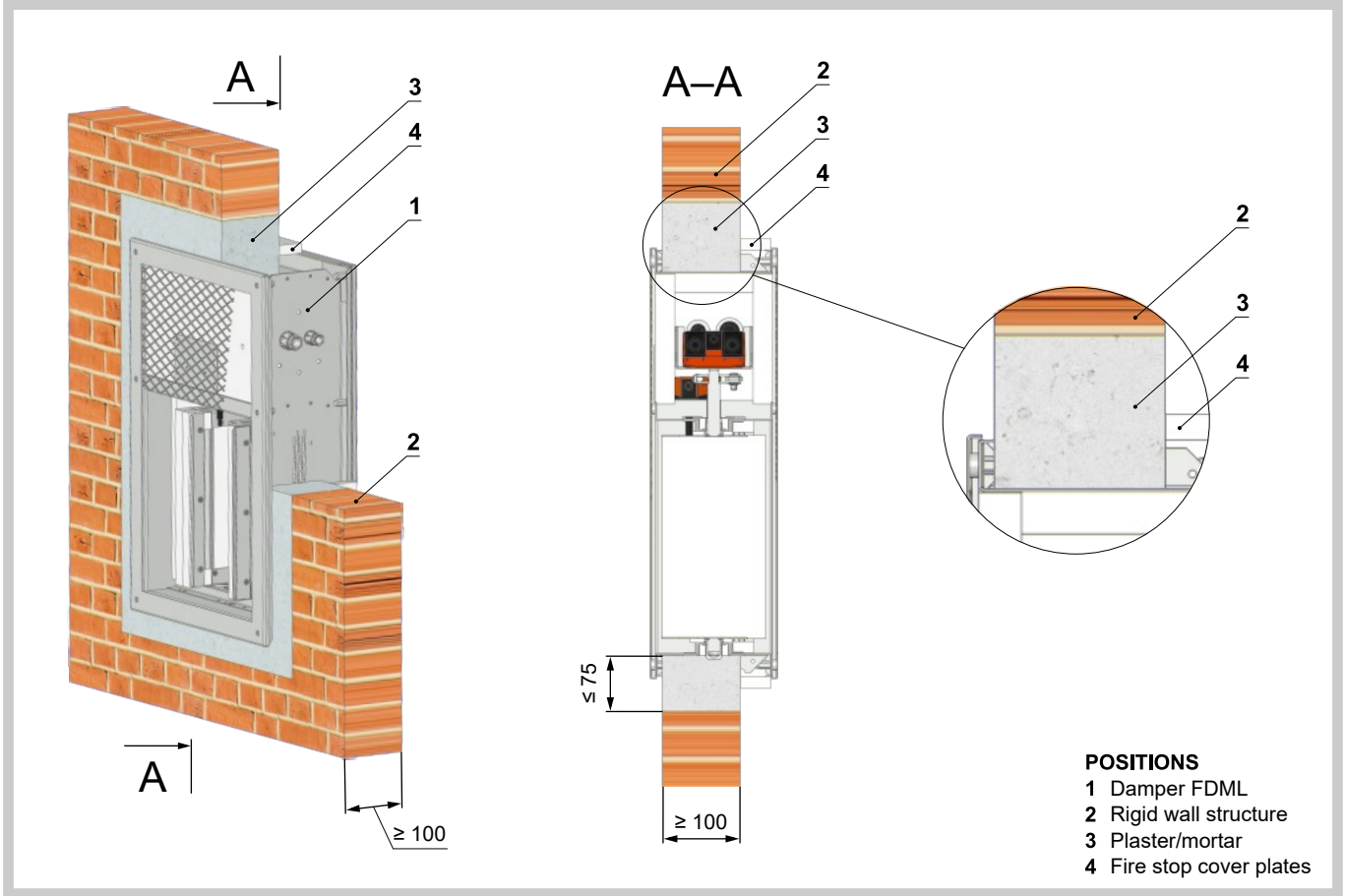

**Installation method into rigid wall structures - MINERAL WOOL - FIRE STOP SEALANT AND COATING**

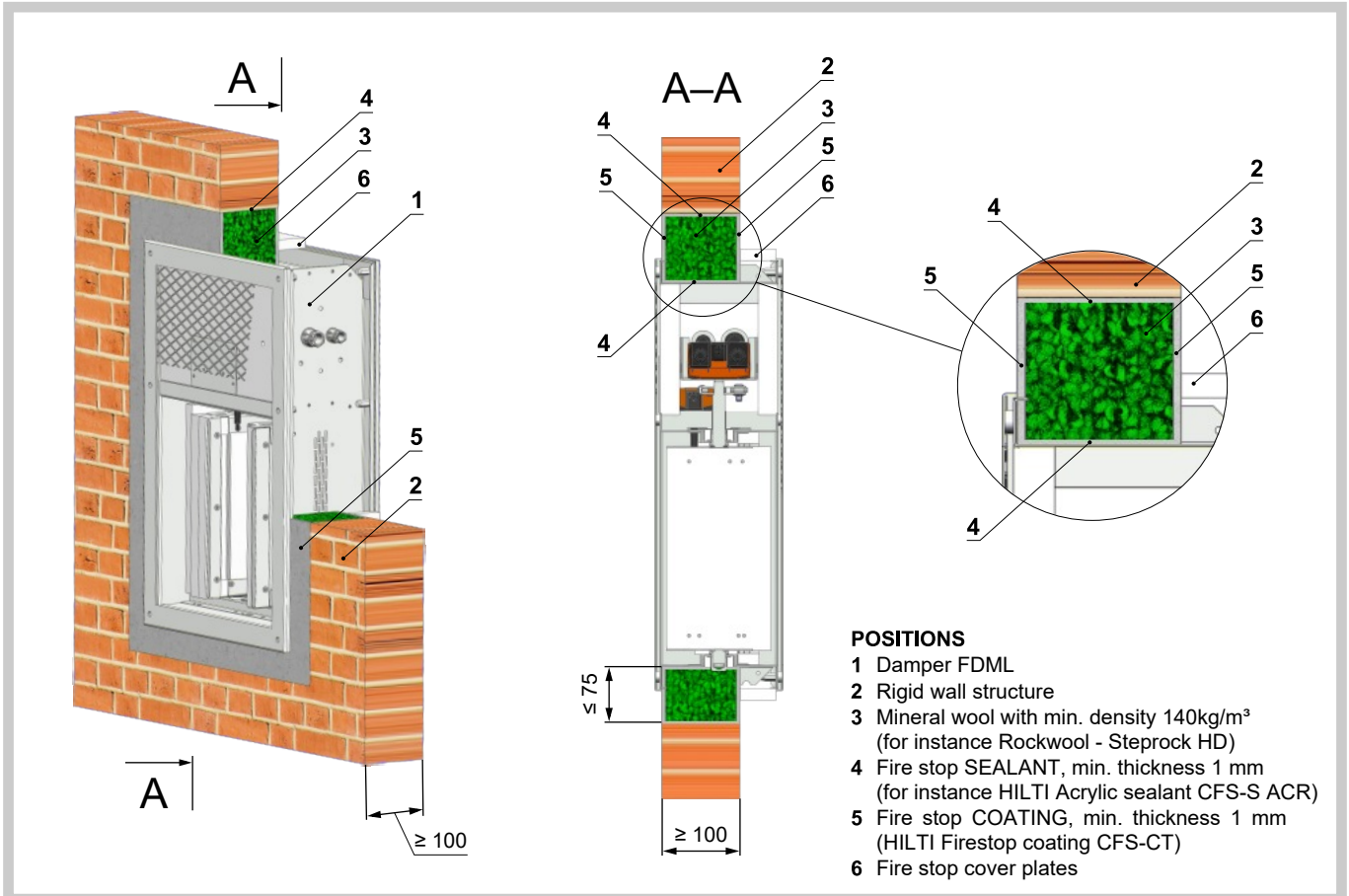

Examples of in-built fire dampers into plasterboard wall structures

Installation method into plasterboard wall structures - PLASTER - MORTAR

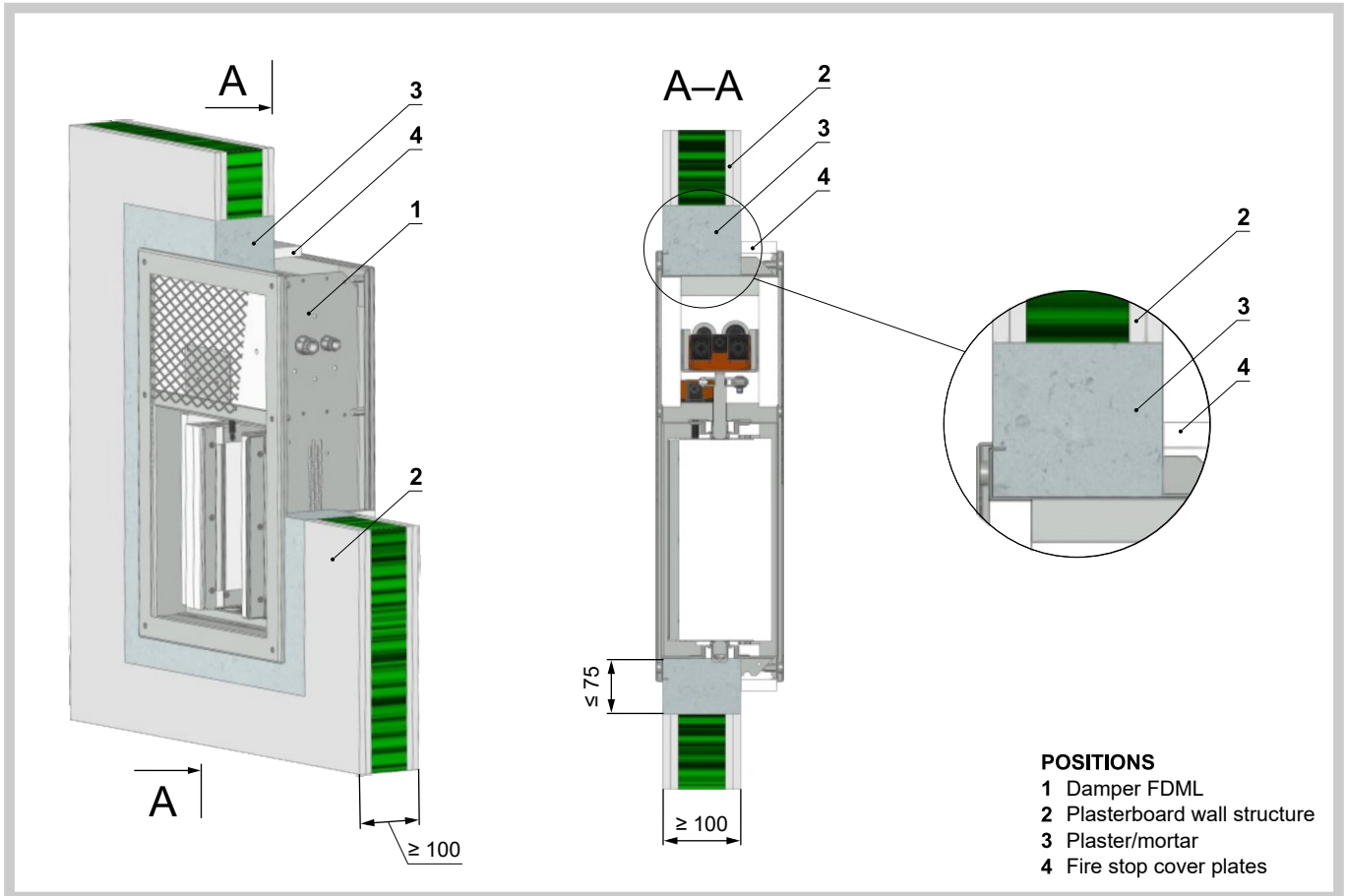

Installation method into plasterboard wall structures - MINERAL WOOL - FIRE STOP SEALANT AND COATING

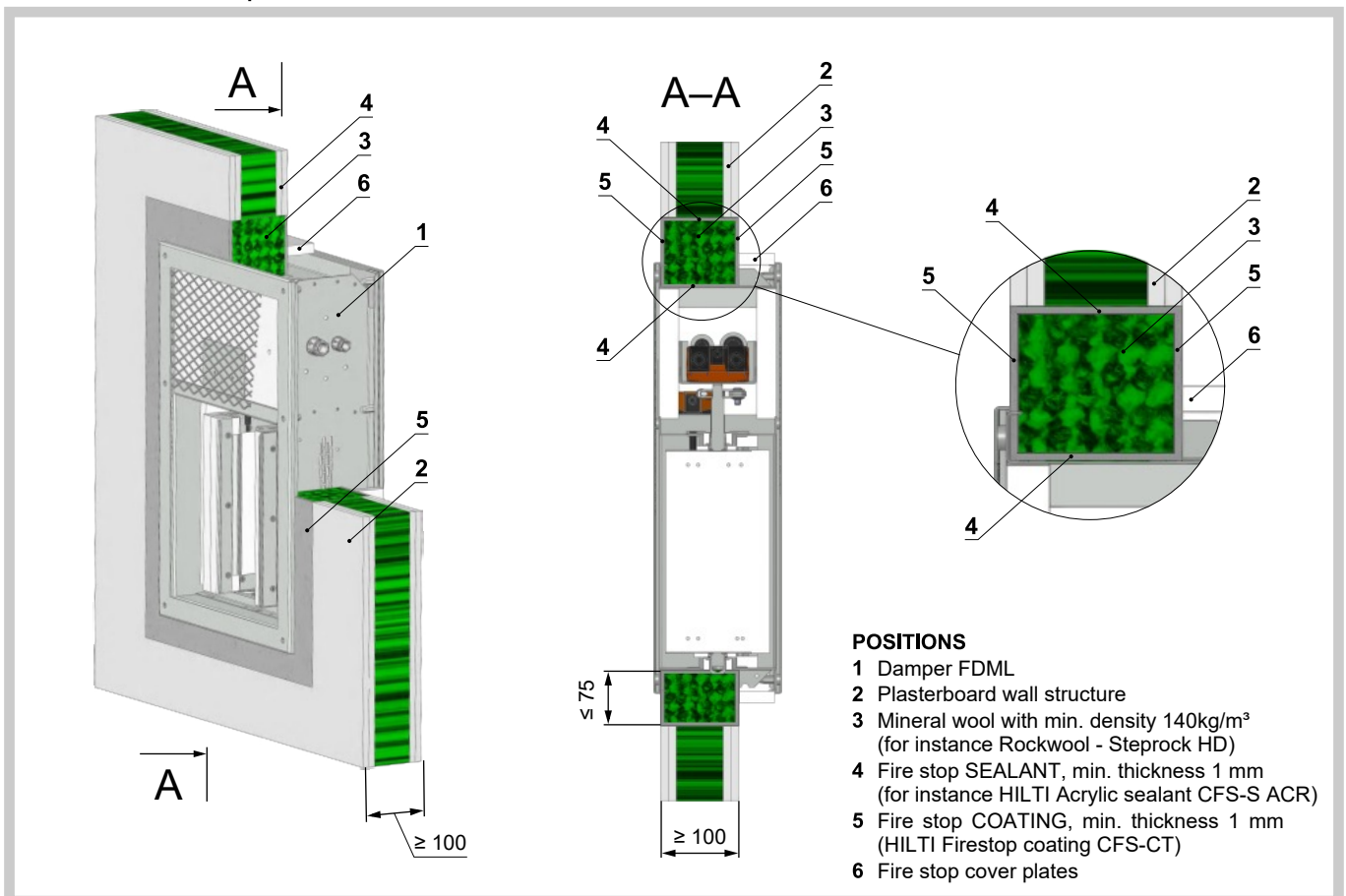



**Installation example with duct-work on both sides**

Installation method into rigid wall structure - PLASTER – MORTAR

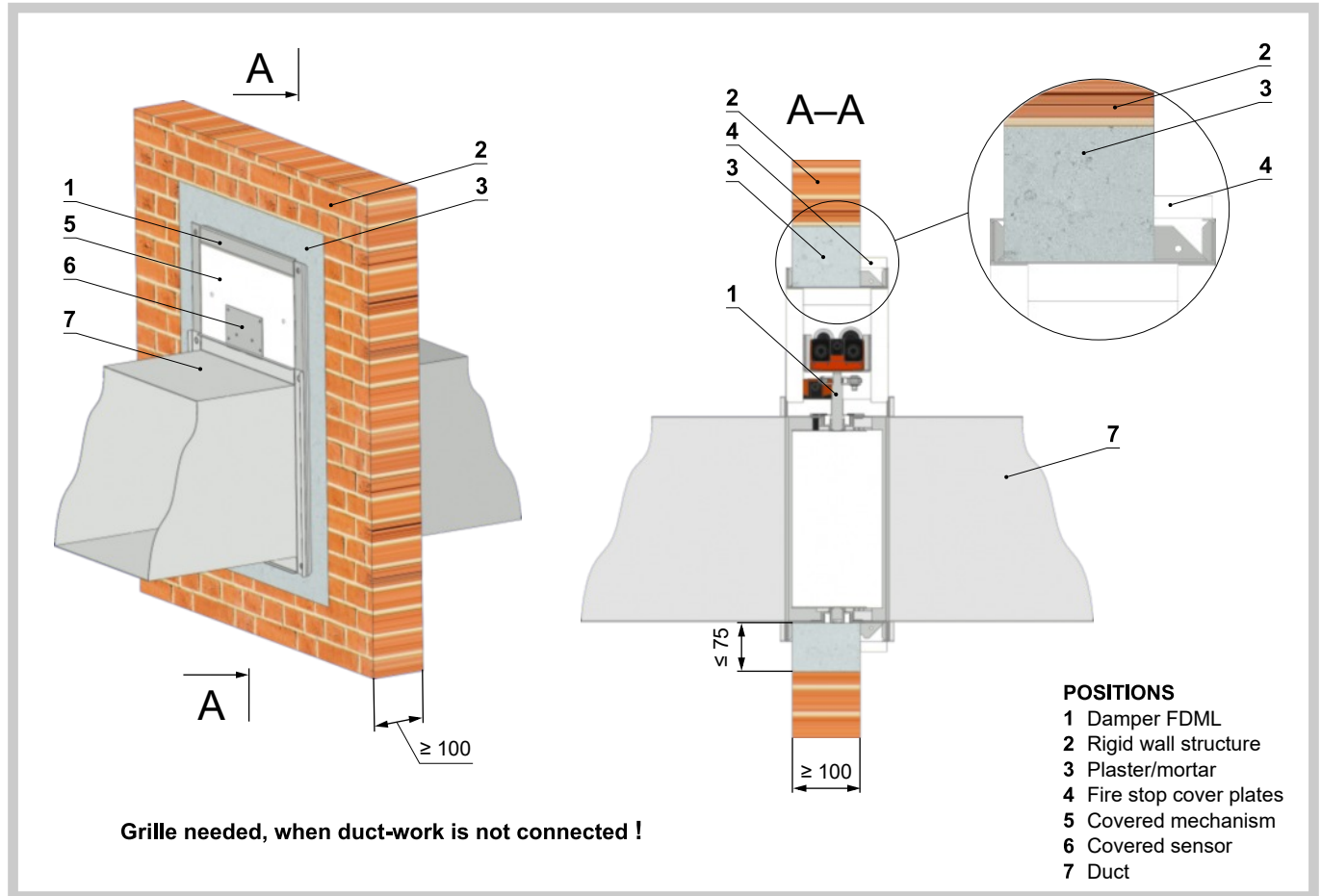

**Other examples of in-built situations**

**Rigid wall structure, wall thickness 150 mm**

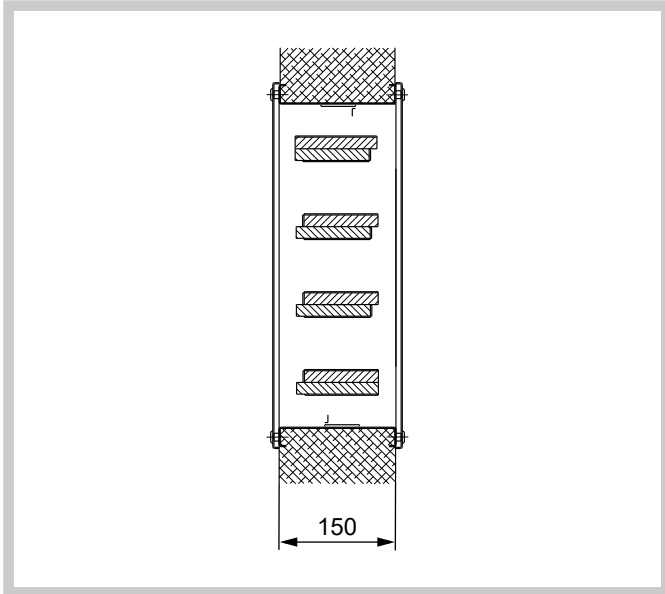

**Rigid wall structure, wall thickness >150 mm**

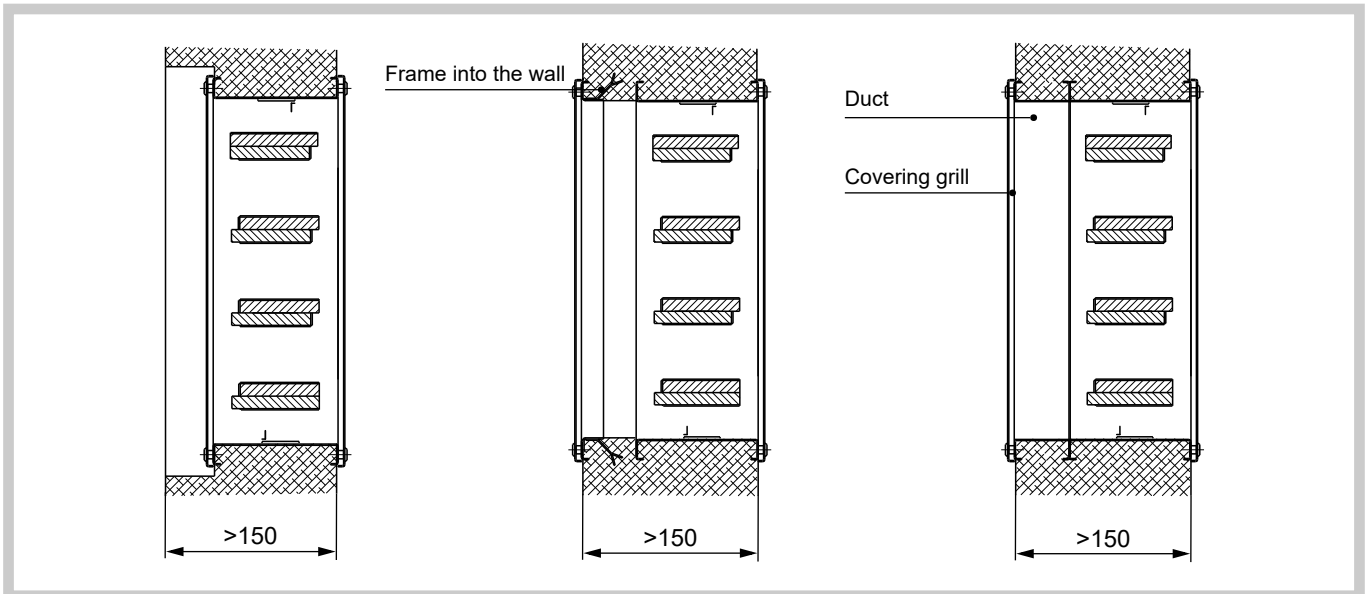

**Damper earth connection**

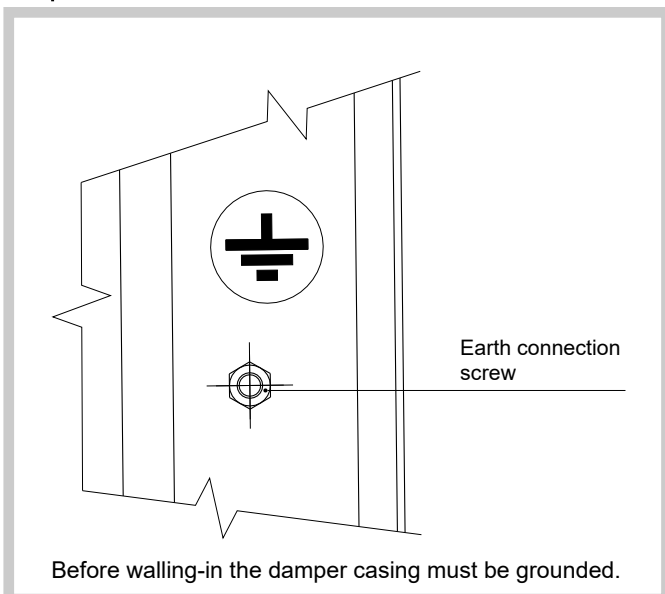

## ■ TECHNICAL DATA

### Pressure loss

#### Pressure loss calculation

$$\Delta p = \xi \cdot \rho \cdot \frac{w^2}{2}$$

$\Delta p$	[Pa]	pressure loss
$w$	[m.s <sup>-1</sup> ]	air flow speed in nominal damper section
$\rho$	[kg.m <sup>3</sup> ]	air density
$\xi$	[-]	coefficient of local pressure loss for the nominal damper section

### Coefficient of local pressure loss $\xi$

#### Coefficient of local pressure loss $\xi$

A	B																	
	300	315	355	400	450	500	560	600	630	650	700	710	750	800	850	900	950	1000
200	4,185	4,347	3,660	2,828	3,803	2,866	3,391	3,169	2,721	2,661	3,195	3,012	2,652	2,741	2,647	2,344	2,777	2,616
250	4,069	4,226	3,543	2,742	3,689	2,774	3,286	3,073	2,644	2,578	3,099	2,924	2,574	2,664	2,573	2,276	2,699	2,538
280	4,000	4,154	3,472	2,690	3,622	2,718	3,223	3,015	2,597	2,527	3,042	2,871	2,527	2,617	2,528	2,236	2,652	2,491
300	3,954	4,106	3,426	2,656	3,576	2,681	3,181	2,976	2,566	2,494	3,004	2,836	2,495	2,586	2,498	2,209	2,621	2,459
315	3,919	4,070	3,390	2,630	3,542	2,654	3,149	2,947	2,543	2,469	2,975	2,809	2,472	2,563	2,476	2,188	2,597	2,436
355	3,827	3,974	3,297	2,561	3,452	2,580	3,065	2,869	2,481	2,402	2,898	2,739	2,409	2,501	2,417	2,134	2,535	2,373
400	3,723	3,865	3,191	2,484	3,350	2,497	2,971	2,782	2,412	2,326	2,812	2,659	2,339	2,431	2,350	2,073	2,465	2,302
450	3,608	3,745	3,074	2,397	3,236	2,404	2,866	2,685	2,335	2,243	2,716	2,571	2,260	2,354	2,275	2,006	2,387	2,223
500	3,492	3,625	2,957	2,311	3,123	2,312	2,761	2,589	2,258	2,159	2,620	2,483	2,182	2,276	2,201	1,938	2,309	2,145
560	3,354	3,480	2,816	2,208	2,987	2,201	2,634	2,472	2,165	2,059	2,505	2,377	2,088	2,183	2,112	1,857	2,215	2,050
600	3,261	3,384	2,722	2,139	2,897	2,127	2,550	2,395	2,103	1,992	2,429	2,306	2,025	2,121	2,052	1,803	2,153	1,987
630	3,192	3,312	2,652	2,087	2,829	2,072	2,487	2,337	2,057	1,941	2,371	2,254	1,978	2,075	2,008	1,762	2,106	1,940
650	3,146	3,264	2,605	2,053	2,783	2,035	2,445	2,298	2,026	1,908	2,333	2,218	1,947	2,044	1,978	1,735	2,074	1,909
700	3,031	3,144	2,488	1,967	2,670	1,942	2,340	2,201	1,949	1,824	2,237	2,130	1,869	1,967	1,904	1,668	1,996	1,830
710	3,007	3,119	2,464	1,949	2,648	1,924	2,319	2,182	1,933	1,808	2,218	2,112	1,853	1,951	1,889	1,654	1,981	1,814
750	2,915	3,023	2,370	1,880	2,557	1,850	2,235	2,105	1,871	1,741	2,141	2,042	1,790	1,889	1,830	1,600	1,918	1,751
800	2,800	2,903	2,253	1,794	2,444	1,758	2,130	2,008	1,794	1,657	2,045	1,954	1,712	1,812	1,755	1,532	1,840	1,673
850	2,684	2,783	2,136	1,708	2,330	1,665	2,025	1,911	1,717	1,573	1,949	1,865	1,634	1,734	1,681	1,465	1,762	1,594
900	2,569	2,662	2,019	1,622	2,217	1,573	1,920	1,814	1,640	1,489	1,853	1,777	1,555	1,657	1,607	1,397	1,684	1,516
950	2,453	2,542	1,901	1,536	2,104	1,480	1,815	1,717	1,563	1,406	1,758	1,689	1,477	1,579	1,532	1,330	1,606	1,437
1000	2,338	2,422	1,784	1,450	1,991	1,388	1,710	1,621	1,485	1,322	1,662	1,601	1,399	1,502	1,458	1,262	1,528	1,358

## ■ MATERIAL, FINISHING

### Material

Damper frame is made from galvanized sheet metal.

Covering protection grills (similar to type KMM) are produced from sheet iron and coated with baking varnish in colour RAL 9010. Requirements for other colours must be discussed with manufacturer in advance.

Damper blades are made from asbestos-free fire protective plates from mineral fibres.

Closing mechanism is zinc-coated. Coupling elements are zinc-coated.

### **According to the customer request, the damper can be made of stainless steel.**

#### Specifications for stainless-steel models – classification of stainless steel:

- Class A2 – Food-grade stainless steel (AISI 304 – EN 17240)
- Class A4 – Chemistry-grade stainless steel (AISI 316, 316L – EN 17346, 17349)

The respective stainless steel is the material for all components present or accessing the damper interior; components outside the damper body are typically from galvanized sheet metal (fasteners for mounting the servo drive or mechanics, mechanics components except Item 4), frame components.

#### The following components, including the fasteners, are made from stainless steel at all times:

- 1) Damper body and all components permanently attached
- 2) Leaf holders, including pins, metal parts of leaf
- 3) Control components inside the damper (leaf angle selector, pin with lever)
- 4) Mechanical components entering the interior of damper body (lower sheet of mechanics, lock holder "1", lock lever "2", lock spring, 8 dia. stopper pin, mechanics pin)
- 5) Inspection hole cover including the clip and fasteners (if they are parts of the cover)
- 6) Bearing for torque transfer from the lever with pin on the angle selector at the leaf (made from AISI 440C)

The leaf of the damper is made from two Promatect-H sheets, thickness 20 mm, connected with galvanized nailed "U" connectors which are sealed with Promat K84 from the outside; Promaseal tape is attached to the leaves with stainless-steel nailed "U" connectors.

Plastic, rubber and silicon components, sealants, foaming bands, glass-ceramic seals, housings, brass bearings of the leaf, servo drives, and end switches are identical for all material variants of the dampers.

The thermal link is identical for all material variants of the dampers. Upon specification by customer, the thermal link may be made from A4 from stainless steel sheet metal.

The temperature-dependent initiator of the servo drive (sensor) is modified for stainless-steel variants of the dampers; the standard galvanized screws are replaced with stainless-steel M4 screws of corresponding class the counterpart has stainless-steel riveting M4 nuts.

Some fasteners and components are available in one class of stainless steel; the type will be used in all stainless-steel variants.

The leaf in the variants for chemical environments (Class A4) is always treated with a coating of chemically resistant Promat SR.

Any other requirements for the design shall be considered atypical and shall be addressed on an individual basis.

## ■ CHECKS, TESTS

### Checks

Dimensions are checked using common gauges according to the standards for not tolerated dimensions applied in air conditioning sector. In-process inspections of parts and main dimensions are carried out according to drawing documentation.

### Testing

After workshop assembly 100% functional test of closing device and electric elements is carried out.

## ■ PACKAGING, TRANSPORT, ACCEPTANCE, STORAGE

### Logistic data

Dampers are transported in bulk in covered transport means without direct weathering effects, without strong impacts and ambient temperature must not exceed +50°C. If customer requires other packaging it will not be returnable and price of such a packaging is not included in the price.

Dampers shall be considered as accepted unless it is specified otherwise in particular order.

During handling within transport and storage dampers must be protected from mechanical damage. Dampers must be stored in roofed objects with environment without aggressive vapours, gases and dust. Temperature scope in such objects must be within - 5 to + 40°C and relative humidity max. 80 %.

The delivery means complete Multi blade fire damper and warranty card with inspection stamp (warranty card is attached to invoice).

### Guarantee

Manufacturer provides 24 month-guarantee from dispatching date.

Guarantee for FDML damper provided by the manufacturer becomes void if any non professional handling with closing mechanism and control device by not trained persons has been performed, after dismantling electrical elements, i.e. limit switches, servo drives, optical smoke detectors and thermo-electric actuators. Guarantee also becomes void when damper is used for other than intended use and in working conditions not allowed by this standard or if it was damaged mechanically during handling.

If any damage occurs during the transport it is necessary to make a report during unloading with transport company for future claims.

## ■ ASSEMBLY, OPERATION AND SERVICEABILITY CHECKS

### Assembly

Assembly, maintenance and serviceability checks may be performed only by persons capable for such activities, i.e. "AUTHORIZED PERSONS" trained by the manufacturer. Training is organised and carried out by MANDÍK, a.s. who issues "CERTIFICATE" on professional qualification with validity 5 years and its prolongation must be provided by "AUTHORIZED PERSON" itself directly at trainer premises.

When terminates validity of the CERTIFICATE such CERTIFICATE becomes void and it is discarded from trainer files.

Only qualified persons can be trained who then answer for performed works.

Damper must be installed with respecting of all safety standards and regulations.

Closing mechanism and blade seating faces must be protected from clogging to ensure reliable functioning of the damper.

### Putting into operation and serviceability checks

Before putting the damper into operation serviceability checks and functional tests must be carried out including testing of functionality of all electrical elements. After putting into operation these serviceability checks must be carried out 2 times a year at least. If no defect is found during two subsequent serviceability checks, it is possible to carry out such operational checks once a year.

If dampers are found as non-functional due to any reason, they must be clearly marked. User is obliged to ensure that the damper is put in conditions in which it is able to fulfil its function and before this user must ensure fire protection in some other sufficient way. Results of regular inspections and checks, found deficiencies and all important facts related to functioning of the damper must be recorded in the FIRE JOURNAL and reported to user immediately.

Before putting damper into serviceable condition after assembly and subsequent serviceability checks the following inspections must be carried out:

- Visual check of correct walling-in of the damper, thermal fuse, closing mechanisms and blade seating faces.

Functionality of closing mechanism is done as follows:

- Press reset button on the thermo-electric actuator accessible through the hole in cover plate and check dislocation of blade to the position "CLOSED" and signalling of positions "OPEN -CLOSED".

Serviceability checks of optical smoke detector are performed by manufacturer or authorized company staff with relevant electro-technical qualification and who were demonstrably trained by the manufacturer. Serviceability checks of detectors are carried out within serviceability checks of fire dampers min. once a year.

### Spare parts

Spare parts are supplied only on the basis of orders.

■ PRODUCT DATA

Nameplate

Nameplate is attached to damper casing

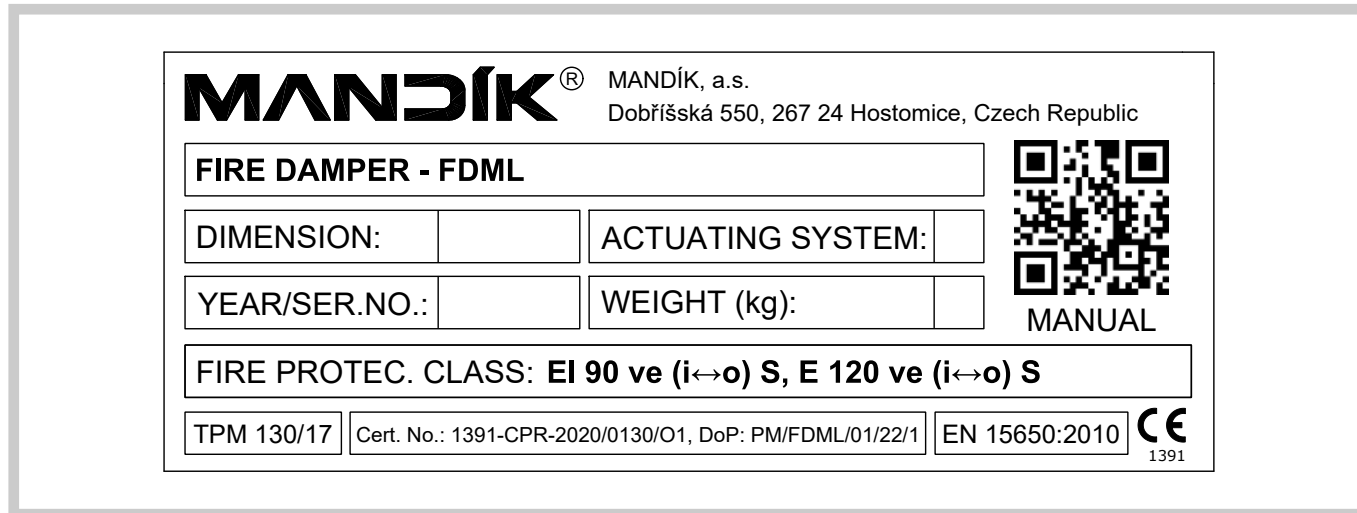

■ ORDER KEY

FDML 300x400-.40 A TPM 130/17

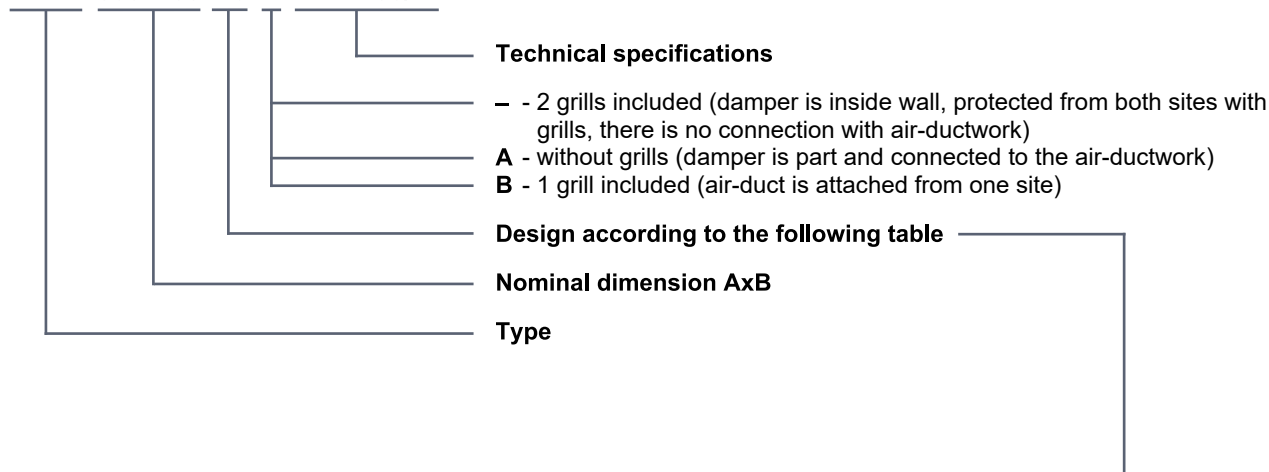

Damper design	Additional Nr.
with servo drive Belimo or Gruner ( 230V AC) with thermo-electric actuator	.40
with servo drive Belimo or Gruner (24V AC/DC) with thermo-electric actuator with optical smoke detector ORS 142K and supply unit ZPN-10-24 (assembly voltage 230V AC)*	.41
with servo drive Belimo or Gruner (24V AC/DC) with thermo-electric actuator	.50
with servo drive Belimo or Gruner (24V AC/DC) with thermo-electric actuator with optical smoke detector ORS 142K (assembly voltage 24V DC)*	.51

\*Optical smoke detectors ORS 142K and supply unit ZPN-10-24 are in bulk

MANDÍK, a.s.  
Dobříšská 550  
26724 Hostomice  
Czech Republic  
Tel.: +420 311 706 706  
E-Mail: [mandik@mandik.cz](mailto:mandik@mandik.cz)  
[www.mandik.com](http://www.mandik.com)

---

The producer reserves the right for innovations of the product. For actual product information see  
[www.mandik.com](http://www.mandik.com)