

Original instructions  
**Arden 3500**

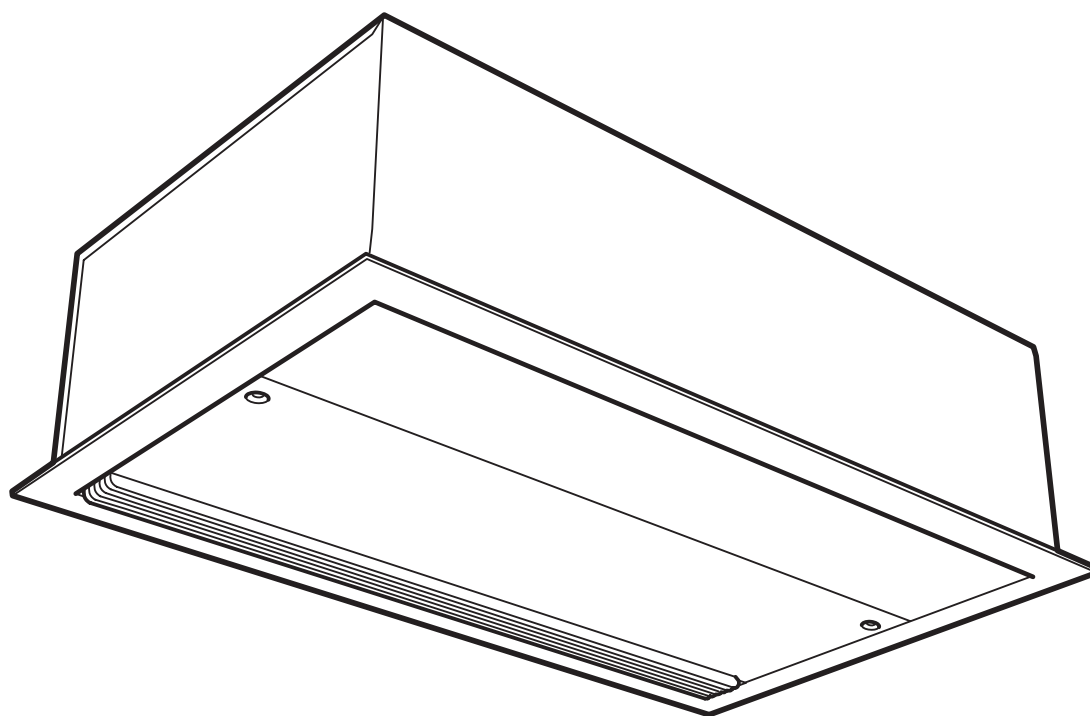

EN .... 13

SE ... 17

NO ... 22

FR ... 27

DE ... 33

NL ...39

ES ... 45

IT ... 51

PL ... 57

RU ... 63

FI ... 69

DK ... 74

## Arden 3500

- EN** The introduction pages consist mainly of pictures. For translation of the English texts used, see the respective language pages.
- SE** Introduktionssidorna består huvudsakligen av bilder. För översättning av de engelska texter som används, se respektive språksidor.
- NO** Introduksjonssidene består hovedsakelig av bilder. For oversettelse av de engelske tekstene, se de respektive språksidene
- FR** Les pages de présentation contiennent principalement des images. Consulter la page correspondant à la langue souhaitée.
- DE** Die Einleitungsseiten bestehen hauptsächlich aus Bildern. Für die Übersetzung der verwendeten Texte in englischer Sprache, siehe die entsprechenden Sprachseiten.
- NL** De inleidende pagina's bevatten hoofdzakelijk afbeeldingen. Voor een vertaling van de gebruikte Engelse teksten, zie de pagina's van de resp. taal.
- ES** Las páginas introductorias contienen básicamente imágenes. Consulte la traducción de los textos en inglés que las acompañan en las páginas del idioma correspondiente.
- IT** Le pagine introduttive contengono prevalentemente immagini. Per le traduzioni dei testi scritti in inglese, vedere le pagine nelle diverse lingue.
- PL** Początkowe strony zawierają głównie rysunki. Tłumaczenie wykorzystanych tekstów angielskich znajduje się na odpowiednich stronach językowych.
- RU** Страницы в начале Инструкции состоят в основном из рисунков, схем и таблиц. Перевод встречающегося там текста приведен в разделе RU.
- FI** Esittelysivut koostuvat lähinnä kuvista. Suvuilla olevien enlanninkielisten sanojen käännökset löytyvät ko. kielisivuilta.
- DK** Introduktionssiderne består hovedsageligt af billeder. For oversættelse af de engelske tekster, se siderne for de respektive sprog.

# Arden 3500

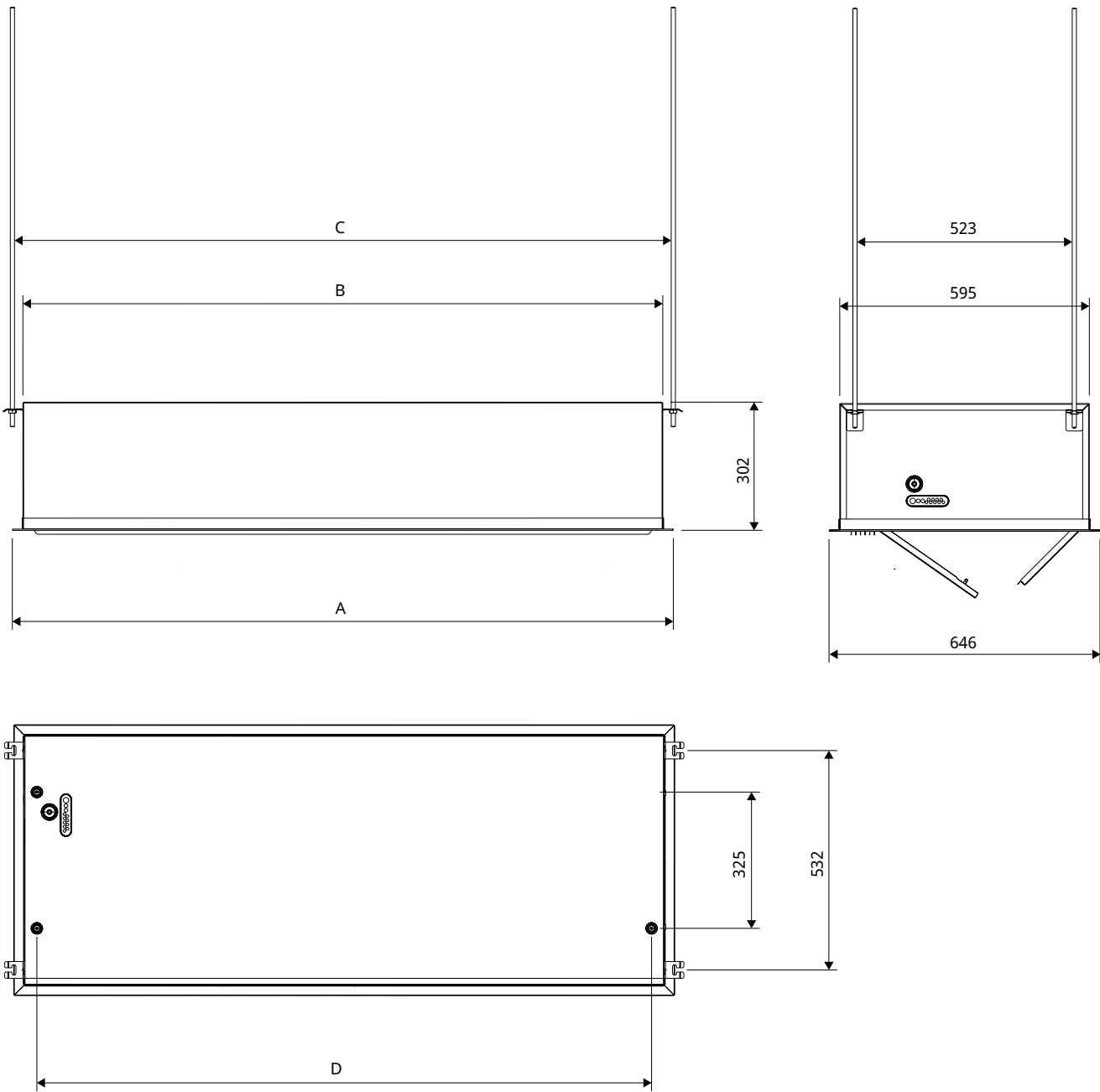

Type	A [mm]	B [mm]	C [mm]	D [mm]
ARFEC3510	1057	1016	1067	956
ARFEC3515	1567	1526	1577	1466
ARFEC3520	2073	2031	2083	1971

# Arden 3500

## Mounting

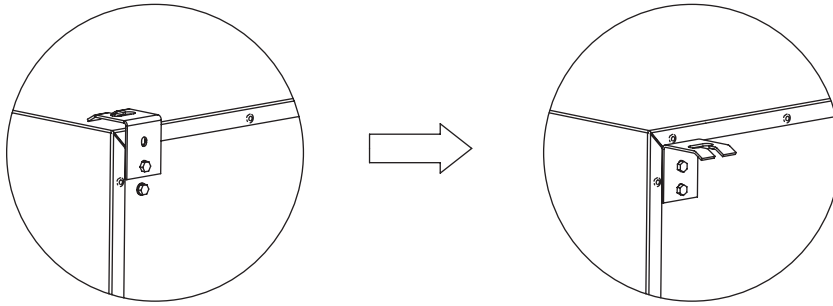

Fig. 1a: Mounting brackets on delivery.

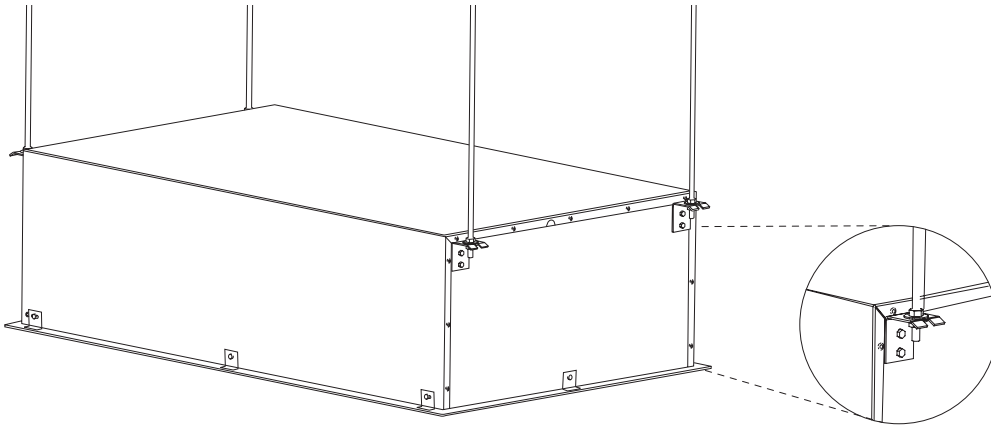

Fig. 1b: Mounting on threaded bars outside the unit.

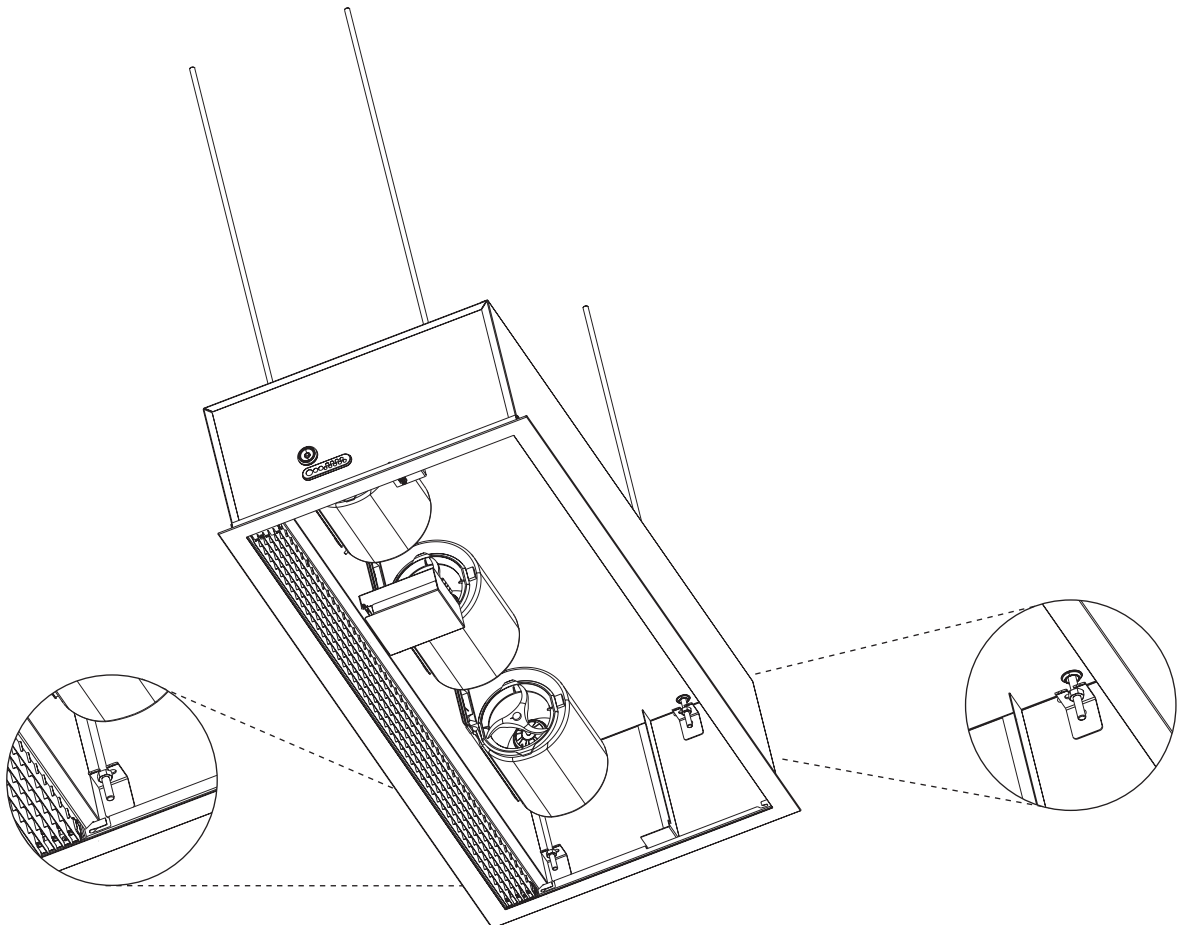

Fig. 2: Mounting on threaded bars inside the unit. Note that the brackets are placed at different heights and therefore threaded rods should be of different lengths.

# Arden 3500

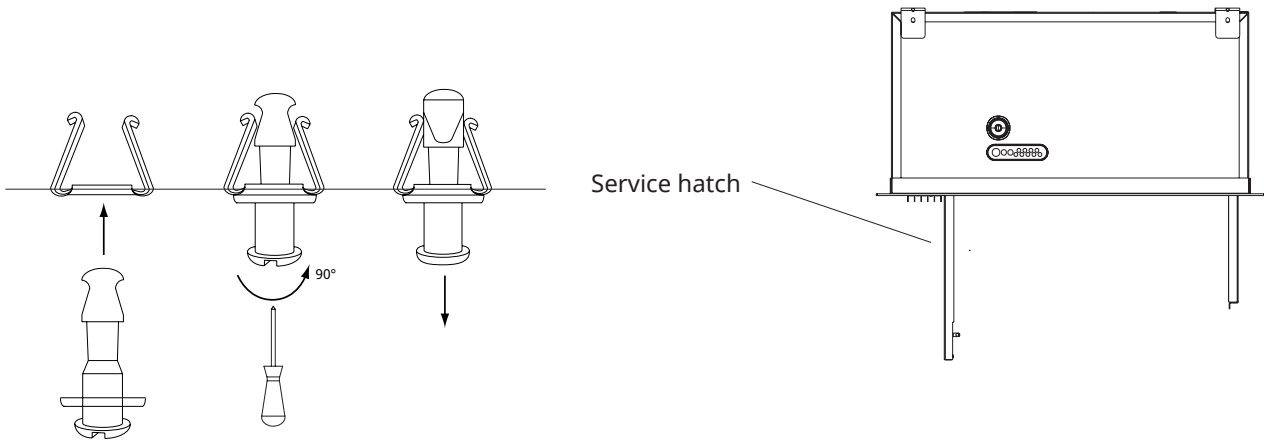

Fig. 3: Snap fixings

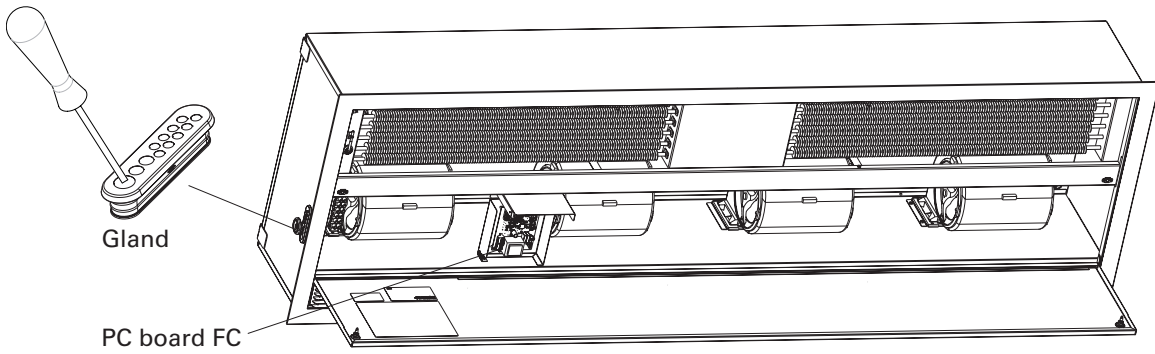

Fig. 4: PC board FC is integrated within the air curtain at delivery.

## Water connections

DN20 (3/4''), inside thread

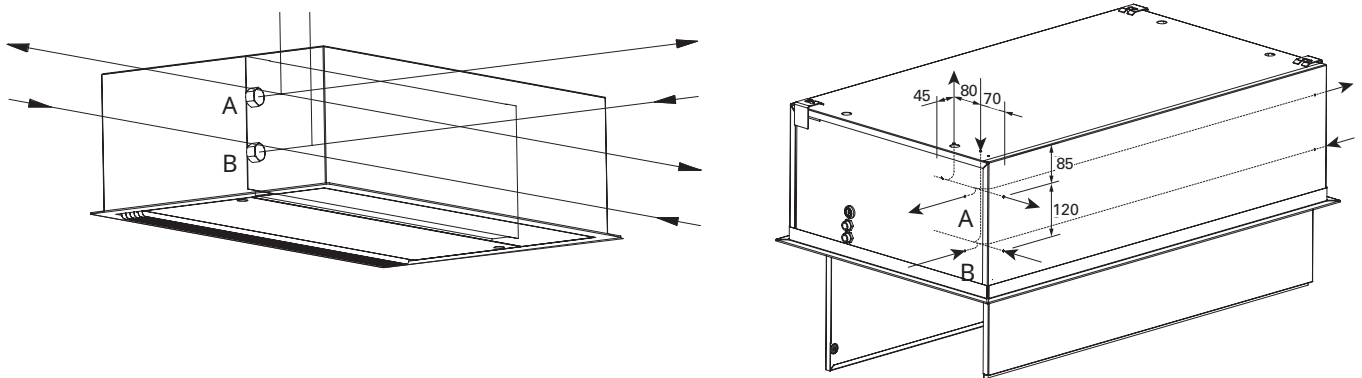

Fig. 5: The water coil is connected inside the unit through holes which are made (during installation) on the top or the side of the unit, possible places are marked with punch marks.

# Arden 3500

## Accessories



PA34TR



PA34CB



PA34VD

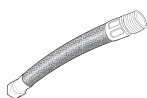

FH1020



DTV200S

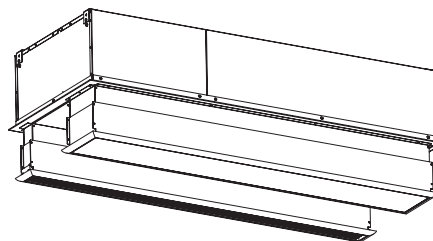

AR35XTT

Item number	Type		Consists of	Dimensions
18056	<b>PA34TR15*</b>	ARFEC3510/3515	4 pcs	L: 1 m
18057	<b>PA34TR20*</b>	ARFEC3520	6 pcs	L: 1 m
18059	<b>PA34CB15*</b>	ARFEC3510/3515	4 pcs	
18060	<b>PA34CB20*</b>	ARFEC3520	6 pcs	
18065	<b>PA34VD15*</b>	ARFEC3510/3515	4 pcs	
18066	<b>PA34VD20*</b>	ARFEC3520	6 pcs	
237568	<b>FH1020</b>	ARFEC3500W	2 pcs	L: 1 m
17597	<b>DTV200S*</b>	ARFEC3500W		
19070	<b>AR35XTT10*</b>	ARFEC3510		H: 130-210 mm
19071	<b>AR35XTT15*</b>	ARFEC3515		H: 130-210 mm
19072	<b>AR35XTT20*</b>	ARFEC3520		H: 130-210 mm

\*) See separate manual.

## Valve systems

Item number	Type	DN	Flow range [l/s]
238293	<b>VPFC15LF</b>	DN15	0,012-0,068
238294	<b>VPFC15NF</b>	DN15	0,024-0,13
238295	<b>VPFC20</b>	DN20	0,058-0,32
238296	<b>VPFC25</b>	DN25	0,10-0,60
238297	<b>VPFC32</b>	DN32	0,22-1,03

See separate manual.

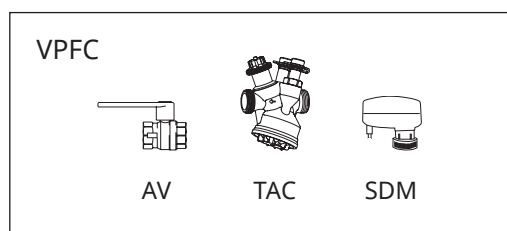

## Control systems

The air curtain must be supplemented with a control system.

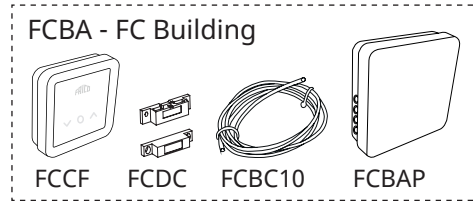
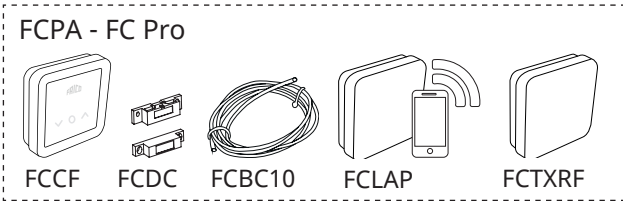
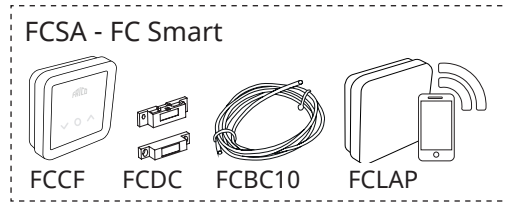
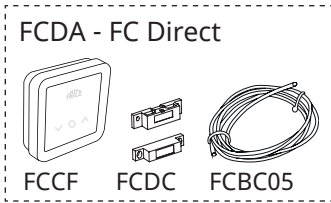

Item number	Type	Name	Dimensions
74684	<b>FCDA</b>	FC Direct	89x89x26 mm (FCCF)
74685	<b>FCSA</b>	FC Smart	89x89x26 mm (FCCF)
74686	<b>FCPA</b>	FC Pro	89x89x26 mm (FCCF)
74687	<b>FCBA</b>	FC Building	89x89x26 mm (FCCF)

## Accessories

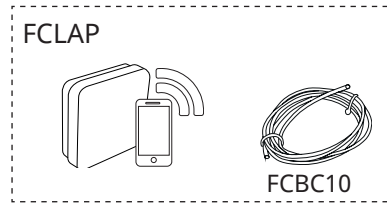
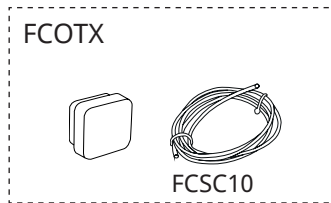
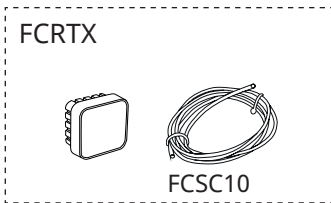

Item number	Type	Dimensions
74694	<b>FCRTX</b>	39x39x23 mm
74695	<b>FCOTX</b>	39x39x23 mm
74699	<b>FCLAP</b>	89x89x26 mm
74702	<b>FCWTA</b>	for water heated units
17495	<b>FCDC</b>	
74718	<b>FCBC05</b>	5 m
74719	<b>FCBC10</b>	10 m
74720	<b>FCBC25</b>	25 m
74721	<b>FCSC10</b>	10 m
74722	<b>FCSC25</b>	25 m
74703	<b>FCTXRF</b>	for FC Smart, FC Pro 89x89x26 mm

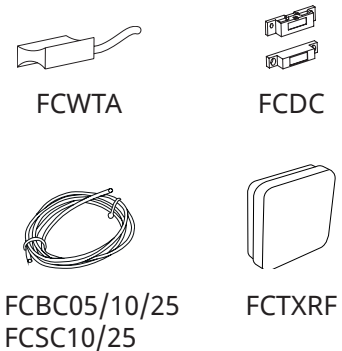

See separate manual for FC.

ARFEC3500 A

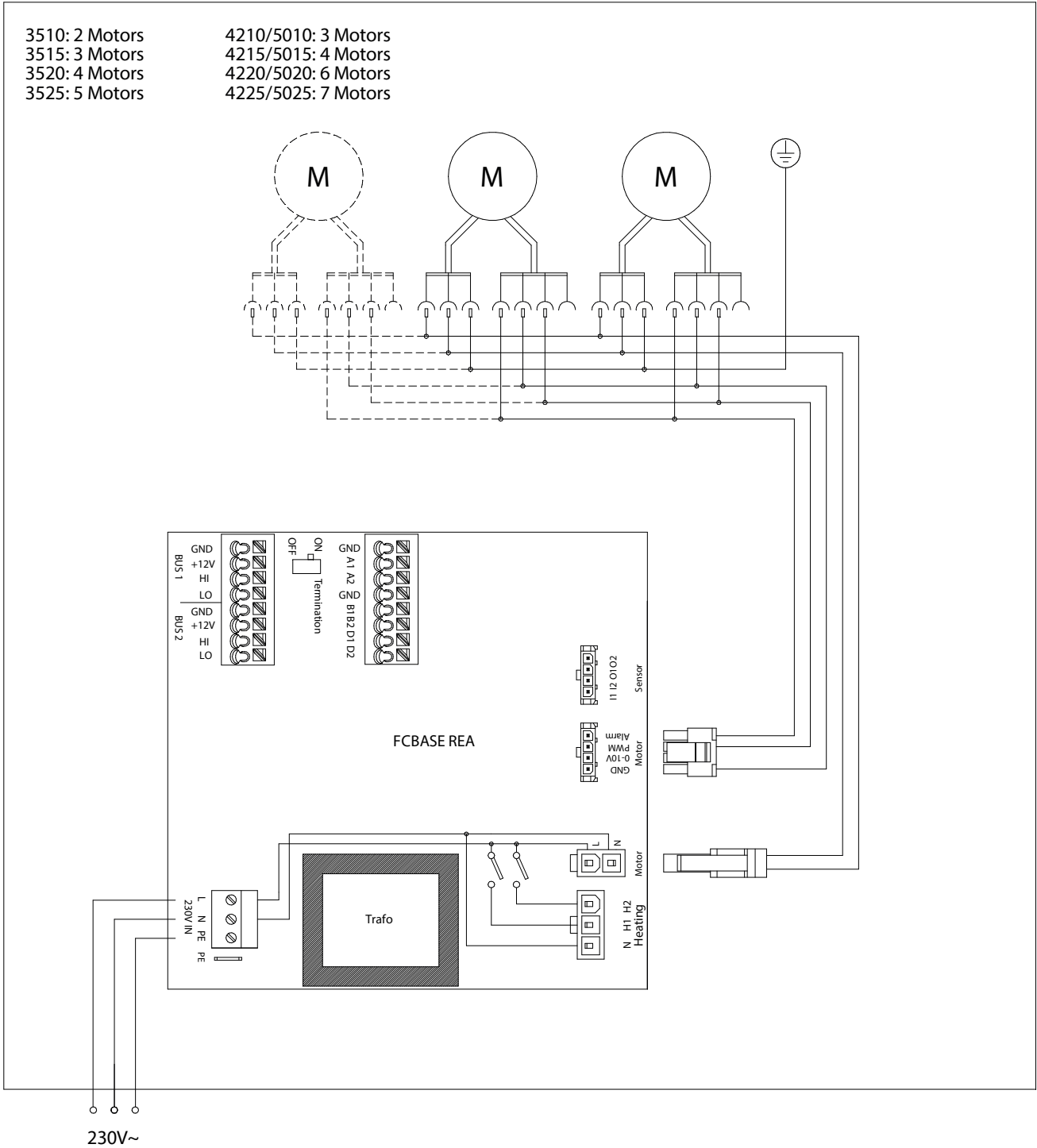

Wiring diagrams for control system in the FC manual.



ARFEC3510/3515 E

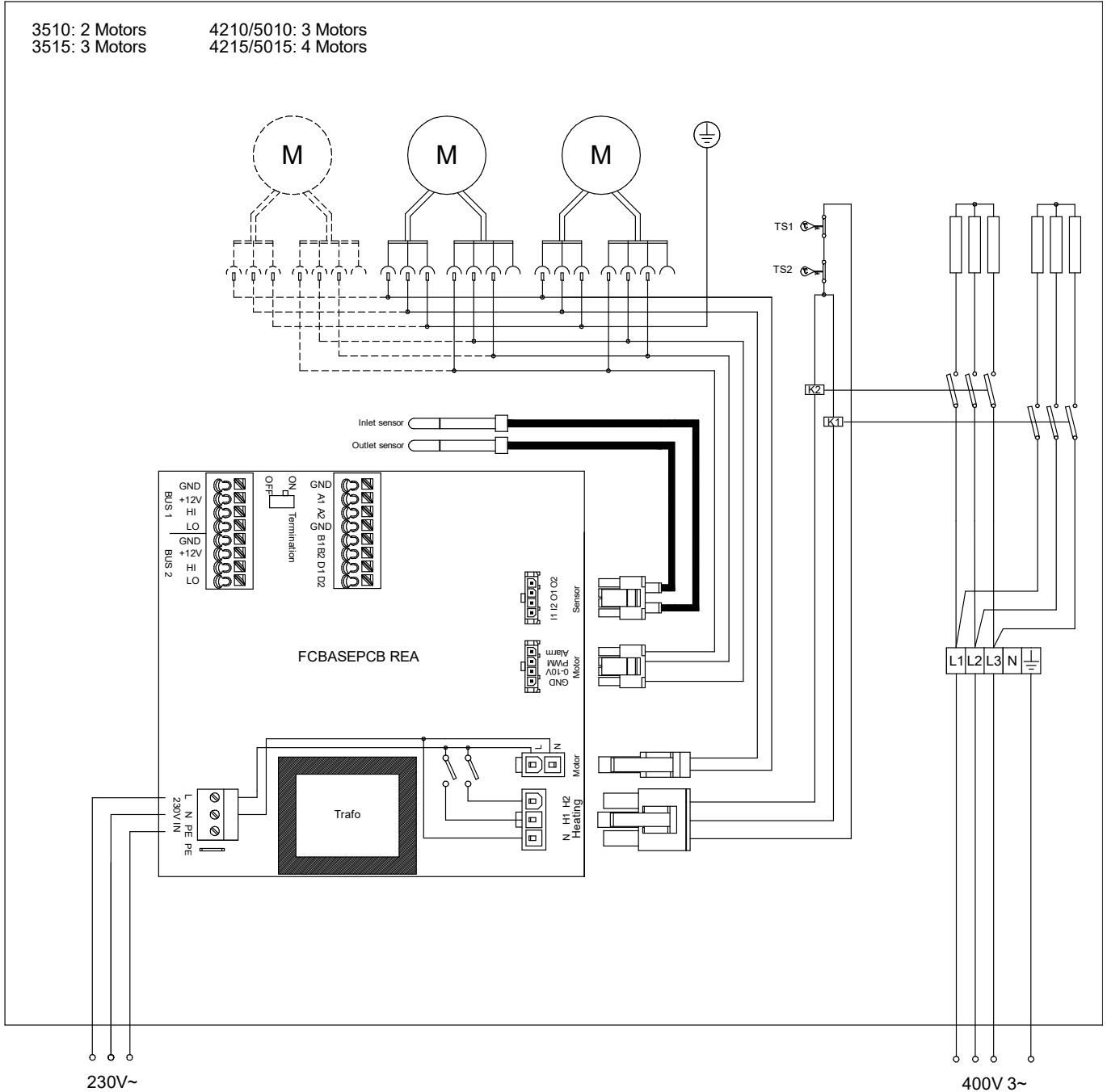

Wiring diagrams for control system in the FC manual.

ARFEC3520 E

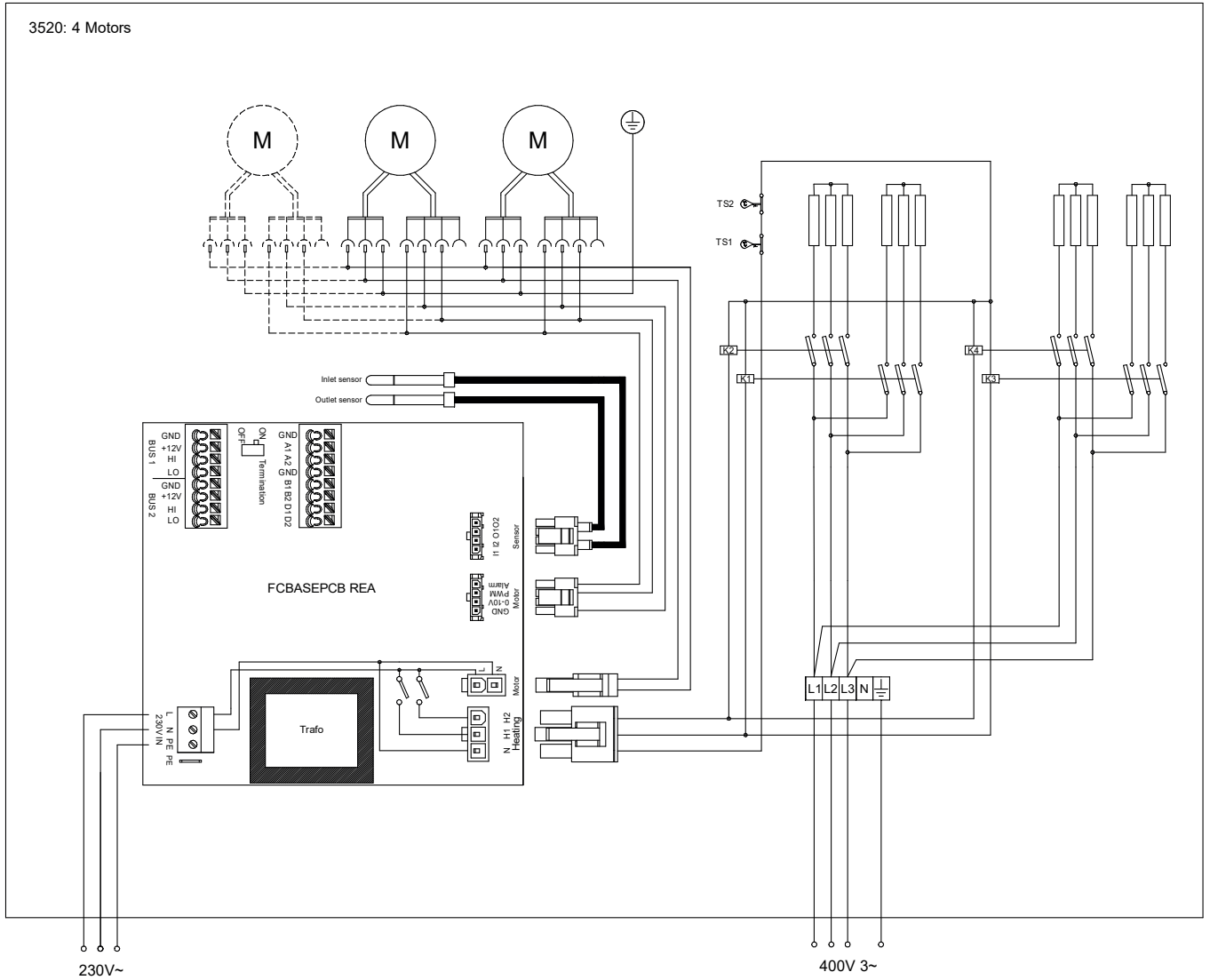

Wiring diagrams for control system in the FC manual.

ARFEC3500 W

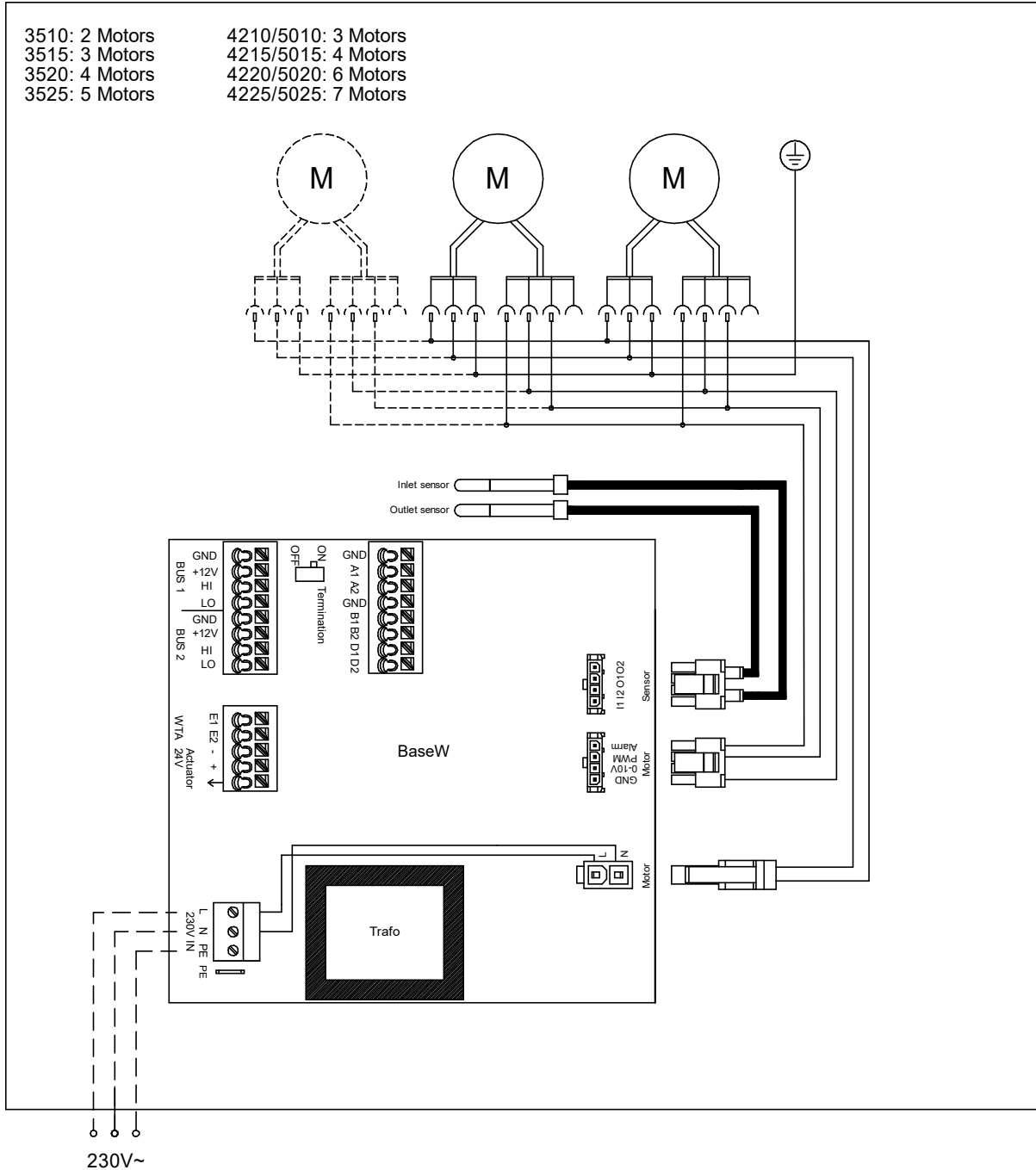

Wiring diagrams for control system in the FC manual.

Technical specifications

Voltage motor: 230V~

✿ Ambient, no heat - ARFEC3500 A (IP20)

Item number	Type	Output [kW]	Airflow*1 [m³/h]	Sound power*2 [dB(A)]	Sound pressure*3 [dB(A)]	Motor [W]	Amperage motor [A]	Weight [kg]
190544	ARFEC3510A	0	1000/1900	76	43/60	340	2,3	35
190548	ARFEC3515A	0	1550/3000	78	44/62	510	3,2	49
190552	ARFEC3520A	0	2250/3800	79	45/63	670	4,1	60

⚡ Electrical heat - ARFEC3500 E (IP20)

Item number	Type	Output steps [kW]	Airflow*1 [m³/h]	$\Delta t^4$ [°C]	Sound power*2 [dB(A)]	Sound pressure*3 [dB(A)]	Motor [W]	Amperage motor [A]	Voltage [V] Amperage [A](heat)	Weight [kg]
190545	ARFEC3510E09	4,5/9,0	1000/1900	26/14	76	43/60	340	2,3	400V3~/13	35
190549	ARFEC3515E14	6,8/14	1550/3000	26/13	77	44/62	510	3,2	400V3~/19,5	53
190553	ARFEC3520E18	9,0/18	2250/3800	24/14	78	45/63	670	4,1	400V3~/26	65

💧 Water heat - ARFEC3500 W (IP20)

Item number	Type	Output*5 [kW]	Airflow*1 [m³/h]	$\Delta t^{4,5}$ [°C]	Water volume [l]	Sound power*2 [dB(A)]	Sound pressure*3 [dB(A)]	Motor [W]	Amperage motor [A]	Weight [kg]
190546	ARFEC3510W	8,3	1000/1900	16/13	1,3	75	43/59	340	2,3	39
190550	ARFEC3515W	12	1500/2800	16/13	2,1	76	43/60	510	3,2	55
190554	ARFEC3520W	17	2100/3700	17/14	2,9	77	45/61	670	4,2	70

💧 Water heat - ARFEC3500 WLL (IP20)

Item number	Type	Output*6 [kW]	Airflow*1 [m³/h]	$\Delta t^{4,6}$ [°C]	Water volume [l]	Sound power*2 [dB(A)]	Sound pressure*3 [dB(A)]	Motor [W]	Amperage motor [A]	Weight [kg]
190547	ARFEC3510WLL	8,0	1000/1900	14/12	2,6	75	43/59	340	2,3	42
190551	ARFEC3515WLL	12	1500/2800	15/13	4,2	76	43/60	510	3,2	58
190555	ARFEC3520WLL	16	2100/3700	15/13	5,8	77	45/61	680	4,2	73

\*1) Low/high airflow (2/10V)

\*2) Sound power ( $L_{WA}$ ) measurements according to ISO 27327-2: 2014, Installation type E.

\*3) Sound pressure ( $L_{pA}$ ). Conditions: Distance to the unit 5 metres. Directional factor: 2. Equivalent absorption area: 200 m². At low/high airflow (2/10V).

\*4)  $\Delta t$  = temperature rise of passing air at maximum heat output and low/high airflow (2/10V).

\*5) Applicable at water temperature 60/40 °C, air temperature, in +18 °C.

\*6) Applicable at water temperature 40/30 °C, air temperature, in +18 °C.

\*5,6) See [www.frico.net](http://www.frico.net) for additional calculations.



## Installation and operating instructions

### General Instructions

Read these instructions carefully prior to installation and use. Keep this manual for future reference.

*The product may only be used as set out in the assembly and operating instructions. The guarantee is only valid should the product be used in the manner intended and in accordance with the instructions.*

### Application

Arden 3500 is an air curtain for recessed mounting. Recommended installation height 3,5 m. The air curtain is available without heat, with electrical heating and with water heating. Protection class: IP20.

### Operation

Air is drawn in from underneath and blown downwards shielding the door opening and minimizing heat loss. To achieve the optimum curtain effect the unit must extend the full width of the opening.

The grille for directing the outlet air is adjustable and is normally angled outwards to achieve the best protection against incoming air.

The efficiency of the air curtain depends on the air temperature, the pressure differential across the doorway and any wind load.

*NOTE! Negative pressure in the building considerably reduces the efficiency of the air curtain. The ventilation should therefore be balanced.*

### Mounting

The air curtain is installed horizontally with the outlet air grille facing downwards as close to the door as possible, concealed in the false ceiling. The only visible part of the unit is the underside which is level with the ceiling. The product must be mounted in such a way to allow future service and maintenance. The service hatch must be accessible, nothing should prevent it being fully opened.

The unit is ready for suspension with threaded bars on its outside. The threaded bars can also be fixed on the inside of the unit e.g. when mounted on a solid suspended ceiling. For the protection of wider doorways, several units can be mounted in series alongside each other. Minimum distance from outlet to floor for electrically heated units is 1800 mm.

#### *Mounting on threaded bars outside the unit*

1. The mounting brackets are fixed to the unit during transport. Loosen these, turn them around and screw into place on the unit according to fig. 1a.
2. Hang on threaded bars (M8) according to fig. 1b (accessory).
3. Adjust the height using the lower nut so that the frame is level with the ceiling. Lock using the upper nut.

#### *Mounting on threaded bars inside the unit*

1. The mounting brackets are fixed to the unit during transport. Loosen them and screw them into place inside the unit in the intended holes.
2. Hang on threaded bars (M8) according to fig. 2 (accessory). Note that the brackets are placed at different heights and therefore threaded rods should be of different lengths.
3. Adjust the height using the lower nut so that the frame is level with the ceiling. Lock using the upper nut.

### Electrical installation

The installation, which should be preceded by an isolator switch with a contact separation of at least 3 mm, should only be wired by a competent electrician and in accordance with the latest edition of IEE wiring regulations.

The air curtain has an integrated PC board which is connected to the selected external control system FC. FC must be ordered separately. The PC board is accessed via cable glands on the side or the top of the unit. FC is supplied pre-programmed. Communication- and sensor cables are connected to the PC board.

Should more than one air curtain be controlled by a single FC, an additional communication cable FCBC per unit will be required. See manual for FC.

#### *Unit without heating or with water heating*

The unit is connected via the cable gland on one side of the unit or its top. Pierce the gland with a screwdriver before entering the cable. Control supply 230V~ is routed via the motor compartment, secured with preinstalled cable ties, and connected to the PC board.

### Unit with electrical heating

The unit is connected via the cable gland on one side of the unit or its top. Pierce the gland with a screwdriver before entering the cable. Control supply 230V~ is routed via the motor compartment, secured with preinstalled cable ties, and connected to the PC board. Power supply for heating (400V3~) is routed via the motor compartment, secured with preinstalled cable ties, and connected to the terminal block in the terminal box.

The largest cable diameter for the terminal block is 16 mm<sup>2</sup>. The cable glands used must meet the protection class requirements. In the distribution board, it is to be indicated that "the air curtains can be supplied from more than one connection".

Type	Output [kW]	Voltage [V]	Minimum area* [mm <sup>2</sup> ]
Control	0	230V~	1,5
ARFEC3510E	9	400V3~	2,5
ARFEC3515E	13,5	400V3~	4
ARFEC3520E	18	400V3~	10

\*) Dimensioning of external wiring shall comply with applicable regulations and local deviations may occur.

### Start-up (E)

When the unit is used for the first time or after a long period of non-use, smoke or an odour may result from dust or dirt which has collected on the element. This is completely normal and disappears after a short time.

### Connecting the water coil (W)

The installation must be carried out by an authorised installer.

The water coil has copper tubes with aluminium fins and is suitable for connection to a closed water heating system. The heating coil must not be connected to a mains pressure water system or an open water system.

Note that the unit shall be preceded by a regulating valve, see Frico valve kit.

To access the connections the service hatch and intake grille must be opened. The water coil is connected via connections with dimensions DN20 (3/4"), inside thread, inside the unit. Holes are made during installation on the top or the side of the unit, possible places are marked with punch marks. See Fig. 5. Flexible hoses are available as accessories.



NOTE: Care must be taken when connecting the pipes. Use a pipe wrench or a similar tool to grip the air curtain connections to prevent straining of the

pipes and subsequent water leakage during connection to the water supply pipe-work.

The connections to the heating coil must be equipped with shut off valves to allow trouble-free removal.

Water coil is equipped with a drain and a vent valve.

### Adjustment of the air curtain and airflow

The direction and speed of the airflow should be adjusted considering the load on the opening. Pressure forces affect the airstream and force it inwards towards the premises (when the premises are heated and the outdoor air is cold).

The airstream should, therefore, be directed outwards to withstand the load. Generally speaking, the higher the load, the greater the angle required.

### Basic setting fan speed

The fan speed when the door is open is set using the control. Note that the airflow direction and the fan speed may need fine adjustment depending on the loading of the door.

### Filter (W)

The heat coil fin distance, in combination with the hole diameter of the intake grille, protects against dirt and blockage and makes a separate filter unnecessary.

### Service, repairs and maintenance

For all service, repair and maintenance first carry out the following:

1. Disconnect the power supply.
2. The service hatch is opened by loosening the snap fixings located on the bottom of the unit (turn 90°). See Fig. 3.
3. After service, repairs and maintenance close the service hatch and make sure that the snap fixings lock securely.

### Maintenance

Since fan motors and other components are maintenance-free, no maintenance other than cleaning is necessary. The level of cleaning can vary depending on local conditions. Undertake cleaning at least twice a year. Inlet and exhaust grilles, impeller and elements can be vacuum cleaned or wiped using a damp cloth. Use a brush when vacuuming to prevent damaging sensitive parts. Avoid the use of strong alkaline or acidic cleaning agents.

## Temperature control

Temperature control of FC maintains the exhaust temperature. Should the temperature exceed the preset value, the overheating alarm will activate. For more information see the FC manual.

## Overheating

The air curtain unit with electrical heating is equipped with an overheat protection. If it is deployed due to overheating, reset as follows:

1. Disconnect the power supply with the isolator switch.
2. Determine the cause of overheating and rectify the fault.
3. Open the service hatch. Locate the red button next to the terminal box inside the air curtain. The 2 metre unit is equipped with two red buttons placed in the centre of the unit.
4. Press the red button until a click is heard.
5. Reconnect the unit.

## Replacing the electrical coil (E)

1. Mark and disconnect the cables to the electric coil.
2. Remove the mounting screws securing the electric coil in the unit and lift out.
3. Replace faulty electrical coil.
4. Install the new electric coil in reverse order to the above.

## Replacing the water coil (W)

1. Shut off the water supply to the unit.
2. Open the vent valve.
3. Open the drain valve.
4. When the water coil is empty, disconnect its connections.
5. Remove the mounting screws securing the coil in the unit and lift out.
6. Install the new coil in reverse order to the above.

## Draining the water coil (W)

The drain valve is on the underside of the coil on the connector side. It can be accessed via the service hatch.

## Safety cut-out

All motors are equipped with an integrated safety cut-out. This will operate, stopping the air curtain should the motor temperature rise excessively or the electronics fail or overheat. The cut-out will automatically reset when the motor temperature has returned to within the

motor's operating limits. Failure or damage to electronics components may require repair or replacement of such components or the entire product.

## Fan replacement

1. Determine which of the fans is not functioning.
2. Disconnect the cables from the relevant fan.
3. Remove the screws securing the fan and lift the fan out.
4. Install the new fan as above in reverse order.

## Replacing the PC board

1. The PC board is located in the terminal box. Fig. 4
2. Mark and disconnect the cables to the PC board.
3. Unhatch the board from its PCB snap-in spacers and lift out.
4. Install the new PC board as above in reverse order.

## Troubleshooting

*If the fans are not running or do not perform properly, check the following:*

- The power supply.
- That the intake grille/filter is not dirty.
- That the motor's safety cut-out has not been deployed.
- Functions and settings of the FC control system, see the FC manual.

*If there is no heat, check the following:*

- Functions and settings of the FC control system, see the FC manual.

*For units with electrical heating, also check the following:*

- Power supply to electric heater coil; check fuses and circuit-breaker (if any).
- That the overheat protection has not been deployed.

*For units with a water coil, also check the following:*

- That the water coil is air free.
- That there is sufficient water flow and pressure.
- That incoming water is heated adequately.

If the fault cannot be rectified, please contact a qualified service technician.

### Residual current circuit breaker (E)

When the installation is protected by means of a residual current circuit breaker, which trips when the appliance is connected, this may be due to moisture in the heating element. When an appliance containing a heater element has not been used for a long period or stored in a damp environment, moisture can enter the element.

This should not be seen as a fault, but is simply rectified by connecting the appliance to the main supply via a socket without a safety cut-out so that the moisture can be eliminated from the element. The drying time can vary from a few hours to a few days. As a preventive measure, the unit should occasionally be run for a short time when it is not being used for extended periods of time.

### Packaging

Packaging materials are chosen with consideration to the environment and are therefore recyclable.

### Handling of product at end of working life

This product may contain substances necessary for the functionality of the product but potentially dangerous for the environment. The product should not be disposed of mixed with general household waste but delivered to a designated collection point for environmental recycling. Please contact the local authority for further details of your nearest designated collection point.

### Safety

- *For all installations of electrically heated products a residual current circuit breaker 300 mA for fire protection should be used.*
- *Keep the areas around the air intake and exhaust grilles free from possible obstructions!*
- *The unit must not be fully or partially covered as overheating can result in a fire risk!*
- *Lifting equipment must be used to lift the unit.*
- *This appliance can be used by children aged from 8 years and above and persons with reduced physical, sensory or mental capabilities or lack of experience and knowledge if they have been given supervision or instruction concerning use of the appliance in a safe way and understand the hazards involved. Children shall not play with the appliance. Cleaning and user maintenance shall not be made by children without supervision.*
- *Children of less than 3 years should be kept away unless continuously supervised.*
- *Children aged from 3 years and less than 8 years shall only switch on/off the appliance provided that it has been placed or installed in its intended normal operating position and they have been given supervision or instruction concerning use of the appliance in a safe way and understand the hazards involved.*
- *Children aged from 3 years and less than 8 years shall not plug in, regulate and clean the appliance or perform user maintenance.*

**CAUTION — Some parts of this product can become very hot and cause burns. Particular attention has to be given where children and vulnerable people are present.**





**Main office**

Frico AB  
Industrivägen 41  
SE-433 61 Sävedalen  
Sweden

Tel: +46 31 336 86 00

mailbox@frico.se  
www.frico.net

**For latest updated information and information  
about your local contact: [www.frico.net](http://www.frico.net)**